

IEEE 802.24.2**IoT Task Group**

Project	IEEE 802.24.2 IoT Task Group	
	Single pair Ethernet White Paper	
Date Submitted	3-March -2018	
Source	802.24.2	Chris DiMinico
Re:	White Paper Development	
Abstract	SPE White Paper	
Purpose	SPE White Paper	
Notice	This document has been prepared to assist the IEEE P802.24. It is offered as a basis for discussion and is not binding on the contributing individual(s) or organization(s). The material in this document is subject to change in form and content after further study. The contributor(s) reserve(s) the right to add, amend or withdraw material contained herein.	
Release	The contributor acknowledges and accepts that this contribution becomes the property of IEEE and may be made publicly available by P802.24.	

Single pair Ethernet

Data and Power for the Wired World

The single pair Ethernet standards are poised to provide a unifying communication protocol, a common networking infrastructure, and power for the evolving sensor technologies that will extend the cost-effectiveness and plug and-play simplicity of Ethernet to all corners of the wired world.

End point sensor technology and use cases are evolving rapidly in industrial/process, building automation, data centers as well as to support “Intelligent Building” technologies. In addition, transportation vehicles, automobiles, trucks, airplanes and next generation autonomous vehicles are requiring higher bandwidths than cannot be supported by their existing single pair technologies.

Running in parallel, to support the IEEE single pair standards, the TIA-TR42 Engineering Committee TR-42 is developing single pair telecommunications cabling infrastructure standards.

This article is an overview of the single pair standardization by the IEEE 802.3 Ethernet Working Group and by the TIA-TR42 Engineering Committee.

Definitions: The IEEE 802.3 definitions of link segment, medium dependent interface (MDI), and physical layer entity (PHY) are used throughout the article and are described below.

- The Physical Layer entity (PHY) is the portion of the Physical Layer between the Medium Dependent Interface (MDI) and Physical Medium Dependent (PMD) sublayers. The PHY contains the functions that transmit, receive, and manage the encoded signals that are impressed on and recovered from the physical medium.
- The Medium Dependent Interface (MDI) is the mechanical and electrical interface between the transmission medium and the PHY and also between the transmission medium and any associated Powered Device (PD) or Endpoint Power Sourcing Equipment (PSE).
- The Link segment is the point-to-point full-duplex medium connection between two and only two Medium Dependent Interfaces (MDIs).

In Figure 1 the Ethernet switch provides power and data through the MDI; in this case the eight-position modular jack (RJ45). The twisted-pair link segment is the medium (connectors and cables) between the MDIs. The example given is an 802.3cg topology supporting 10 Mb/s up to 1000 meters over a single pair to a variety of end points.

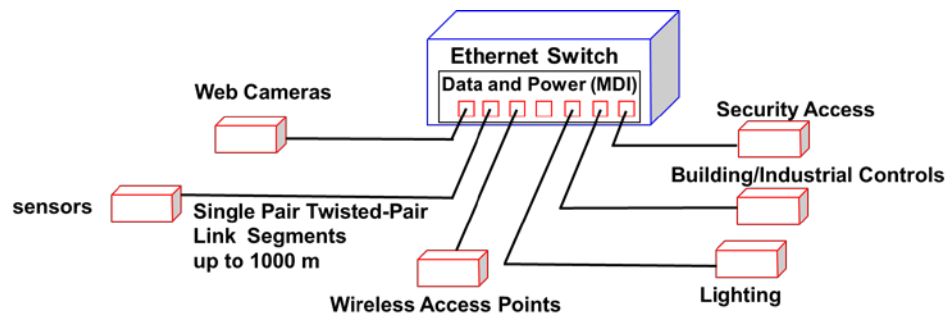

Figure 1. 802.3cg single pair Ethernet 10 Mb/s and power

IEEE 802.3 standard: IEEE Std 802.3bw-2015 100BASE-T1. 100BASE-T1 is a single pair Ethernet standard designed to support 100 Mb/s operation in automotive environments (e.g. electromagnetic compatibility, temperature) over a single balanced twisted pair. The cabling system for 100BASE-T1 consists of up to 15 m of single balanced twisted-pair cabling, with up to four in-line connectors and two mating connectors with impedance in the range of $90\ \Omega$ to $110\ \Omega$ (nominal $100\ \Omega$) to support a data rate of 100 Mb/s in each direction simultaneously.

The length of cables in the automotive wiring system example in Figure 2 can exceed 3 km with up to 1,500 cables and up to 3,000 contacts. The weight is up to 50 kg (~110 Lb). Unshielded twisted-pair for 100 Mb/s operation is preferred due to cost, weight and compactness.



Figure 2. Automotive wiring system example

100BASE-T1 Link Segment: The 100BASE-T1 link segment specifications are the minimum cabling requirements specified to support 100BASE-T1 operation. The cabling transmission parameters of the link segment include characteristic impedance, insertion loss, return loss, and delay. For single pair operation, noise coupled between link segments is considered alien crosstalk and therefore specified as power sum *alien* near-end crosstalk (PSANEXT) and power sum *alien* attenuation to crosstalk ratio far-end crosstalk (PSAACRF). Given that unshielded cabling is allowed, mode conversion loss

is specified to minimize external electromagnetic interference and alien crosstalk noise coupled between link segments. The frequencies of the specified parameters range from 1 MHz to 200 MHz.

The link segment in Figure 3 applies to 100BASE-T1 (802.3bw), 1000BASE-T1 type A (802.3bp), 802.3ch, and 10BASE-T1S (802.3cg) for the automotive link segment.

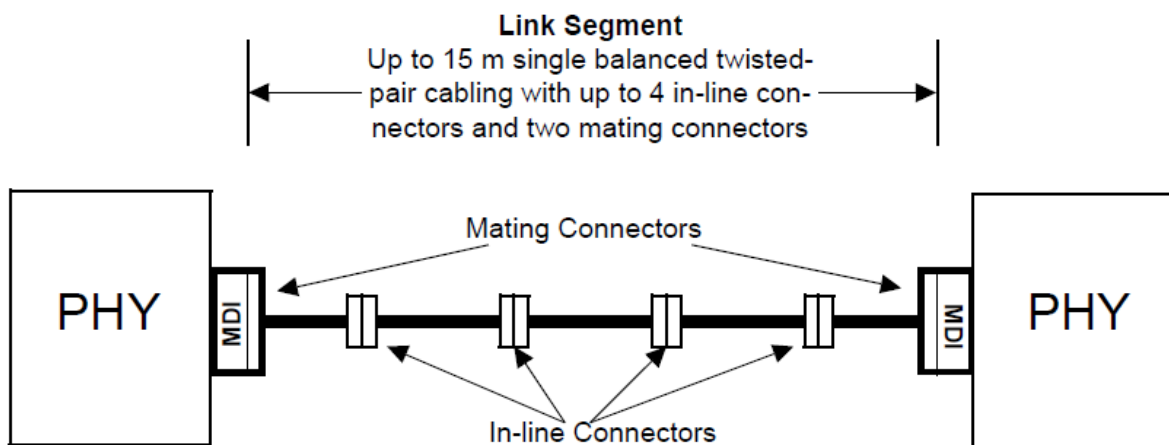

Figure 3. Example Automotive Link Segment

IEEE 802.3 standard: IEEE Std 802.3bp-2016 1000BASE-T1 PHY. 1000BASE-T1 is designed to support 1 Gb/s operation in automotive and industrial environments (e.g. electromagnetic compatibility, temperature). 1000BASE-T1 is designed to operate over a single twisted-pair copper cable supporting an effective data rate of 1 Gb/s in each direction simultaneously.

Two link segments are specified:

a) A link segment optimized for use in automotive applications that supports up to four in-line connectors using a single twisted-pair copper cable for up to at least 15 m. This link segment is referred to as link segment type A and is illustrated in Figure 1.

1000BASE-T1 type A Link Segment: The 1000BASE-T1 link segment parameters are the minimum cabling requirements specified to support 1000BASE-T1 operation. The cabling transmission parameters of the link segment include characteristic impedance, insertion loss, return loss, and delay. For single pair operation, noise coupled between link segments is considered alien crosstalk and therefore specified as power sum alien near-end crosstalk (PSANEXT) and power sum alien attenuation to crosstalk ratio far-end crosstalk (PSAACRF). Given that unshielded cabling is allowed, mode conversion loss is specified to minimize external electromagnetic interference and alien crosstalk noise coupled between link segments. The frequencies of the specified parameters range from 1 MHz to 600 MHz.

b) An optional link segment supporting up to four in-line connectors using a single twisted-pair copper cable for up to at least 40 m to support applications requiring additional physical reach, such as industrial and automation controls and transportation (aircraft, railway, bus and heavy trucks). This link segment is referred to as link segment type B illustrated in Figure 4.

1000BASE-T1 type B Link Segment: The 1000BASE-T1 link segment parameters are the minimum cabling requirements specified to support 1000BASE-T1 operation. The cabling transmission parameters of the link segment include characteristic impedance, insertion loss, return loss, and delay. For single pair operation, noise coupled between link segments is considered alien crosstalk and therefore specified as power sum alien near-end crosstalk (PSANEXT) and power sum alien attenuation to crosstalk ratio far-end crosstalk (PSAACRF). As unshielded cabling is allowed, mode conversion loss is specified to minimize external electromagnetic interference and alien crosstalk noise coupled between link segments. The frequencies of the specified parameters range from 1 MHz to 600 MHz.

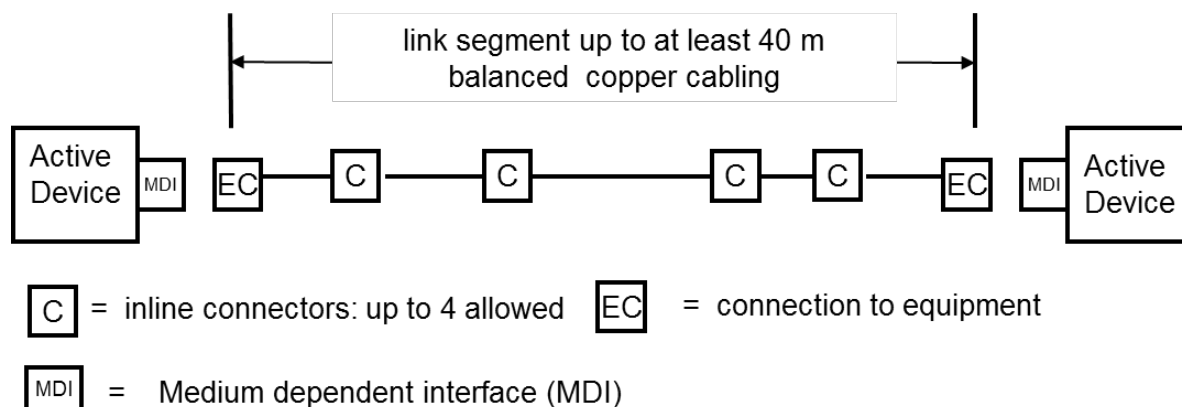

Figure 4. Example 1000BASE-T1 Link Segment type B

IEEE 802.3 draft standard: IEEE P802.3ch Multi-Gig Automotive Ethernet PHY Task Force.

The objectives of the P802.3ch related to the single pair link segment characteristics (cabling) and associated data rates are given below. The 802.3ch link segment topology is illustrated in Figure 1. Note that a draft standard is subject to change prior to publication.

The 802.3ch specification is to:

- Define the performance characteristics of an automotive link segment and an electrical PHY to support 2.5 Gb/s point-to-point operation over this link segment supporting up to four inline connectors for at least 15m on at least one type of automotive cabling (e.g., UTP, STQ, STP, SPP, Coax, or Twinax).

- Define the performance characteristics of an automotive link segment and an electrical PHY to support 5 Gb/s point-to-point operation over this link segment supporting up to four inline connectors for at least 15m on at least one type of automotive cabling.
- Define the performance characteristics of an automotive link segment and an electrical PHY to support 10 Gb/s point-to-point operation over this link segment supporting up to four inline connectors for at least 15m on at least one type of automotive cabling.

The IEEE P802.3ch Link Segment is in development by the Task Group.

IEEE 802.3 draft standard: IEEE P802.3cg 10 Mb/s Single Twisted Pair Ethernet Task Force.

The objectives of the P802.3cg related to the single pair link segment characteristics (cabling), associated data rates, and optional power techniques are given below. Note that a draft standard is subject to change prior to publication.

- Support 10 Mb/s operation in automotive environments (e.g. EMC, temperature) over single balanced twisted-pair cabling.
- Support 10 Mb/s operation in industrial environments (e.g. EMC, temperature) over single balanced twisted-pair cabling.
- Do not preclude working within an Intrinsically Safe device and system as defined in IEC 60079.
- Define the performance characteristics of a link segment and a PHY to support operation over this link segment with single twisted pair supporting up to four inline connectors using balanced cabling for up to at least 15 m reach
- Define the performance characteristics of a link segment and a PHY to support point-to-point operation over this link segment with single twisted pair supporting up to 10 inline connectors using balanced cabling for up to at least 1 km reach
- Specify one or more optional power distribution techniques for use over the 10 Mb/s single balanced twisted-pair link segments, in conjunction with 10 Mb/s single balanced twisted-pair PHYs, in the automotive and industrial environment

Two link segments are specified:

a) 10BASE-T1S link segment for the automotive environment with single twisted pair supporting up to four inline connectors using balanced cabling for up to at least 15 m reach. The 10BASE-T1S link segment topology is illustrated in Figure 1.

10BASE-T1S link segment: The 10BASE-T1S link segment parameters are the minimum cabling requirements specified to support 10BASE-T1S operation. As of December 2017, the cabling transmission parameters of the link segment include insertion loss, return loss, and mode conversion. Given that unshielded cabling is allowed, mode conversion loss is specified to minimize external electromagnetic interference and alien crosstalk noise coupled between link segments. The frequencies of the specified parameters range from 300 KHz to 200 MHz.

b) 10BASE-T1L link segment for the industrial environments with single twisted pair supporting up to 10 inline connectors using balanced cabling for up to at least 1 km reach. The 10BASE-T1L link segment topology is illustrated in Figure 5.

10BASE-T1L link segment: The 1000BASE-T1L link segment specifications are the minimum cabling requirements specified to support 100BASE-T1L operation. As of December 2017, the cabling transmission parameters of the link segment include insertion loss and return loss. For single pair operation, noise coupled between link segments is considered alien crosstalk and therefore specified as power sum alien near-end crosstalk (PSANEXT) and power sum alien far-end crosstalk (PSAFEXT). The frequencies of the specified parameters range from 100 KHz to 20 MHz.

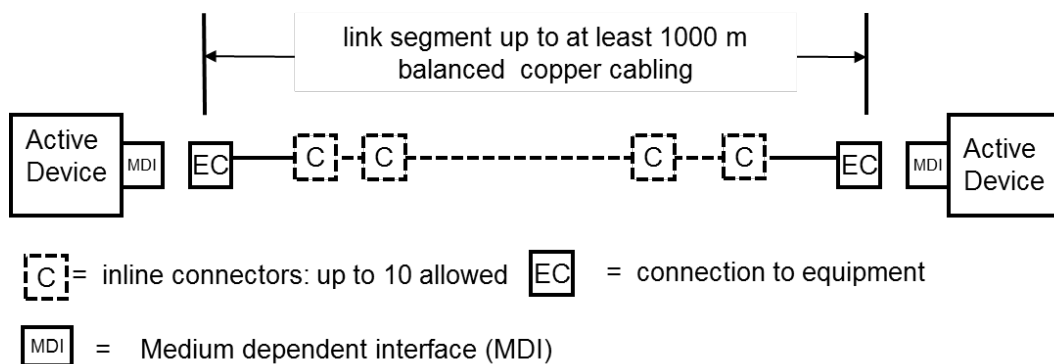

Figure 5. Example 10BASE-T1L Link Segment

Optional Power Distribution: The 802.3cg objective to specify one or more optional power distribution techniques for use over the 10 Mb/s single balanced twisted-pair link segments is addressed in Annex 200A of the draft standard. The Annex defines the functional and electrical characteristics of the PD and PSE in the automotive and industrial environment.

Two powering topologies are recognized in the Annex “point-to-point” and “powered trunk cable”.

The point-to-point powering topology is illustrated in Figure 6; single pair Ethernet powered devices, e.g., sensors and actuators connected to single-pair point-to-point link sections.

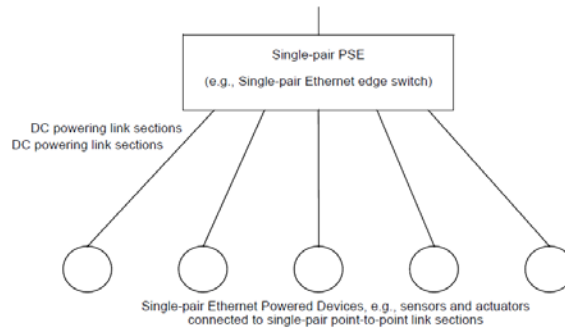

Figure 6. Point-to-point powering topology

The classification of the power delivered to the PDs are given in Table 2. The minimum continuous power that the PSE shall be capable of supplying (Ppd) for the 1000 m point-to-point link segment is given for each class. The 59 ohm loop resistance is derived from 1000 meters of 18 AWG stranded conductor cable and the 10 in-line connectors and the 39 ohm loop resistance is derived from 1000 meters of 14 AWG stranded conductor cable and 10 in-line connectors.

Class	Vpse, min (V)	Ipi, max (A)	Rloop (60C) (ohm)	Ppd(min) (1000 m) (W)
1	20	.102	59	1.4
2	20	.155	39	2.2
3	50	.255	59	8.9
4	50	.388	39	13.6

Table 2. Point-to-point class power requirements

The “powered trunk cable” powering topology is illustrated in Figure 7. The classification of power is under study in the Task Group.

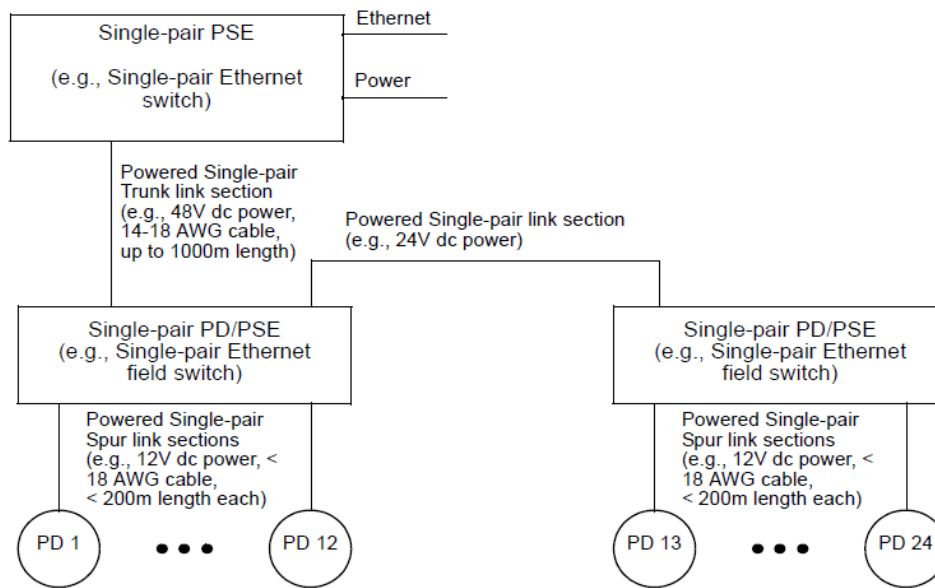

Figure 7. “powered trunk cable” topology

IEEE 802.3 standard: IEEE Std 802.3bu-2016 1-Pair Power over Data Lines (PoDL). PoDL specifies a power distribution technique for use over a single twisted pair link segment and allows for power operation even if the data is not present. It supports voltage and current levels for the automotive, transportation, and industrial control industries. The PoDL system block diagram is illustrated in Figure 8. PDs and PSE systems are defined as compatible at their respective Power Interfaces (PIs).

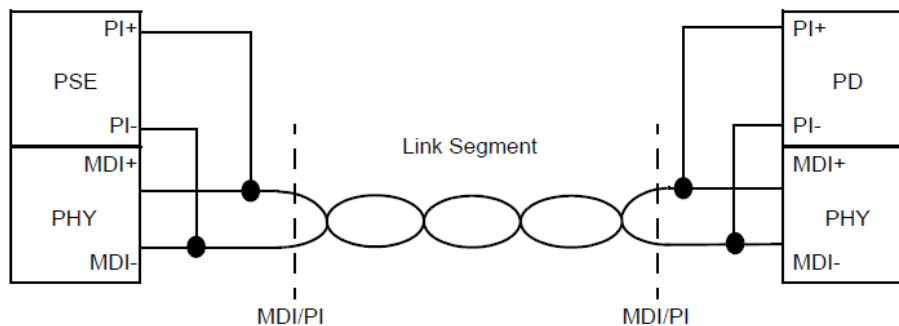

Figure 8. PoDL system block diagram

PoDL powers supply equipment (PSE) and powered devices (PD) are categorized by their classes. These classes and the relevant electrical specifications are given in Table 2. The power delivered to the PD is P_{pd} in watts.

Class	12 V unregulated PSE		12 V regulated PSE		24 V unregulated PSE		24 V regulated PSE		48 V regulated PSE	
	0	1	2	3	4	5	6	7	8	9
Vpse(max) V	18	18	18	18	36	36	36	36	60	60
Vpse(min) V	5.6	5.77	14.4	14.4	11.7	11.7	26	26	48	48
Ipl(max) mA	101	227	249	471	97	339	215	461	735	1360
Pclass(min) W	0.566	1.31	3.59	6.79	1.14	3.97	5.59	12	35.3	65.3
Ppd W	0.5	1	3	5	1	3	5	10	30	50

Table 2. Class power requirements matrix for PSE, PI, and PD

As an example PoDL use case, In Figure 9 an interconnection configuration is illustrated where PSE in the telecommunication room is interconnected to the horizontal cabling patch panel utilizing an equipment cable. The interconnection enables PSE cabling reconfigurations at the patch panel using equipment cords. In both configurations the powered device (PD) on the remote end of the horizontal cabling is connected to a telecommunications outlet via a work area cable.

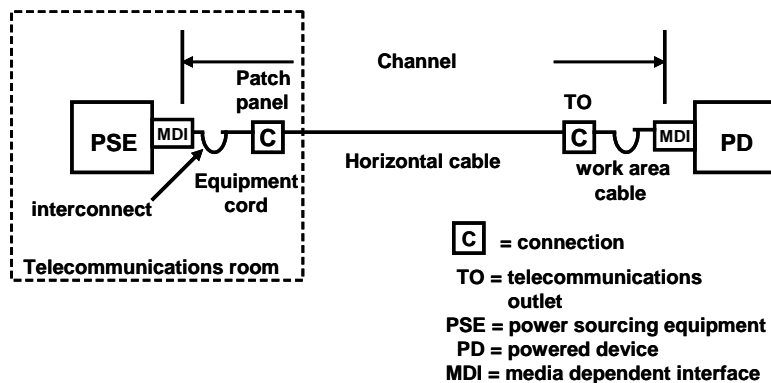

Figure 9. Powered Interconnect Configuration

Definitions: ANSI/TIA-568-C.0 provides information in Annex F for the environmental classifications that are used in this article and are described below.

MICE is an environmental classifications for the purpose of describing areas in which cabling is placed. The specifications of MICE include: M - mechanical; I - ingress; C - climatic; and, E - electromagnetic. MICE 1 (M₁I₁C₁E₁) generally relates to environmentally controlled areas such as commercial building offices, MICE 2 (M₂I₂C₂E₂) generally relates to a light industrial environment and MICE 3 (M₃I₃C₃E₃) generally relates to an industrial environment. The classification for areas with mixed environments may be described by including the classification level for each variable as a subscript (e.g., M₁I₂C₃E₁). If a cabling system component crosses an environmental boundary, the component or mitigation technique should be selected to be compatible with the worst case environment to which it is exposed.

TIA-TR42 single pair projects in TR42.1:

- ANSI/TIA-862-B-2 intelligent buildings

Amendment to add single twisted-pair use cases, topology, and architecture to ANSI/TIA-862-B providing guidelines in buildings where 1-pair cabling can be deployed in addition to the 4-pair cabling used for IBS applications. The standard will include installation requirements and additional guidelines for transitioning 2 4-pair to 1-pair cabling including sheath sharing. The standard will also provide single twisted-pair cabling guidelines for emerging IOT and M2M applications that will require higher density, reduced size, and greater flexibility to serve these IOT devices.

- ANSI/TIA-568.0-D-2 generic cabling

The scope of single pair TR42.1 generic cabling is under consideration in TR42.1. Presentations on the scope propose that TIA TR42.1 develop a standard to enable the migration of 100BASE-T1, 1000BASE-T1, 10BASE-T1 and 10GBASE-T1 into buildings by standardizing a generic single pair cabling architecture(s).

TIA-TR42 single pair project in TR42.7:

- ANSI/TIA-568.5 - Single pair balanced twisted-pair telecommunications cabling and components standard

A single balanced twisted-pair cabling and components standard to provide specifications for cables, connectors, cords, links and channels using 1-pair connectivity in non-industrial premises telecommunications networks. The standard will focus on MICE1 environments and will include cabling and component performance requirements and test procedures, reliability requirements and test procedures, as well as guidelines for adaptations to four pair cabling.

- The standard will include field tester specifications to verify the performance of installed single pair cabling. The cabling transmission performance requirements apply from 100 KHz up to 600 MHz.
- 100 meter and 15 meter channel configurations are supported. The 100 m test configuration is consistent with TIA-568 four pair cabling topologies. The 15 meter topology enables support for 100BASE-T1, 1000BASE-T1, 10BASE-T1 and 10GBASE-T1 technologies specified to operate over 15 meters of cabling.

TIA-TR42 single pair project in TR42.9:

- ANSI/TIA-1005-A - Single pair balanced twisted-pair telecommunications cabling and components standard

A single twisted-pair cabling and components standard to provide specifications for cables, connectors, cords, links and channels using 1-pair connectivity in industrial premises telecommunications networks. The standard will focus on MICE2 and MICE3 environments and will include cabling and component performance requirements and test procedures, reliability requirements and test procedures, as well as guidelines for adaptations to four pair cabling.

Summary: We are in a brave new world of converged data and power. The single pair Ethernet and TR42 standards are poised to enable a new class of low power Ethernet devices that will facilitate networking and powering the billions of end point sensors forecasted by the year 2022.