

IEEE P802.15

Wireless Personal Area Networks

Project	IEEE P802.15 Working Group for Wireless Personal Area Networks (WPANs)		
Title	Preliminary document for TG4p		
Date Submitted	21 March 2013		
Source	[Meng-Chang Doong, Yale Lee, Hamid Movahedi] [Lilee Systems] [2905 Stender Way, Suite 78 Santa Clara, CA 95054]	Voice: [] Fax: [] E-mail: [mdoong@lileesystems.com yjlee@lileesystems.com hmovahedi@lileesystems.com]	
Re:			
Abstract	This document combines the work done thus far by TG4p.		
Purpose	This document is the first step in preparing a draft for letter ballot.		
Notice	This document has been prepared to assist the IEEE P802.15. It is offered as a basis for discussion and is not binding on the contributing individual(s) or organization(s). The material in this document is subject to change in form and content after further study. The contributor(s) reserve(s) the right to add, amend or withdraw material contained herein.		
Release	The contributor acknowledges and accepts that this contribution becomes the property of IEEE and may be made publicly available by P802.15.		

IEEE Standard for Local and metropolitan area networks—

Part 15.4: Low-Rate Wireless Personal Area Networks (WPANs)

Amendment X: Positive Train Control (PTC) System Physical Layer

NOTE—The editing instructions contained in this amendment define how to merge the material contained therein into the existing base standard and its amendments to form the comprehensive standard.

The editing instructions are shown in *bold italic*. Four editing instructions are used: change, delete, insert, and replace. *Change* is used to make corrections in existing text or tables. The editing instruction specifies the location of the change and describes what is being changed by using ~~striethrough~~ (to remove old material) and underscore (to add new material). *Delete* removes existing material. *Insert* adds new material without disturbing the existing material. Deletions and insertions may require renumbering. If so, renumbering instructions are given in the editing instruction. *Replace* is used to make changes in figures or equations by removing the existing figure or equation and replacing it with a new one. Editing instructions, change markings, and this NOTE will not be carried over into future editions because the changes will be incorporated into the base standard.

1
2
3
4
5
6
7
8
9
10
11
12
13
14
15
16
17
18
19
20
21
22
23
24
25
26
27
28
29
30
31
32
33
34
35
36
37
38
39
40
41
42
43
44
45
46
47
48
49
50
51
52
53
54

1
2
3
4
5
6
7
8
9
10
11
12
13
14
15
16
17
18
19
20
21
22
23
24
25
26
27
28
29
30
31
32
33
34
35
36
37
38
39
40
41
42
43
44
45
46
47
48
49
50
51
52
53
54

2. Normative references

Insert the following new reference alphabetically into Clause 2:

U.S. Code of Federal Regulations, Title 47: Telecommunication, Part 90—Private Land Mobile Radio Services, Subpart Y—Regulations Governing Licensing and Use of Frequencies in the 4940–4990 MHz Band.

1
2
3
4
5
6
7
8
9
10
11
12
13
14
15
16
17
18
19
20
21
22
23
24
25
26
27
28
29
30
31
32
33
34
35
36
37
38
39
40
41
42
43
44
45
46
47
48
49
50
51
52
53
54

1
2
3
4
5
6
7
8
9
10
11
12
13
14
15
16
17
18
19
20
21
22
23
24
25
26
27
28
29
30
31
32
33
34
35
36
37
38
39
40
41
42
43
44
45
46
47
48
49
50
51
52
53
54

3. Definitions, acronyms, and abbreviations

3.1 Definitions

Change the following definition as indicated:

BT: ~~s~~Shaping parameter for filtered FSK ~~or GMSK~~ modulation, where B is the 3 dB bandwidth of the shaping filter, and T is the FSK ~~or GMSK~~ symbol period.

Insert the following definition alphabetically into 3.1:

positive train control (PTC): A system of functional requirements for monitoring and controlling train movements to provide increased safety defined by U.S. federal law in 49 CFR 236.1005.(a).

3.2 Acronyms and abbreviations

Insert the following acronyms alphabetically into 3.2:

C4FM	continuous four-level frequency modulation
DPSK	differential phase-shift keying
GMSK	Gaussian-filtered minimum shift keying
LMR	land mobile radio
Pi/4 DQPSK	Pi/4 differential quadrature phase-shift keying
PTC	positive train control
QPSK	quadrature phase-shift keying
RCC	rail communications and control

1
2
3
4
5
6
7
8
9
10
11
12
13
14
15
16
17
18
19
20
21
22
23
24
25
26
27
28
29
30
31
32
33
34
35
36
37
38
39
40
41
42
43
44
45
46
47
48
49
50
51
52
53
54

1
2
3
4
5
6
7
8
9
10
11
12
13
14
15
16
17
18
19
20
21
22
23
24
25
26
27
28
29
30
31
32
33
34
35
36
37
38
39
40
41
42
43
44
45
46
47
48
49
50
51
52
53
54

4. General description

Insert the following new subclause (4.1b) after 4.1a:

4.1b Introduction to positive train control (PTC)

PTC refers to a system that meets the functional performance requirements for monitoring and controlling train movements to provide increased safety as defined by federal law in 49 CFR 236.1005.(a).

PTC systems are integrated command, control, communications, and information systems for controlling train movements with safety, security, precision, and efficiency. PTC systems will improve railroad safety by significantly reducing the probability of collisions between trains, casualties to roadway workers and damage to their equipment, and over speed accidents. The National Transportation Safety Board has named PTC as one of its “most-wanted” initiatives for national transportation safety.

PTC systems are comprised of digital data link communications networks, continuous and accurate positioning systems such as National Differential GPS, on-board computers with digitized maps on locomotives and maintenance-of-way equipment, in-cab displays, throttle-brake interfaces on locomotives, wayside interface units at switches and wayside detectors, and control center computers and displays. PTC systems may also interface with tactical and strategic traffic planners, work order reporting systems, and locomotive health reporting systems. PTC systems issue movement authorities to train and maintenance-of-way crews, track the location of the trains and maintenance-of-way vehicles, have the ability to automatically enforce movement authorities, and continually update operating data systems with information on the location of trains, locomotives, cars, and crews. The remote intervention capability of PTC will permit the control center to stop a train should the locomotive crew be incapacitated. In addition to providing a greater level of safety and security, PTC systems also enable a railroad to run scheduled operations and provide improved running time, greater running time reliability, higher asset utilization, and greater track capacity. They will assist railroads in measuring and managing costs and in improving energy efficiency.

The United States Congress enacted a law called the Rail Safety Improvement Act of 2008, in order to improve rail safety. The law mandates the use of PTC for most rail and rail transit entities. PTC has four primary components:

- Equipment deployed on the locomotive/train
- Equipment deployed trackside
- Network access points deployed at or near trackside that are connected to systems operating at a remotely located control center
- A bi-directional wireless data link that connects all these elements

In the United States, there has been a plurality of wireless communication methods used since the 1970s for rail and rail transit data communications. However, while the need for mobile wireless data communications has continued to expand, there had been little effort, until now, to establish a broadly applicable open standard. This standard provides a simple, low-data rate, wireless data packet protocol suitable for machine-to-machine applications, such as PTC.

A number of radio frequency bands currently used or planned for rail and rail transit communications are included in this standard. Also included are modulation modes and error-correction techniques that enhance functionality for low-data rate vehicular communications.

1
2
3
4
5
6
7
8
9
10
11
12
13
14
15
16
17
18
19
20
21
22
23
24
25
26
27
28
29
30
31
32
33
34
35
36
37
38
39
40
41
42
43
44
45
46
47
48
49
50
51
52
53
54

5. MAC protocol

5.1 MAC functional description

5.1.1 Channel access

5.1.1.6 LLDN Superframe structure

Insert the following new subclause (5.1.1.6.7) following 5.1.1.6.6:

5.1.1.6.7 LLDN usage by an RCC device

An RCC device should support LLDN mode with an additional shared group time slot allocated for broadcasting messages from one device to all devices within range, using the slotted contention-based access method specified in 5.1.1.4.4.

If any device loses timing synchronization with the coordinator, that device will implement the CSMA mode described in 5.1.1.4, in order to allow the broadcast messages to be received.

An RCC device running in LLDN mode should always use enhanced beacon frames, in order to allow different modulation schemes to be assigned to different slot owners.

The modulation scheme of the enhanced beacon frame and the management time slots should be set by a higher layer.

The RCC Capabilities information element (IE) advertises all frequency bands, modulation schemes, and data rates supported by the coordinator, as described in 5.2.4.28a.

Devices may optionally request to use any modulation scheme advertised by the coordinator in the enhanced beacon frame.

5.1.8 Ranging

Insert the following new subclause after 5.1.8.4:

<Editor's note: Subclause 5.1.8.5 is being added to the baseline standard by TG4m. The information is provided here as a reference for the reader. This text will be removed from this draft once TG4m is published.>

5.1.8.5 The ranging exchange with information elements

In an RDEV that supports IEs, the range exchange may be performed by the MAC as part of the data/acknowledgment process.

This process is initiated upon receipt of an MCPS-DATA.request with the Ranging parameter set to a supported ranging mode, and the UseRangingIE parameter set to TRUE. The MAC sublayer will generate a Ranging Request IE, as described in 5.2.4.34.1, and include it in the data or multipurpose frame sent. The Ranging Method field shall be set according to the RangingMethod parameter of the request. The Ranging Message Sequence Number field shall be incremented with each MCPS-DATA.request having ranging enabled. The AR field of the FCF shall be set to request an acknowledgment. The Timestamp parameter will be included in the generated MCPS-DATA.confirm primitive.

When a data or multipurpose frame containing a Ranging Request IE is received by an RDEV that supports IEs, the receive Timestamp is captured and a Ranging Response IE, described in 5.2.4.34.2, is included in the acknowledgment. The Response TX Timestamp field of the Ranging Response IE is set to the local time

reference when the acknowledgment is transmitted. If the Ranging Method field of the received Ranging Request IE indicates a two-way ranging request, the Request RX Timestamp field is set to the timestamp captured when the packet containing the request was received.

Upon receipt of the acknowledgment by the originating device, the timestamp parameters of the MCPS-DATA.confirm primitive are set according to the contents of the Ranging Response IE.

Insert the following new subclause (5.1.8.6) after 5.1.8.5:

5.1.8.6 Support for ranging in an RCC device

An RCC device should support the Ranging Request IE and the Ranging Response IE, as specified in 5.2.4.34.

The PIB attribute *macEnhAckWaitDuration* should be set based on the ranging results using the formula:

$$macEnhAckWaitDuration = aUnitBackoffPeriod + aTurnaroundTime + phySHRDuration + \text{ceiling}(6 \times phySymbolsPerOctet) + 2 \times \left(\frac{d}{3 \times 10^8 \times 10^6} \right)$$

where *d* is the estimated range in meters.

5.1.11 LE transmission, reception and acknowledgment

5.1.11.1 Coordinated sampled listening (CSL)

5.1.11.1.4 Unicast transmission

Change step f) in paragraph three as indicated:

- f) Wait for ~~up to~~ at least *macEnhAckWaitDuration* (defined in Table 52j) ~~symbol time~~ for the enhanced acknowledgment frame if the Acknowledge Request field in the payload frame is set to one.

5.2 MAC frame formats

5.2.4 Information Element

5.2.4.2 Header information elements

Insert the following new rows at the end of Table 4b as indicated:

Table 4b—Element IDs, Header IEs

Element ID	Content length	Name	Description
<editor’s note: this value will be assigned at sponsor ballot>		RCC Capabilities	As defined in 5.2.4.28a.

5.2.4.5 MLME Information Elements

Insert the following new rows at the end of Table 4d as indicated:

Table 4d—Sub-ID allocation for short form

Sub-ID value	Content length	Name	Description
<editor's note: this value will be assigned at sponsor ballot>		RCC PHY Operating Mode	Description of the operating mode parameters for the RCC PHY, as defined in 5.2.4.29.3.
<editor's note: this value will be assigned at sponsor ballot>		Ranging Request IE	Description of the request for device ranging, as defined in 5.2.4.34.1.
<editor's note: this value will be assigned at sponsor ballot>		Ranging Response IE	Description of the response for device ranging, as defined in 5.2.4.34.2.

5.2.4.28a RCC Capabilities IE

The following IE declares the RCC capabilities supported by a device. The presence of this IE in a transmitted frame indicates that the coordinator supports an RCC PHY. The IE content shall be as shown in Figure 48aae.

Octets: 3	2	2
PHY Frequency Bands Supported	RCC PHY and Modulation Supported	LMR PHY DSSS DPSK Modulation Supported Feature

Figure 48aae —Format of the RCC Capabilities IE

Table 4wa contains the RCC Frequency Bands Supported field encoding, Table 4wb contains the RCC PHY and Modulation Supported field encoding, and Table 4wc contains the LMR PHY DSSS DPSK Modulation Supported Feature field encoding.

Table 4wa—RCC PHY Frequency Bands Supported field encoding

Bit number	Description
0	Band 161 MHz supported
1	Band 216 MHz supported
2	Band 217 MHz supported
3	Band 220 MHz supported
4	Band 450 MHz supported
5	Band 770 MHz supported

1
2
3
4
5
6
7
8
9
10
11
12
13
14
15
16
17
18
19
20
21
22
23
24
25
26
27
28
29
30
31
32
33
34
35
36
37
38
39
40
41
42
43
44
45
46
47
48
49
50
51
52
53
54

Table 4wa—RCC PHY Frequency Bands Supported field encoding

Bit number	Description
6	Band 800 MHz supported
7	Band 806 MHz supported
8	Band 896 MHz supported
9	Band 901 MHz supported
10	Band 915 MHz supported
11	Band 928 MHz supported
12	Band 4965 MHz supported
13	Band 5300 MHz supported
14	Band 5600 MHz supported
15	Band 5700 MHz supported
16	Band 5800 MHz supported
17–23	Reserved

Table 4wb—RCC PHY and Modulation Supported field encoding

Bit number	Description
0	LMR PHY GMSK 9.6 kbps supported
1	LMR PHY GMSK 19.2 kbps supported
2	LMR PHY C4FM 9.6 kbps supported
3	LMR PHY C4FM 19.2 kbps supported
4	LMR PHY C4FM 38.4 kbps supported
5	LMR PHY QPSK 16 kbps supported
6	LMR PHY QPSK 32 kbps supported
7	LMR PHY Pi/4 DQPSK 16 kbps supported
8	LMR PHY Pi/4 DQPSK 32 kbps supported
9	LMR PHY Pi/4 DQPSK 36 kbps supported
10	LMR PHY DSSS DPSK supported
11	DSSS BPSK PHY supported
12–15	Reserved

5.2.4.29 Operating Mode Description IEs

5.2.4.29.3 RCC PHY Operating Mode Description IE

The RCC PHY Operating Mode Description IE content shall be encoded as shown in Table 4z.

Table 4wc—RCC LMR PHY DSSS DPSK Modulation Supported Feature field encoding

Bit number	Description
0	300 kcps chip rate supported
1	600 kcps chip rate supported
2	800 kcps chip rate supported
3	1 Mcps chip rate supported
4	1.6 Mcps chip rate supported
5	2 Mcps chip rate supported
6	3 Mcps chip rate supported
7	4 Mcps chip rate supported
8	11-chip spreading sequence supported
9	15-chip spreading sequence supported
10	20-chip spreading sequence supported
11	40-chip spreading sequence supported
12	DSSS DBPSK supported
13	DSSS DQPSK supported
14–15	Reserved

Table 4z—Operating Mode Information field encoding for RCC PHY

Bit number	Description
0–3	The operating band selected. The bands are defined as the integers greater than zero that correspond to the bit numbers given in Table 4wa.
4–16	The channel number, as defined in Table 68m.
17–20	PHY and modulation selection 0 = LMR PHY GMSK 9.6 kbps 1 = LMR PHY GMSK 19.2 kbps 2 = LMR PHY C4FM 9.6 kbps 3 = LMR PHY C4FM 19.2 kbps 4 = LMR PHY C4FM 38.4 kbps 5 = LMR PHY QPSK 16 kbps 6 = LMR PHY QPSK 32 kbps 7 = LMR PHY Pi/4 DQPSK 16 bps 8 = LMR PHY Pi/4 DQPSK 32 bps 9 = LMR PHY Pi/4 DQPSK 36 bps 10 = LMR PHY DSSS DPSK 11 = DSSS BPSK PHY 12–15 = Reserved

1
2
3
4
5
6
7
8
9
10
11
12
13
14
15
16
17
18
19
20
21
22
23
24
25
26
27
28
29
30
31
32
33
34
35
36
37
38
39
40
41
42
43
44
45
46
47
48
49
50
51
52
53
54

Table 4z—Operating Mode Information field encoding for RCC PHY

Bit number	Description
21–23	Chip rate selection for LMR PHY DSSS DPSK 0 = 300 kcps 1 = 600 kcps 2 = 800 kcps 3 = 1 Mcps 4 = 1.6 Mcps 5 = 2 Mcps 6 = 3 Mcps 7 = 4 Mcps
24–26	Spreading sequence selection for LMR PHY DSSS DPSK 0 = 11-chip 1 = 15-chip 2 = 20-chip 3 = 40-chip 4–7 = Reserved
21–31	Reserved

<Editor's note: Subclauses 5.2.4.34–5.2.4.34.2 are being added to the baseline standard by TG4m. The information is provided here as a reference for the reader. This text will be removed from this draft once TG4m is published.>

5.2.4.34 Ranging Support IEs

5.2.4.34.1 Ranging Request IE

The Ranging Request IE is used by a device to initiate the transfer of ranging measurements between devices. In a ranging capable device, the presence of a Ranging Request IE signals the receiving MAC entity that the receive timestamp should be captured and returned to the requesting device. This IE is used in the ranging exchange described in 5.1.8.5.

The Ranging Request IE content is encoded as shown in Figure 48nab.

Octets: 1	
Bit: 0	1–7
Ranging Method	Ranging Message Sequence Number

Figure 48nab— Ranging Request IE content

The Ranging Method field shall be set to zero to indicate one-way ranging and set to one to indicate two-way ranging. The Ranging Message Sequence Number field shall be set as described in 5.1.8.5.

5.2.4.34.2 Ranging Response IE

The Ranging Response IE is encoded as shown in Figure 48nac.

The Ranging Method field shall be set to zero to indicate one-way ranging and set to one to indicate two-way ranging. The Ranging Message Sequence Number field shall be set as described in 5.1.8.5.

Octets: 1		0/4	4
Bit: 0	1–7		
Ranging Method	Ranging Message Sequence Number	Request RX Timestamp	Response TX Timestamp

Figure 48nac— Ranging Response IE content

The Request RX Timestamp field shall be present when the ranging method field is set to two-way ranging and shall contain the time, in the time reference of the responding device, that the request was received. The field shall be omitted when the ranging method field is set to one-way ranging.

The Response TX Timestamp field shall be set to the TX time, in the time reference of the responding device, when the response packet is transmitted.

1
2
3
4
5
6
7
8
9
10
11
12
13
14
15
16
17
18
19
20
21
22
23
24
25
26
27
28
29
30
31
32
33
34
35
36
37
38
39
40
41
42
43
44
45
46
47
48
49
50
51
52
53
54

1
2
3
4
5
6
7
8
9
10
11
12
13
14
15
16
17
18
19
20
21
22
23
24
25
26
27
28
29
30
31
32
33
34
35
36
37
38
39
40
41
42
43
44
45
46
47
48
49
50
51
52
53
54

8. General PHY requirements

8.1 General requirements and definitions

Insert the following items at the end of the second bulleted list in 8.1:

- **RCC LMR PHY:** a PHY operating at multiple over-the-air data rates in support of land mobile radio (LMR) for use in rail communications and control (RCC) applications, as defined in 21.1, that supports the following five modulation schemes: Gaussian minimum shift keying (GMSK), continuous four-level frequency modulation (C4FM), quadrature phase-shift keying (QPSK), pi/4 differential quadrature phase-shift keying (Pi/4 DQPSK), and direct sequence spread spectrum (DSSS) employing differential phase-shift keying (DPSK).
- **RCC DSSS BPSK:** a DSSS binary phase-shift keying (BPSK) PHY operating at multiple over-the-air data rates for use in RCC applications, as defined in 21.2.

8.1.1 Operating frequency range

Change the first paragraph of 8.1.1 as indicated, and insert the new table (Table 66c):

<Editor's note: the following paragraph is in the process of being modified by 15.4k. The text shown below is a modification to the 4k text.>

A compliant device shall operate in one or several frequency bands summarized in Table 66, Table 66a, ~~and Table 66b,~~ and Table 66c. Table 66a shows frequency bands for devices supporting the LECIM DSSS PHY, and Table 66b shows frequency bands for devices supporting the LECIM FSK PHY. Table 66c shows frequency bands for devices supporting the RCC PHY.

Table 66c—Frequency bands and data rates for RCC PHY

Band identifier	Frequency range (MHz)	Modulation and bit rate
161	160.170–161.580	LMR PHY GMSK: 9.6/19.2 kbps LMR PHY C4FM: 9.6/19.2/38.4 kbps LMR PHY QPSK: 16/32 kbps LMR PHY Pi/4 DQPSK: 16/32/36 kbps
216	216–217	
217	217–220	
220	220–222	
450	450–470	
770	769–775	
800	799–805	
806	806–821 851–866	
896	896–901 935–940	
901	901–902	

Table 66c—Frequency bands and data rates for RCC PHY

Band identifier	Frequency range (MHz)	Modulation and bit rate
915	902–928	LMR PHY GMSK: 9.6/19.2 kbps LMR PHY C4FM: 9.6/19.2/38.4 kbps LMR PHY QPSK: 16/32 kbps LMR PHY Pi/4 DQPSK: 16/32/36 kbps LMR PHY DSSS DPSK DSSS BPSK PHY
928	928–960	LMR PHY GMSK: 9.6/19.2 kbps LMR PHY C4FM: 9.6/19.2/38.4 kbps LMR PHY QPSK: 16/32 kbps LMR PHY Pi/4 DQPSK: 16/32/36 kbps
4965	4940–4990	LMR PHY DSSS DPSK DSSS BPSK PHY
5300	5250–5350	
5600	5470–5725	
5700	5650–5925	
5800	5725–5850	

Insert the following new paragraph following the last paragraph of 8.1.1:

In the USA, devices operating in the 5300 MHz and 5600 MHz bands under FCC Title 47 CFR 15 Subpart E Unlicensed National Information Infrastructure employ both Transmit Power Control and Dynamic Frequency Selection, as per section 15.407.

8.1.2 Channel assignments

8.1.2.2 Channel numbering for 868 MHz, 915 MHz, and 2450 MHz bands

Change the first paragraph of 8.1.2.2 as indicated:

<Editor’s note: the following paragraph is in the process of being modified by 15.4k. The text shown below is a modification to the 4k text.>

This subclause does not apply to the SUN PHY, ~~or~~ LECIM PHY, or RCC PHY specifications. For explanations of channel numbering for the SUN PHYs and LECIM PHYs, see 8.1.2.9 and 8.1.2.14, respectively. For an explanation of channel numbering for the RCC PHY, see 8.1.2.14.

Insert the following new subclause (8.1.2.14) after 8.1.2.13:

8.1.2.14 Channel numbering for RCC PHY

A channel page (*phyCurrentPage*; 9.3) value of 13 indicates the RCC PHY.

The channel center frequency, $ChanCenterFreq$, for the RCC PHY shall be derived as follows:

$$ChanCenterFreq = ChanCenterFreq_0 + NumChan \times ChanSpacing$$

where

$ChanCenterFreq_0$ is the first channel center frequency in MHz

$ChanSpacing$ is the separation between adjacent channels in MHz

$NumChan$ is the channel number from 0 to $TotalNumChan-1$

$TotalNumChan$ is the total number of channels for the available frequency band

The parameters $ChanSpacing$, $TotalNumChan$, and $ChanCenterFreq_0$ for each frequency band is specified in Table 68m. The information in the table applies to all RCC modulation schemes.

Table 68m—Total number of channels and first channel center frequencies for RCC PHY

Band identifier	$ChanSpacing$ (MHz)	$TotalNumChan$	$ChanCenterFreq_0$ (MHz)
161	0.0075	187	160.1775
216	0.00625	159	216.00625
217	0.00625	479	217.00625
220	0.005	400	220.0025
450	0.00625	3199	450.00625
770	0.00625	960	769.003125
800	0.00625	960	799.003125
806	As defined in US CFR Title 47 (FCC), Part 90, Subpart S, section 90.613		
896	As defined in US CFR Title 47 (FCC), Part 90, Subpart S, section 90.613		
901	0.0125	79	901.0125
915	0.500	51	902.500
928	0.00625	5119	928.0125
4965	As defined in US CFR Title 47 (FCC), Part 90, Subpart Y, section 90.1213		
5300	0.5	199	5250.5
5600	0.5	499	5475.5
5700	0.5	275	5650.5
5800	0.5	249	5725.5

8.1.3 Minimum LIFS and SIFS periods

Change the first paragraph of 8.1.3 as indicated:

1 For all PHYs other than the UWB and RCC PHYs, the minimum LIFS period and SIFS period are:¹

2 — *macLIFSPeriod* – 40 symbols

3 — *macSIFSPeriod* – 12 symbols

4
5 ***Insert the following new paragraph after the first paragraph of 8.1.3:***

6
7 For the RCC PHY, the minimum LIFS period and SIFS period are:

8 — *macLIFSPeriod* – 5 symbols

9 — *macSIFSPeriod* – 5 symbols

10 11 12 **8.2 General radio specifications**

13 14 **8.2.7 Clear channel assessment (CCA)**

15
16 ***Change the third paragraph of 8.2.7 as indicated:***

17
18 The PHY PIB attribute *phyCCAMode*, as described in 9.3, shall indicate the appropriate operation mode.
19 The CCA parameters are subject to the following criteria:

- 20
21 a) Except for the MR-O-QPSK PHY, the ED threshold shall correspond to a received signal power of
22 at most 10 dB greater than the specified receiver sensitivity for that PHY. For the MR-O-QPSK
23 PHY, the ED threshold shall comply with the specification in 16.3.4.13.
- 24 b) Except for the 920 MHz band PHYs, ~~and the 950 MHz band PHYs,~~ and the RCC PHY, the CCA
25 detection time shall be equal to *aCCATime*, as defined in Table 70. For the 920 MHz band, ~~and the~~
26 950 MHz band PHYs, and the RCC PHY, *phyCCADuration* symbol periods shall be used.

27
28
29
30
31
32
33
34
35
36
37
38
39
40
41
42
43
44
45
46
47
48
49
50
51
52
53
54

¹For the MR-OFDM PHY, the MAC symbol duration is defined in 5.1.

9. PHY services

9.2 PHY constants

<Editor's note: the constant *aMaxPHYPacketSize* is in the process of being modified by 15.4k. The text shown is a modification to the 4k text.>

Change Table 70 (the entire table is not shown) as indicated:

Table 70—PHY constants

Constant	Description	Value
<i>aMaxPHYPacketSize</i>	The maximum PSDU size (in octets) the PHY shall be able to receive.	2047 for SUN ₂ and LECIM FSK ₂ and RCC LMR PHYs. For LECIM DSSS PHY, this is not a constant; refer to <i>phyLECIMDSSSPSDUSize</i> . 127 for all other PHYs

9.3 PHY PIB attributes

Change Table 71 (the entire table is not shown) as indicated:

Table 71—PHY PIB attributes

Attribute	Type	Range	Description
<i>phyCCADuration</i>	Integer	0–1000	The duration for CCA, specified in symbols. This attribute shall only be implemented with PHYs operating in the 920 MHz band and the 950 MHz band, and with the RCC PHY.

1
2
3
4
5
6
7
8
9
10
11
12
13
14
15
16
17
18
19
20
21
22
23
24
25
26
27
28
29
30
31
32
33
34
35
36
37
38
39
40
41
42
43
44
45
46
47
48
49
50
51
52
53
54

1
2
3
4
5
6
7
8
9
10
11
12
13
14
15
16
17
18
19
20
21
22
23
24
25
26
27
28
29
30
31
32
33
34
35
36
37
38
39
40
41
42
43
44
45
46
47
48
49
50
51
52
53
54

Insert after Clause 20 the following new clause (Clause 21):

21. RCC PHY

Two PHYs are specified in order to support RCC applications. The first is an LMR PHY with five possible modulation schemes: GMSK, as described in 21.1.5.1; C4FM, as described in 21.1.5.2; QPSK, as described in 21.1.5.3; and Pi/4 DQPSK, as described in 21.1.5.4; and DSSS employing DPSK, as described in 21.1.5.5. The second is a DSSS BPSK PHY, as described in 21.2.

21.1 LMR PHY specification

21.1.1 PPDU format

The LMR PHY PPDU shall be formatted as illustrated in Figure 154.

The synchronization header (SHR), PHY header (PHR), and PHY payload components are treated as bit strings of length n , numbered b_0 on the left and b_{n-1} on the right. When transmitted, they are processed b_0 first to b_{n-1} last, without regard to their content or structure.

Bits: 32/64	23			0/6	variable			0/3
	Data FEC Type (4 bits)	Data Length (11 bits)	CRC (8 bits)	PHR FEC Tail	PSDU (variable)	Payload FEC Tail (0/6 bits)	PAD (variable)	
SHR	PHR			PHY payload			GMSK tail	

Figure 154—Format of the RCC PPDU

21.1.1.1 SHR

The SHR shall be selected from the list of values shown in Table 72. The SHR is transmitted starting from the left-most bit.

Table 72—SHR values for RCC LMR PHY

Modulation	SHR value for FEC coded PHR	SHR value for FEC uncoded PHR
GMSK 9.6/19.2 kbps	1111 1000 0011 1000 1001 0000 1110 1101	0000 0111 1100 0111 0110 1111 0001 0010
C4FM 9.6/19.2/38.4 kbps	0101 0101 0111 1111 1111 01 0101 1111 1101 1111 0111 11 1111 0101 0111 0101 1101	1111 1111 1101 0101 0101 11 1111 0101 0111 0101 1101 01 0101 1111 1101 1111 0111
QPSK 16/32 Kbps	1100 1100 1100 1100 1100 11 1111 0000 0011 0000 1100 00 0000 1111 1100 1111 0011	1100 1100 1100 1100 1100 11 1111 0000 0011 0000 1100 11 1111 0000 0011 0000 1100

Table 72—SHR values for RCC LMR PHY

Modulation	SHR value for FEC coded PHR	SHR value for FEC uncoded PHR
Pi/4 DQPSK 16/32 Kbps	0101 0101 0111 1111 1111 01 0101 1111 1101 1111 0111 11 1111 0101 0111 0101 1101	1111 1111 1101 0101 0101 11 1111 0101 0111 0101 1101 01 0101 1111 1101 1111 0111
DSSS DBPSK	1010 1010 1011 1000 1001 0000 1110 1101	10 1010 1011 1000 1001 0111 0001 0010
DSSS DQPSK	1100 1100 1100 1100 1100 11 1111 0000 0011 0000 1100 00 0000 1111 1100 1111 0011	1100 1100 1100 1100 1100 11 1111 0000 0011 0000 1100 11 1111 0000 0011 0000 1100

21.1.1.2 PHR header

The Data FEC Type field indicates the coding rate used in the PSDU field, and it shall be assigned according to Table 73; see 21.1.2 for more information on coding. The left most bit shall be transmitted first.

Table 73—Data FEC Type field for RCC LMR PHY

Data FEC Type field value	Coding rate
0000	1 (no FEC)
0001	7/8
0010	3/4
0011	2/3
0100	1/2
0101–1111	Reserved

The Data Length field specifies the total number of octets contained in the PSDU. The MSB shall be transmitted first.

The Data FEC Type and Data Length fields shall be protected with an 8-bit CRC. The CRC shall be the remainder generated by the modulo 2 division of the protected fields by the polynomial:

$$x^8 + x^2 + x + 1$$

The protected bits shall be processed in transmit order. All CRC calculations shall be made prior to data whitening. A schematic of the processing is shown in Figure 155.

When FEC is applied to the PHR, the PHR FEC Tail field shall have a length of 6 bits (i.e., six FEC tail bits are appended after the CRC field to aid in FEC decoding). When the PHY header is not FEC protected, the PHR FEC Tail field shall have length zero (i.e., no tail bits are appended).

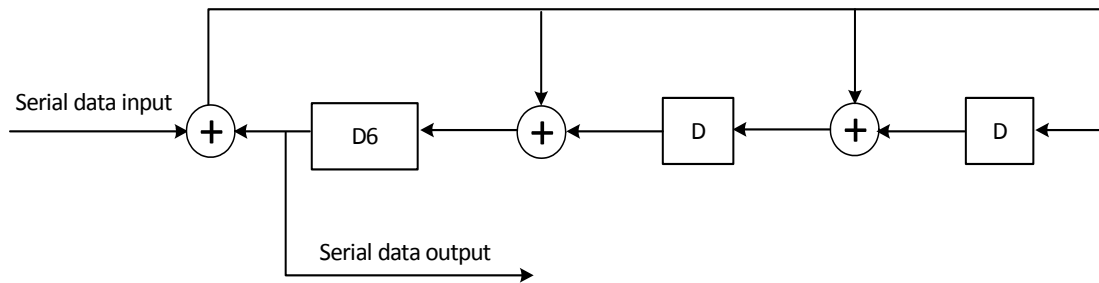

Figure 155—CRC-8 implementation for RCC LMR PHY

21.1.1.3 PHY payload

The Data FEC Type field determines whether the PSDU is FEC protected. The Payload FEC Tail field shall be present only if the PSDU is FEC protected.

The length of the PAD field depends on the selected coding rate. The total number of bits contained in the PSDU, Payload FEC Tail, and PAD fields shall be an integer multiple of the puncturing pattern according to Figure 157.

21.1.1.4 GMSK tail

Three extra zero bits are appended at the end of the packet for Gaussian filter response time if GMSK modulation is used. No GMSK tail bits shall be appended for other modulation modes.

21.1.2 Forward error correction (FEC)

FEC protection of the PHR shall be supported. When FEC is enabled, a $\frac{1}{2}$ code rate convolutional code shall be used.

The PSDU shall be coded using one of the values contained in Table 73, corresponding to the desired data rate. The convolutional encoder shall use generator polynomials $g_0 = 133_8$ and $g_1 = 171_8$ for rate $\frac{1}{2}$, as shown in Figure 156. Higher rates are achieved by puncturing, according to Figure 157.

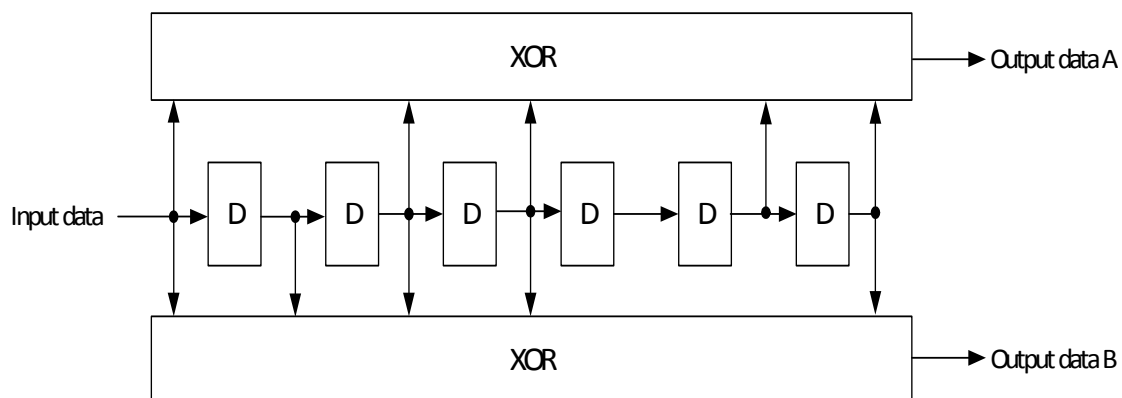

Figure 156—Convolutional encoder for RCC LMR PHY

1
2
3
4
5
6
7
8
9
10
11
12
13
14
15
16
17
18
19
20
21
22
23
24
25
26
27
28
29
30
31
32
33
34
35
36
37
38
39
40
41
42
43
44
45
46
47
48
49
50
51
52
53
54

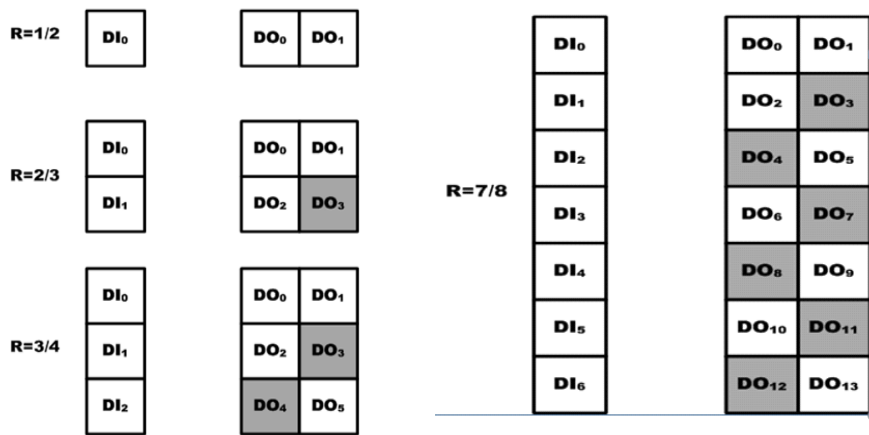

Figure 157—FEC puncturing pattern for RCC LMR PHY

21.1.3 Interleaver

Interleaving of the PHY payload shall be supported. Interleaving may be enabled when FEC is enabled. Interleaving shall be disabled when FEC is disabled.

The process of interleaving is illustrated in Figure 158.

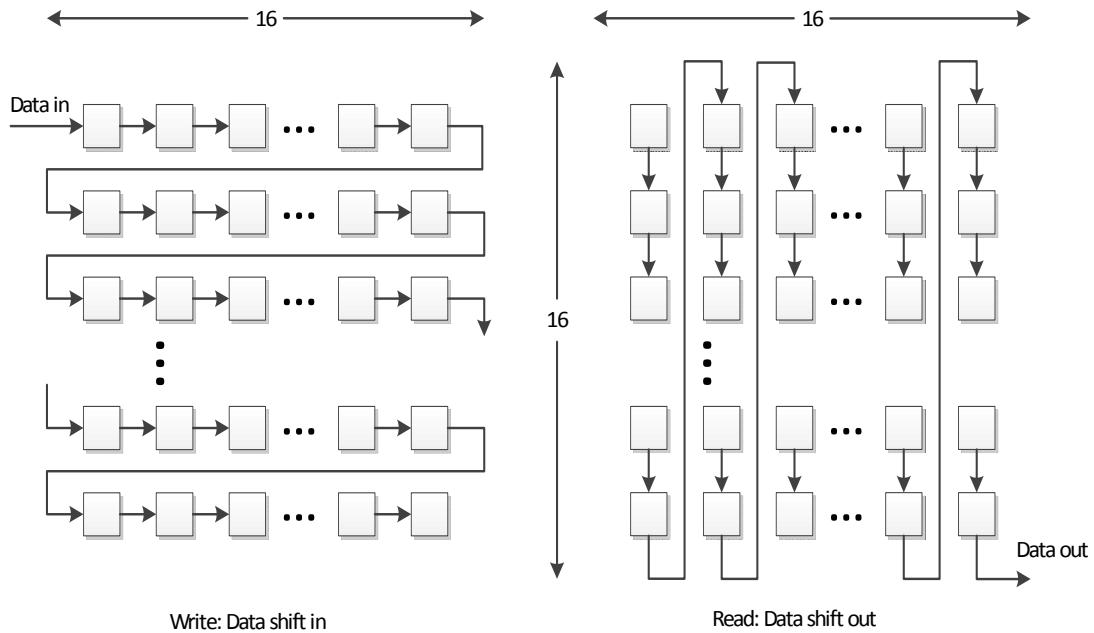

Figure 158—Interleaver for RCC LMR PHY

21.1.4 Data whitening

Data whitening shall be applied to the PHR and PHY payload. See 16.1.3 for more details.

The PN9 sequence generator shall not be reset between the PHR and the PSDU.

21.1.5 Modulation

The modulation scheme and data rate shall be configured using the RCC PHY Operating Mode Description IE, as described in 5.2.4.29.3.

21.1.5.1 GMSK

GMSK is MSK modulation with Gaussian filtering. MSK is a special case of continuous phase FSK, and its modulation index is exactly 0.5.

The modulated waveform may be represented as:

$$s(t) = A \cos(\omega_0 t + \phi(t))$$

where

A is the signal amplitude

ω_0 is the carrier angular frequency

$\phi(t)$ is the signal phase

The signal phase $\phi(t)$ may be represented by the data bit stream $d_0, d_1, d_2 \dots$ as:

$$\phi(t) = \phi_0 + \frac{\pi}{2} \int \left[G(t) * \sum_i k_i \text{rect}(t - iT) \right] dt$$

where

$$G(t) = \frac{1}{\sigma T \sqrt{2\pi}} \exp\left(\frac{-t^2}{2\sigma^2 T^2}\right) \text{ with } \sigma = \frac{\sqrt{\ln(2)}}{2\pi BT}$$

$$k_i = \begin{cases} 1 & \text{if } d_i = 1 \\ -1 & \text{if } d_i = 0 \end{cases}$$

$$\text{rect}(t) = \begin{cases} (1/T) & \text{for } 0 < t < T \\ 0 & \text{otherwise} \end{cases}$$

T is the symbol period

ϕ_0 is the initial phase

The initial phase ϕ_0 may take any value. It is not specified and is, therefore, unknown to the receiver.

Figure 159 shows a typical GMSK modulation in digital implementation. This functional block diagram serves as a reference for specifying the RCC LMR PHY with GMSK modulation.

Data "1" shall have positive frequency deviation. Data "0" shall have negative frequency deviation.

The default BT value shall be 0.3, since it provides good adjacent channel power ratio in order to meet spectrum masks in narrow band applications such as US FCC Part 90. Lower BT values provide narrower spectrum width, but the eye opening is narrower and may degrade receiver decoding. A larger BT may

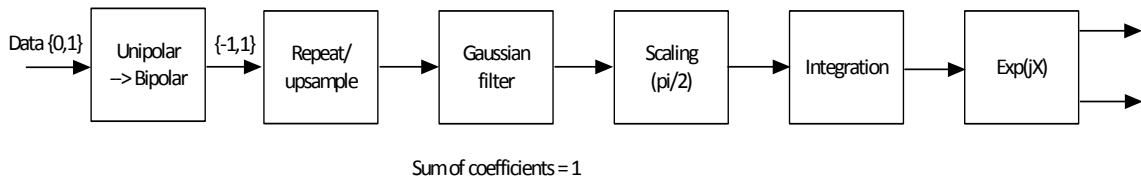

10
11
12
13
14
15
16
17
18
19
20
21
22
23
24
25
26
27
28
29
30
31
32
33
34
35
36
37
38
39
40
41
42
43
44
45
46
47
48
49
50
51
52
53
54

Figure 159—Typical GMSK modulator for RCC LMR PHY

optionally be used where regulations permit. Typical power spectrum density of MSK and GMSK is shown in Figure 160. The eye diagrams are shown in Figure 161, Figure 162, and Figure 163.

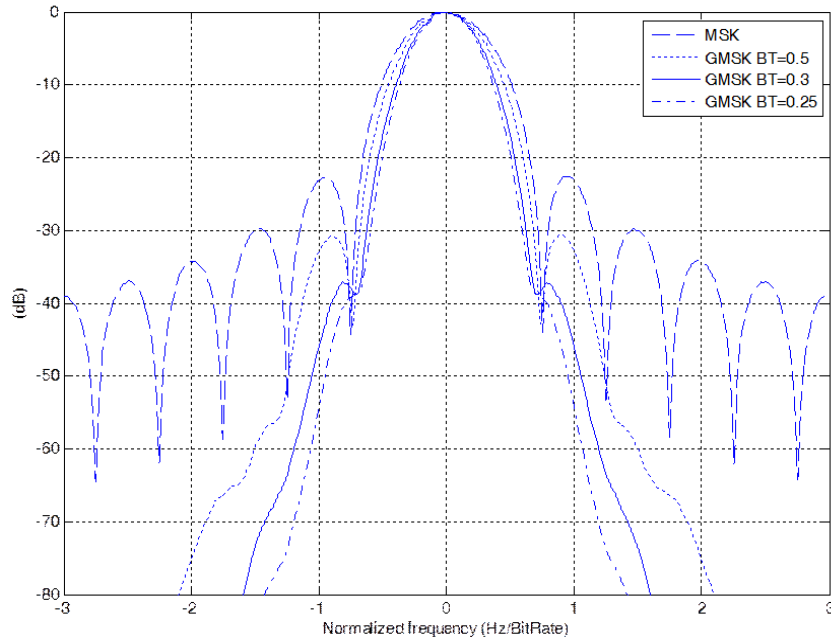

Figure 160—Typical GMSK power spectrum density

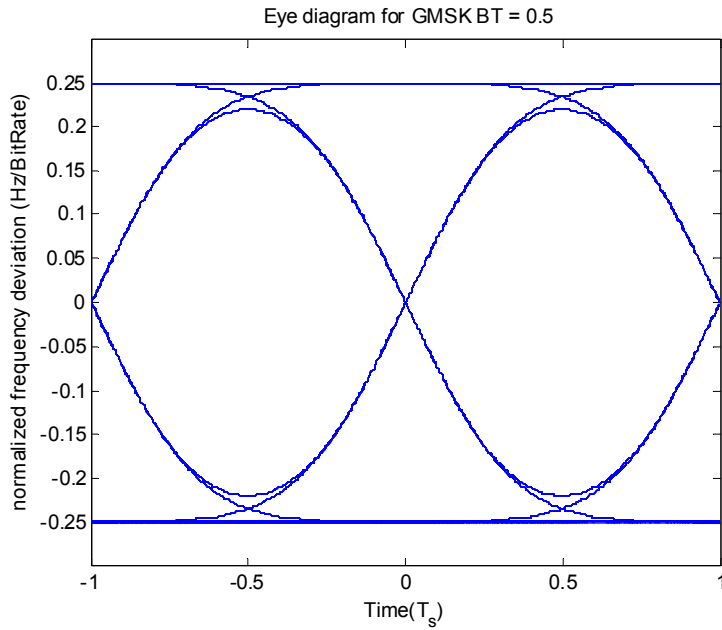

Figure 161—Eye diagram for GMSK with BT=0.5

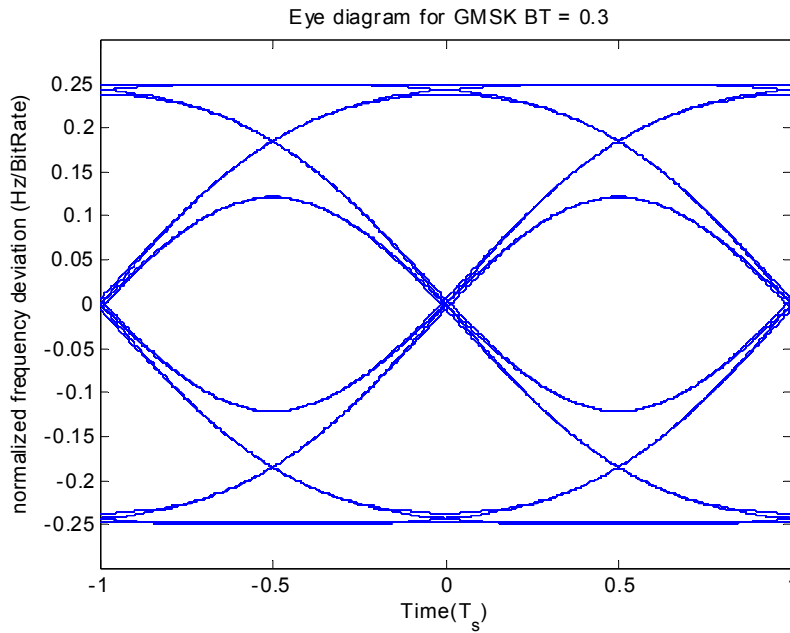

Figure 162—Eye diagram for GMSK with BT=0.3

1
2
3
4
5
6
7
8
9
10
11
12
13
14
15
16
17
18
19
20
21
22
23
24
25
26
27
28
29
30
31
32
33
34
35
36
37
38
39
40
41
42
43
44
45
46
47
48
49
50
51
52
53
54

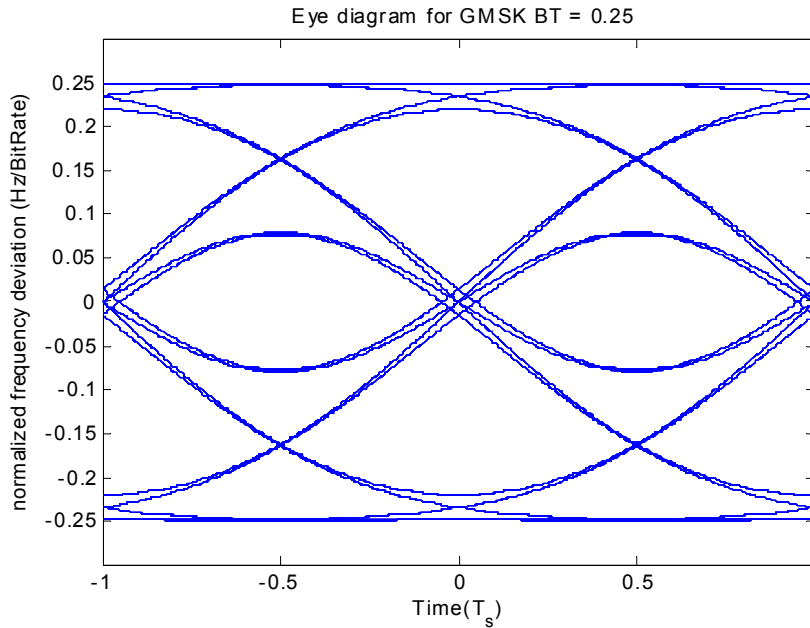

Figure 163—Eye diagram for GMSK with BT=0.25

21.1.5.2 C4FM

C4FM is a four-level frequency modulation with continuous phase. Figure 164 shows a typical C4FM modulator in digital implementation. This functional block diagram serves as a reference for specifying the LMR PHY with C4FM modulation.

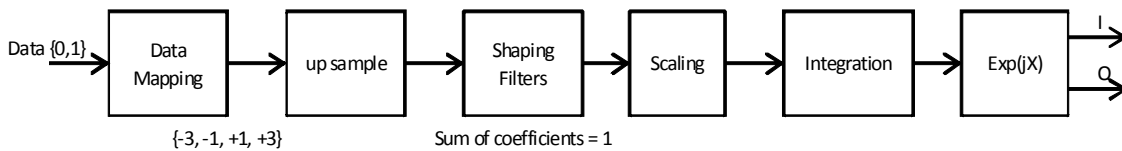

Figure 164—Typical C4FM modulator for RCC LMR PHY

The shaping filters consists of a Nyquist raised cosine filter cascaded with an inverse-sinc filter. The frequency response of the Nyquist raised cosine filter $H(f)$ is given by:

$$|H(f)| = 1, \quad \text{for } |f| < \text{symbol rate} \times 0.4$$

$$|H(f)| = 0.5 + 0.5 \cos \left[\frac{2 \times \pi \times f}{\text{symbol rate} \times 0.4} \right], \quad \text{for } (\text{symbol rate} \times 0.4) < |f| < (\text{symbol rate} \times 0.6)$$

$$|H(f)| = 0, \quad \text{for } (|f| > \text{symbol rate} \times 0.6)$$

The group delay of the Nyquist raised cosine filter is flat over the pass band for $|f| < \text{symbol rate} \times 0.6$.

The amplitude response of the inverse-sinc filter $P(f)$ is given by:

$$|P(f)| = \left[\frac{\left(\frac{\pi \times f}{\text{symbol rate}} \right)}{\left(\frac{\sin(\pi \times f)}{\text{symbol rate}} \right)} \right], \quad \text{for } |f| < (\text{symbol rate} \times 0.6)$$

The response of $P(f)$ for $|f| > \text{symbol rate} \times 0.6$ is not specified for frequencies above $\text{symbol rate} \times 0.6$, since these frequencies are cut off by $H(f)$.

The data mapping and frequency deviation is indicated in Table 74. The value of the scaling block shown in Figure 164 should be chosen properly to match the corresponding frequency deviation.

Table 74—C4FM frequency deviation for RCC LMR PHY

Data $\{b_1, b_0\}$	Frequency deviation (normalize to symbol rate)
01	+3/8
00	+1/8
10	-1/8
11	-3/8

21.1.5.3 QPSK

Figure 165 shows a typical QPSK modulator in digital implementation. This functional block diagram serves as a reference for specifying the LMR PHY with QPSK modulation. The bit-to-symbol mapping shall be encoded according to Figure 166. The default pulse shaping filter shall be a root cosine filter with a roll-off factor of 0.25.

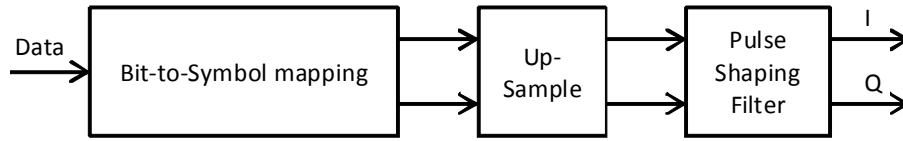

Figure 165—Typical QPSK modulator for RCC LMR PHY

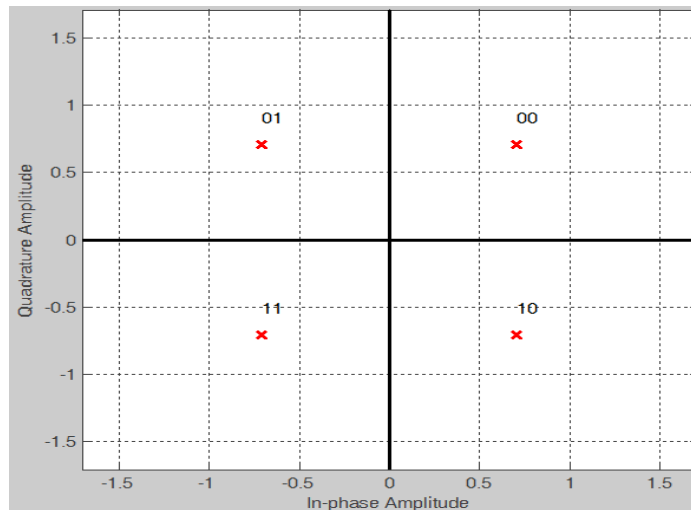

Figure 166—Bit-to-symbol mapping for QPSK (RCC LMR PHY)

21.1.5.4 Pi/4 DQPSK

Figure 167 shows a typical Pi/4 DQPSK modulator in digital implementation. This functional block diagram is provided as a reference for specifying the LMR PHY using Pi/4 DQPSK modulation. The bit-to-symbol mapping and differential encoding shall be encoded according to Table 75. The default pulse shaping filter shall be a root raised cosine filter with a roll-off factor of 0.25.

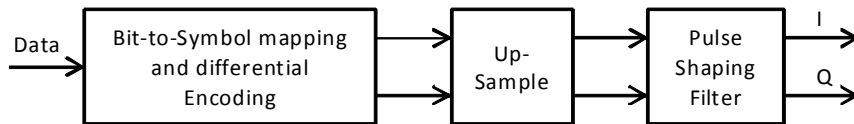

Figure 167—Typical Pi/4 DQPSK modulator for RCC LMR PHY

A typical power spectrum density is shown in Figure 168. The spectrum skirt is caused by time domain truncation of the shaping pulse and is design dependent.

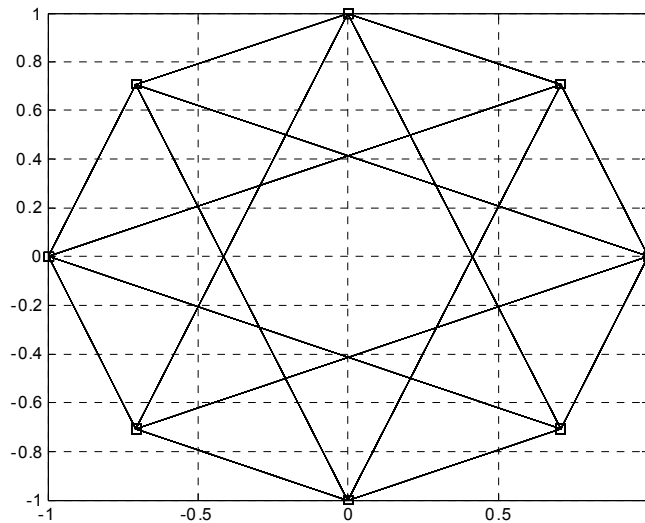

Figure 168—Signal constellation of Pi/4 DQPSK for RCC LMR PHY

Table 75—Pi/4 DQPSK encoding values for RCC LMR PHY

Data $\{b_1, b_0\}$	Phase change
01	$+3/4 \times \pi$
00	$+1/4 \times \pi$
10	$-1/4 \times \pi$
11	$-3/4 \times \pi$

21.1.5.5 DSSS DPSK

The modulation for DSSS DPSK is either DSSS DBPSK or DSSS DQPSK.

The functional block diagram shown in Figure 169 is provided as a reference for specifying the DSSS DPSK modulation and spreading functions.



Figure 169—DSSS DPSK modulation and spreading

1
2
3
4
5
6
7
8
9
10
11
12
13
14
15
16
17
18
19
20
21
22
23
24
25
26
27
28
29
30
31
32
33
34
35
36
37
38
39
40
41
42
43
44
45
46
47
48
49
50
51
52
53
54

The bit-to-symbol mapping and differential encoding for DSSS DBPSK shall be encoded according to Table 76.

Table 76—DSSS DBPSK encoding table

Data	Phase change
0	0
1	π

The bit-to-symbol mapping and differential encoding for DSSS DQPSK shall be encoded according to Table 77.

Table 77—DSSS DQPSK encoding table

Dibit pattern (d_0, d_1) [*]	Phase change
00	0
01	$\frac{\pi}{2}$
11	π
10	$-\frac{\pi}{2}$

^{*}Bit d_0 is transmitted first in time.

The spreading sequences are specified in Table 78. The leftmost chip shall be output first in time.

Table 78—DSSS DPSK spreading sequences

Spreading sequence length	Spreading sequence
11	111 0001 0010
15	101 1111 0100 0110
20	1010 1000 0011 0110 0111
40	1010 0011 1001 0010 1101 1101 1001 1010 1011 1111

The chip rates are specified in Table 79.

1
2
3
4
5
6
7
8
9
10
11
12
13
14
15
16
17
18
19
20
21
22
23
24
25
26
27
28
29
30
31
32
33
34
35
36
37
38
39
40
41
42
43
44
45
46
47
48
49
50
51
52
53
54

Table 79—DSSS DPSK chip rates

DSSS DPSK chip rates
300 kcps
600 kcps
800 kcps
1 Mcps
1.6 Mcps
2 Mcps
3 Mcps
4 Mcps

21.1.6 Reference modulator diagram

The functional block diagram in Figure 170 serves as a reference for specifying the LMR PHY data flow processing functions. Data whitening shall be applied over the PHR and PHY payload continuously. The six FEC tail bits shall be replaced by six non-scrambled zeros prior to FEC encoding. When FEC is enabled, FEC processing for the PHR and PHY payload shall be performed separately.

All fields in the PPDU shall use the same symbol rate and modulation.

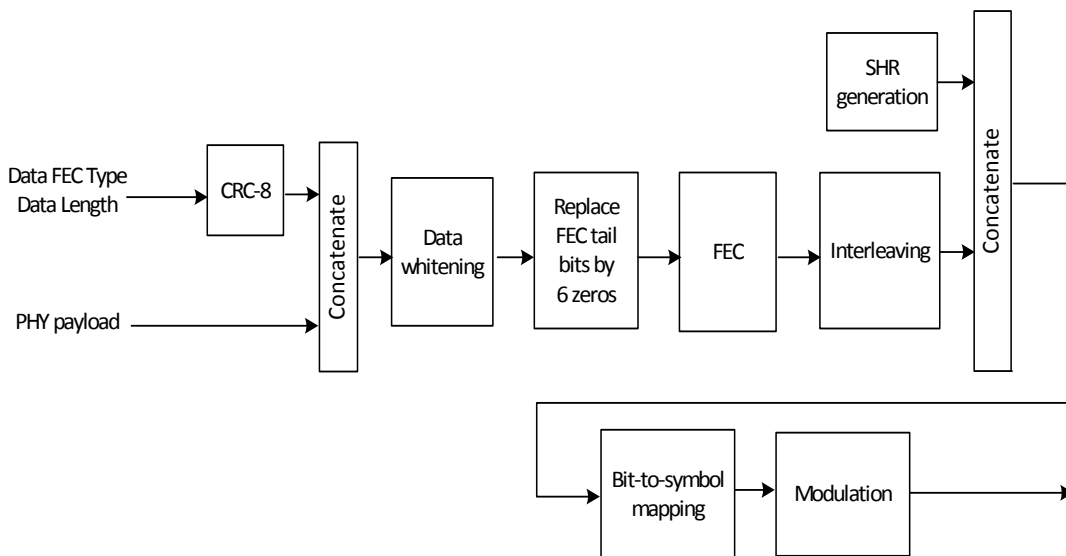

Figure 170—RCC LMR PHY reference modulator diagram

1
2
3
4
5
6
7
8
9
10
11
12
13
14
15
16
17
18
19
20
21
22
23
24
25
26
27
28
29
30
31
32
33
34
35
36
37
38
39
40
41
42
43
44
45
46
47
48
49
50
51
52
53
54

21.1.7 LMR PHY RF requirements

21.1.7.1 Radio frequency tolerance

The center frequency error shall conform with local regulations or be less than or equal to ± 1 ppm, whichever is tighter.

21.1.7.2 Transmitter symbol rate tolerance

The transmitter symbol rate error shall be less than or equal to ± 1 ppm.

21.1.7.3 Channel switching time

The channel switching time shall be less than or equal to 500 μ s .

21.1.7.4 Transmit power spectral density (PSD) mask

The LMR PHY transmit spectral mask shall conform with local regulations.

21.1.7.5 Error vector magnitude

When the LMR PHY is using either QPSK or Pi/4 DQPSK modulation, it shall have EVM values of less than 35% when measured for 1000 symbols using the measurement process defined in 8.2.3.

21.1.7.6 Transmit power

The maximum transmit power is limited by local regulatory bodies.

21.1.7.7 Receiver sensitivity

Receiver sensitivity is implementation specific, however, the method for measuring receiver sensitivity is described in 8.1.7.

21.1.7.8 Receiver interference rejection

The minimum receiver interference rejection is implementation specific.

21.1.7.9 Receiver maximum input level of desired signal

The receiver maximum input level is implementation specific.

21.1.7.10 TX-to-RX turnaround time

The TX-to-RX turnaround time shall be less than or equal to 500 μ s .

21.1.7.11 RX-to-TX turnaround time

The RX-to-TX turnaround time shall be less than or equal to 500 μ s .

21.1.7.12 Receiver energy detection (ED)

The LMR PHY shall provide the receiver ED measurement, as described in 8.2.5.

1
2
3
4
5
6
7
8
9
10
11
12
13
14
15
16
17
18
19
20
21
22
23
24
25
26
27
28
29
30
31
32
33
34
35
36
37
38
39
40
41
42
43
44
45
46
47
48
49
50
51
52
53
54

21.1.7.13 Link quality indicator (LQI)

The LMR PHY shall provide the LQI measurement, as described in 8.2.6.

21.1.7.14 Clear channel assessment (CCA)

The LMR PHY shall use one of the CCA methods described in 8.2.7.

21.2 DSSS BPSK PHY specification

The DSSS BPSK PHY shall employ the BPSK PHY specified in Clause 11, with the exception that the spreading sequence is changed to 101 1010 1100 1000.

1
2
3
4
5
6
7
8
9
10
11
12
13
14
15
16
17
18
19
20
21
22
23
24
25
26
27
28
29
30
31
32
33
34
35
36
37
38
39
40
41
42
43
44
45
46
47
48
49
50
51
52
53
54

1
2
3
4
5
6
7
8
9
10
11
12
13
14
15
16
17
18
19
20
21
22
23
24
25
26
27
28
29
30
31
32
33
34
35
36
37
38
39
40
41
42
43
44
45
46
47
48
49
50
51
52
53
54

Annex D

(informative)

Protocol implementation conformance statement (PICS) proforma²

Subclause D.2 is reproduced here to assist the reader in understanding the abbreviations and special symbols in this annex. No changes are made to D.2.

D.2 Abbreviations and special symbols

Notations for requirement status:

- M Mandatory
- O Optional
- O.n Optional, but support of at least one of the group of options labeled O.n is required.
- N/A Not applicable
- X Prohibited
- “item”: Conditional, status dependent upon the support marked for the “item”

For example, FD1: O.1 indicates that the status is optional but at least one of the features described in FD1 and FD2 is required to be implemented, if this implementation is to follow the standard to which this PICS proforma is part.

D.7 PICS proforma tables

D.7.1 Functional device types

Insert the following new row to the end of Table D.1 (the rest of the table is not shown) as indicated:

Table D.1—Functional device types

Item number	Item description	Reference	Status	Support		
				N/A	Yes	No
FD10	RCC PHY device	8.1	O.3			
O.3: At least one of these features is supported.						

D.7.2 Major capabilities for the PHY

D.7.2.1a PHY packet

²Copyright release for PICS proformas: Users of this standard may freely reproduce the PICS proforma in this annex so that it can be used for its intended purpose and may further publish the completed PICS.

Change Table D.2a as indicated:

Table D.2a—PHY packet

Item number	Item description	Reference	Status	Support		
				N/A	Yes	No
PLP1	PSDU size up to 2047 octets	9.2	FD6, <u>FD10</u> : M			

D.7.2.2 Radio frequency (RF)

Insert the following new rows at the end of Table D.3:

Table D.3—Radio frequency (RF)

Item number	Item description	Reference	Status	Support		
				N/A	Yes	No
RF21	RCC PHYs					
RF21.1	GMSK	21.1.5.1	FD10: O.11			
RF21.2	C4FM	21.1.5.2	FD10: O.11			
RF21.3	QPSK	21.1.5.3	FD10: O.11			
RF21.4	Pi/4 DQPSK	21.1.5.4	FD10: O.11			
RF21.5	DSSS DPSK	21.1.5.5	FD10: O.11			
RF21.6	DSSS BPSK	21.2	FD10: O.11			
RF21.7	At least one of the bands given in Table 66c	8.1	FD10: M			
RF21.8	FEC	21.1.2	RF21.1: M, RF21.2: M, RF21.3: M, RF21.4: M, RF21.5: M			
RF21.9	Interleaving	21.1.3	RF21.1: M, RF21.2: M, RF21.3: M, RF21.4: M, RF21.5: M			
RF21.10	Data whitening	21.1.4	RF21.1: M, RF21.2: M, RF21.3: M, RF21.4: M, RF21.5: M			
O.11: At least one of these modulation schemes is supported.						