

Project: IEEE P802.15 Working Group for Wireless Personal Area Networks (WPANs)

Submission Title: [Full Proposal on PHY and MAC for IEEE 802.15.4m]

Date Submitted: [July, 2012]

Source: [Hiroshi Harada, Fumihide Kojima, Ryuhei Funada, Alina Lu Liru, Ming-Tuo Zhou, Zhou Lan, Chin-Sean Sum]

Company [NICT]

Address [3-4, Hikarino-oka, Yokosuka, 239-0847 Japan.]

Voice: [+81-46-847-5092], FAX: [+81-46-847-5440], E-Mail: [sum@nict.go.jp]

Re: [Full Proposal on PHY and MAC Layer Designs for IEEE 802.15.4m.]

Abstract: [This document presents the NICT full proposal for TG4m PHY and MAC layer design]

Purpose: [This document provides a list of the editing staff that will be working on 802.15.4m.]

Notice: [This document has been prepared to assist the IEEE P802.15. It is offered as a basis for discussion and is not binding on the contributing individual(s) or organization(s). The material in this document is subject to change in form and content after further study. The contributor(s) reserve(s) the right to add, amend or withdraw material contained herein.]

Release: [The contributor acknowledges and accepts that this contribution becomes the property of IEEE and may be made publicly available by P802.15.]

Executive Summary

- This document presents combined PHY and MAC proposals for TG4m
- The PHY proposals consist of
 - FSK PHY based on TG4g FSK PHY with alternative FEC and Interleaver
 - Two plus Four OFDM PHY modes as options: Two are based on one-segment broadcasting system which is in service in Japan; Four are based on TG4g MR-OFDM
 - Channel plan on a consideration of FCC regulatory limits
- The MAC proposals consists of
 - TVWS Operation Enabling Protocol: to equip TG4m device with the capability to comply with TVWS rules
 - Dynamic Band Switching: to equip TG4m device with out-of-band communication capability
 - Power Saving Mechanism: to equip TG4m device with scalable power saving features
 - Direct Device-to-device Data Transfer: to equip TG4m device with peer-to-peer communication capability for network redundancy
 - Co-existence among TG4m MAC modifications

PHY PROPOSAL

Executive Outline - PHY

- FSK PHY
 - Based on TG4g FSK PHY
 - Alternate FEC and interleaver
- OFDM PHY
 - Two plus Four OFDM PHY modes proposed as options
 - Two based on one-segment broadcasting system
 - Four using TG4g MR-OFDM options
- Channel Plan
 - Based on a consideration of FCC regulatory limits

FSK PHY Proposal

Summary of TG4m FSK PHY Proposal

- Major TG4g PHY FSK specifications followed
 - Filtered 2FSK and filtered 4FSK
- Alternate FEC and Interleaver
 - Concatenated code of Reed Solomon (RS) and Convolutional Code (CC) and revised bit interleaver
- Channel Plan
 - Associated with Frequency Hopping(FH) as an option
- PPDU and PHR formats

FSK PHY Modes

- Data rates and parameters supported are same as in TG4g specifications

| | Mode #1 | Mode #2 | Mode #3 | Mode #4 |
|-----------------------|-------------------|-------------------|-------------------|-------------------|
| Data rate (kbps) | 50 | 100 | 200 | 400 |
| Modulation | Filtered 2 FSK | Filtered 2 FSK | Filtered 2 FSK | Filtered 4 FSK |
| Modulation Index | 1 | 1 | 1 | 0.33 |
| Channel spacing (kHz) | 200 | 400 | 600 | 600 |

Proposed FEC for FSK PHY

- Concatenated code of RS and systematic CC
 - Outer coder: RS(204,188,8) used in DVB-T and being able to correct no more than 8 symbol (each of which is composed of 8 bits)
 - Inner coder: Systematic CC ($R=1/2$ & $K=7$) to replace the one applied in TG4g FSK
 - Only 0.2 dB degradation from non-systematic convolutional encoder (133,171)
 - As a same manner of TG4g FEC, **FEC enabled and disabled selection applicable in receiver**
 - **4 options to decode**: Only RS decode, Only Viterbi decode, RS + Viterbi, hard decision recover without them
 - Applied to the lowest data rate mode

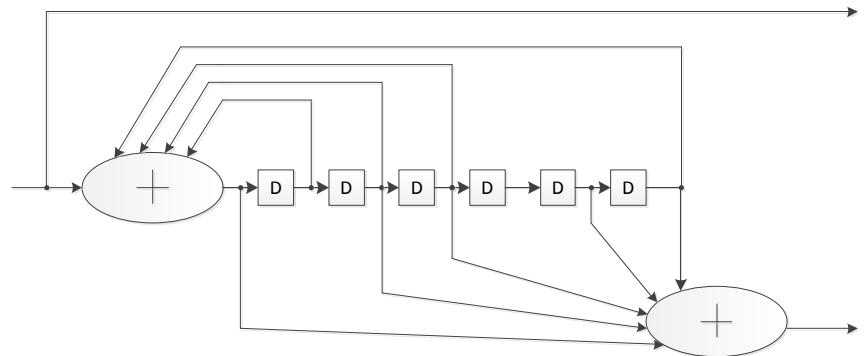

Proposed Bit Interleaver for FSK PHY

8 by 4 block interleaver as shown below

| | | | | | | | |
|---|---|---|-----|-----|----|----|------|
| 1 | 2 | 3 | ... | ... | | | → |
| | | | | | | | → |
| | | | | | | | → |
| | | | | ... | 30 | 31 | 32 → |

Row by row write in

| | | | | | | | |
|---|---|---|-----|-----|------|------|------|
| 1 | 2 | 3 | ... | ... | | | |
| | | | | | | | |
| | | | | | | | |
| ↓ | ↓ | ↓ | ↓ | ... | 30 ↓ | 31 ↓ | 32 ↓ |

Column by column read out

Channel Plan and FH for FSK PHY (1/2)

- 6MHz bandwidth with 3 modes as follows:
 - 29 channels with center frequencies starting from 0.2MHz @Ch₂₀₀#0 to 5.8MHz@Ch₂₀₀#28 with 200kHz channel spacing
 - 14 channels with center freq. starting from 0.4 MHz @Ch₄₀₀#0 to 5.6MHz @Ch₄₀₀#13 with 400kHz channel spacing
 - 9 channels with center freq. starting from 0.6 MHz @Ch₆₀₀#0 to 5.4MHz @Ch₆₀₀#8 with 600kHz channel spacing
- FH supported for the mode using 200kHz and 400kHz channel spacing as options

Channel Plan and FH for FSK PHY (2/2)

- For the mode using 200kHz channel spacing, 6MHz channel divided into 4 subchannels and 5 hops in each
- For the mode using 400kHz channel spacing, 6MHz channel divided into 4 subchannels, and 3 hops in each

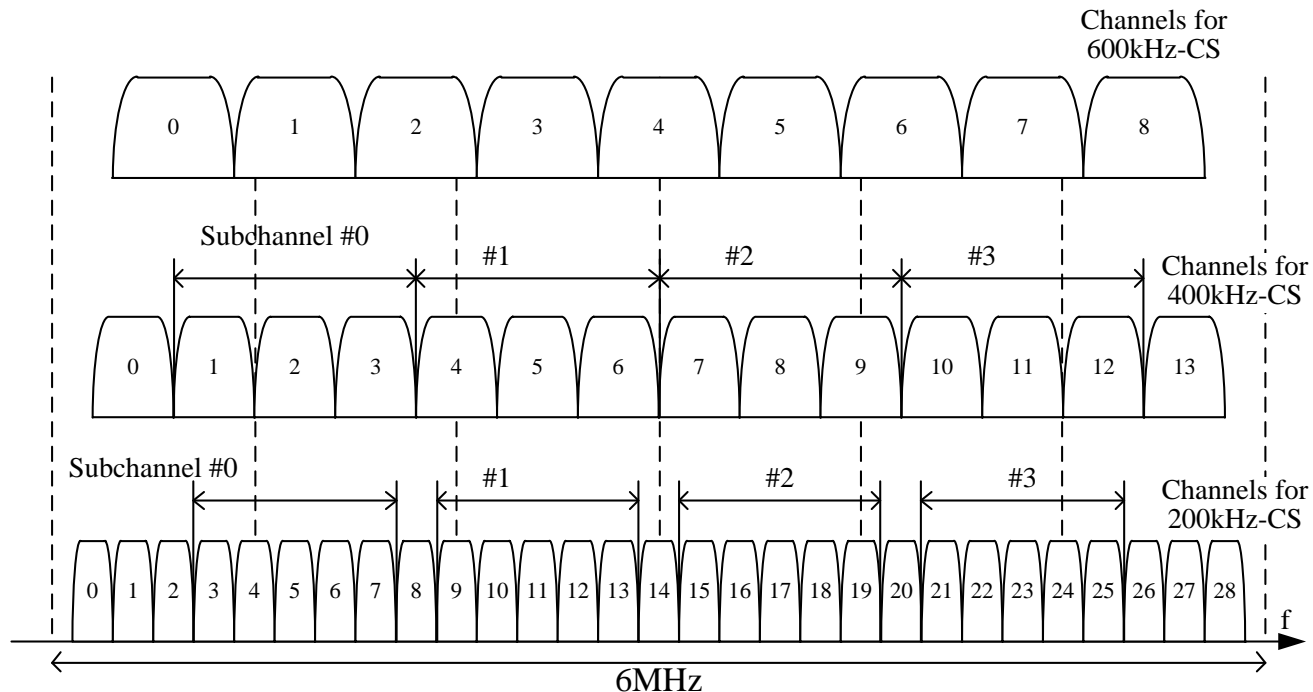

Proposed PPDU/PHR Format for FSK PHY

- PPDU Format for FSK PHY: same as of TG4g FSK PHY

| | | | |
|----------|----------|----------|----------|
| Variable | 2 octets | 2 Octets | Variable |
| SHR | | PHR | PPDU |
| Preamble | SFD | | |

- PHR

| Bit String Index | 0 | 1-3 | 3 | 5-15 |
|------------------|--------------|-----------|----------------|--------------|
| Bit Mapping | PC | R3-R0 | DW | L10-L0 |
| Field Name | Parity Check | Reserv ed | Data Whitening | Frame length |

OFDM PHY Proposal

Summary of OFDM PHY Proposal

- **Two plus Four** OFDM PHY Modes Proposed as options
 - Modes #1 and #2: one-segment broadcasting based modes
 - Modes #3 to #6: using TG4g MR-OFDM options except for some of modified channel spacing

Proposed OFDM PHY Major Specifications (1/2)

-One-segment broadcasting based system-

| | Mode #1 | Mode #2 |
|--|---|---------|
| Channel bandwidth | 6MHz | 8MHz |
| Nominal bandwidth (kHz) | 380.95 | |
| No. of sub-channels | 11 | 16 |
| Channel spacing (kHz) | 400 | |
| Subcarrier spacing (kHz) | 0.99206 | |
| Guard band for each side of channel (kHz) | 800kHz | |
| No. of effective. subcarriers per subchannel | 384 | |
| No. of pilot subcarrier per subchannel | 32 | |
| No. of data subcarriers per subchannel | 352 | |
| Effective symbol length (μ s) | 1008 | |
| Guard interval length | 1/32 (31.5 μ s) as a default 1/16 (63.0 μ s) as a option | |

Proposed OFDM PHY Major Specifications (2/2)

-TG4g MR-OFDM based system-

| | Mode #3 | Mode #4 | Mode #5 | Mode #6 |
|--|---------|---------|---------|---------|
| Channel bandwidth | 6MHz | | | |
| Nominal bandwidth (kHz) | 1094 | 552 | 281 | 156 |
| DFT size | 128 | 64 | 32 | 16 |
| Channel spacing (kHz) | 1200 | 600 | 400 | 200 |
| Subcarrier spacing (kHz) | 10.4167 | | | |
| Guard band | | | | |
| No. of effective. subcarriers per subchannel | 104 | 52 | 26 | 14 |
| No. of pilot subcarrier per subchannel | 8 | 4 | 2 | 2 |
| No. of data subcarriers per subchannel | 96 | 48 | 24 | 12 |

MCS Summary of OFDM Modes #1 and #2

- Modulation and Coding Scheme
 - Modulation:
 - BPSK QPSK, 16QAM, and 64QAM with bit block interleaving for subcarrier modulation
 - FEC: Concatenated code of RS (204,188) and systematic CC
 - Same RS as in the proposed FSK
 - Systematic CC, with variable coding rate ranging from $1/2$ to $7/8$ with $K=7$, generated from same convolutional coder in the proposed FSK

Data Rates Supported on OFDM Modes #1 and #2

- Data rates supported per 400kHz subchannel as follows
 - Outer code of RS(204,188) in all MCSs and 1/32 cyclic prefix used

| MCS Index | Modulation | Inner Code: CC coding rate | Data Rate (Kbps) |
|-----------|------------|----------------------------|------------------|
| MCS0 | BPSK | 1/2 | 156 |
| MCS1 | BPSK | 3/4 | 234 |
| MCS2 | QPSK | 1/2 | 312 |
| MCS3 | QPSK | 3/4 | 468 |
| MCS4 | 16-QAM | 1/2 | 624 |
| MCS5 | 16-QAM | 3/4 | 936 |
| MCS6 | 64-QAM | 2/3 | 1404 |
| MCS7 | 64-QAM | 3/4 | 1248 |
| MCS8 | 64-QAM | 7/8 | 1638 |

Proposed Bit Interleaver of OFDM Modes #1 and #2

- Different size of bit block interleaver for 3 types of modulations (i.e., BPSK, QPSK, 16QAM, and 64QAM), which are associated with one OFDM symbol

Pilot Allocation and Subcarrier Mapping of OFDM Modes #1 and #2

Carrier Number

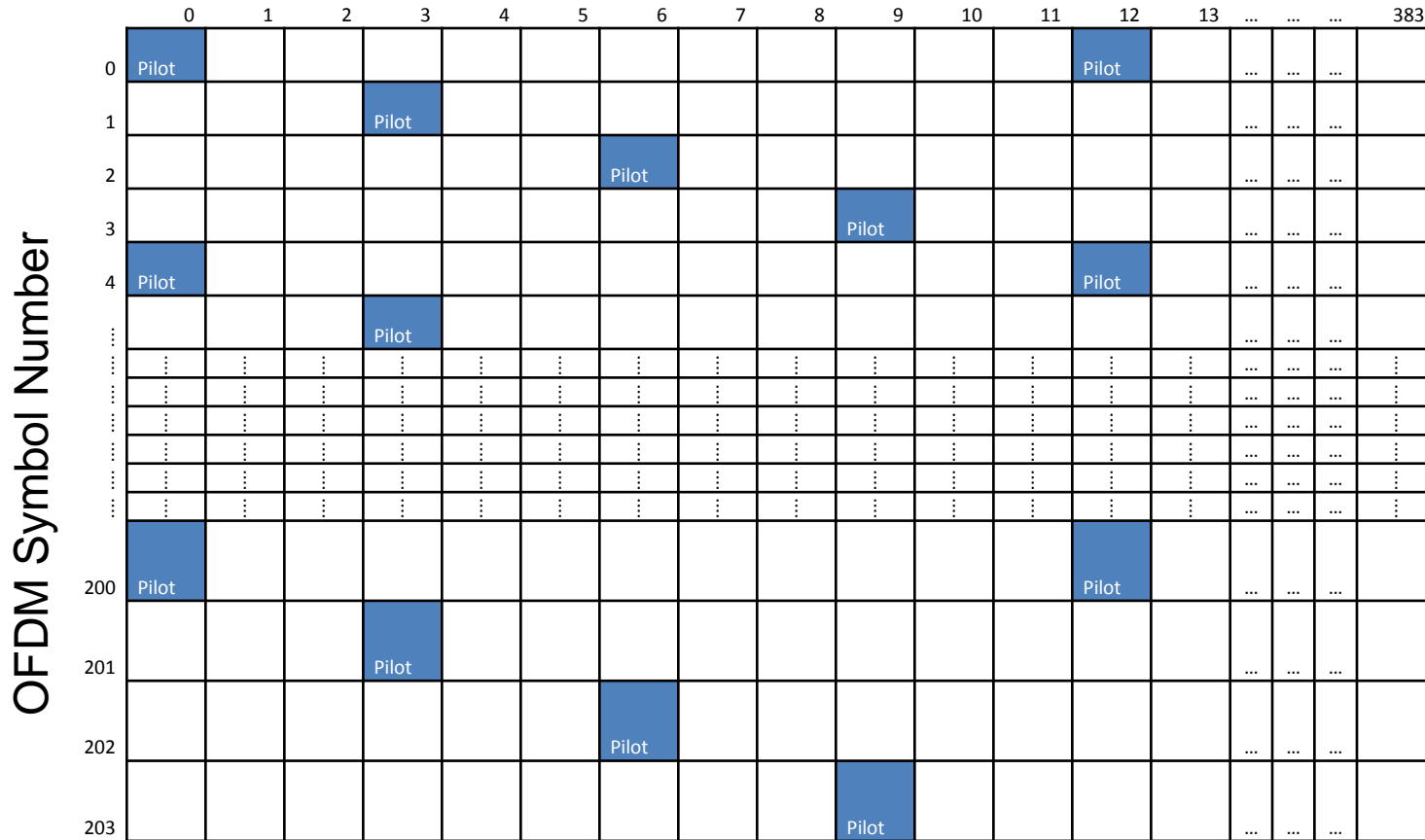

Frequency Interleaving of OFDM Modes #1 and #2

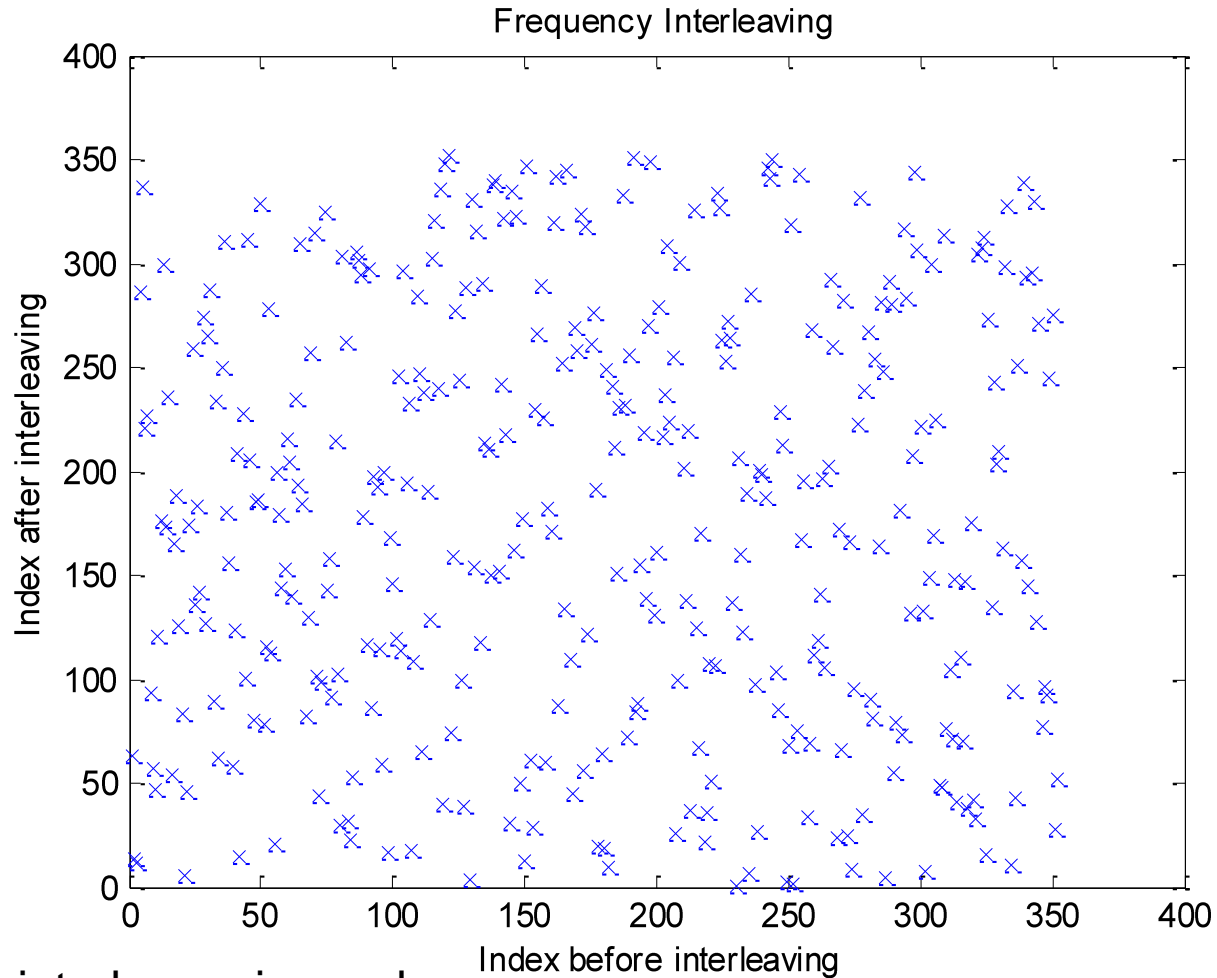

Random interleaver is used

Preamble of OFDM Modes #1 and #2

-STF and LTF proposed- (1/2)

- Sequence used: Zadoff-chu sequence
 - The sequence having ideal auto-correlation function
- 4 short training sequences of length 96 in each and 2 long training sequences of length 192 in each
 - 384 effective subcarriers in frequency domain
 - Realizing ideal auto-correlation property for ease in carrier offset estimation in frequency domain
 - The STF and LTF sequence having constant magnitude in both time and frequency domain

Preamble of OFDM Modes #1 and #2

-STF and LTF proposed- (2/2)

- Preamble consisting of 4 STFs and 2 LTFs both of which based on Zadoff Chu sequence

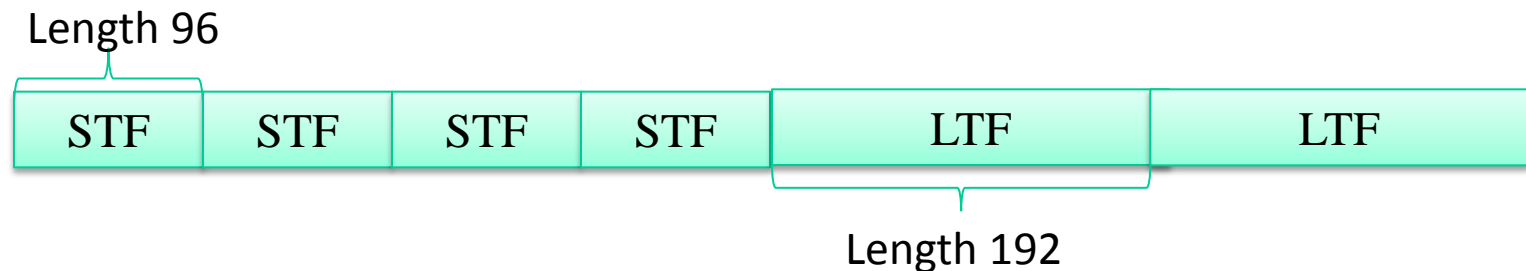

STF: Generated based on Zadoff Chu Sequence with length $N=96$,
 H is a prime number, for example, $H=19$,
sequence $a=(\exp(j \cdot H \cdot \pi \cdot k \cdot k / N))$;

LTF: Generated based on Zadoff Chu Sequence with length $N=192$,
 H is a prime number, for example, $H=53$,
sequence $a=\exp(j \cdot H \cdot \pi \cdot k^2 / N)$;

Data Rates Supported on OFDM Modes from #3 to #6

- Follow TG4g MR-OFDM Options for the PSD limits satisfaction
- Additional data rates modes proposed as follows

| Parameter | Modulation | CC coding rate | Freq. Repetition | Mode #3 | Mode #4 | Mode #5 | Mode #6 |
|-----------|------------|----------------|------------------|---------|---------|---------|---------|
| MCS0 | BPSK | 1/2 | 4 | 100 | 50 | - | - |
| MCS1 | BPSK | 1/2 | 2 | 200 | 100 | 50 | - |
| MCS2 | QPSK | 1/2 | 2 | 400 | 200 | 100 | 50 |
| MCS3 | QPSK | 1/2 | N/A | 800 | 400 | 200 | 100 |
| MCS4 | QPSK | 3/4 | N/A | 1200 | 600 | 300 | 150 |
| MCS5 | 16-QAM | 1/2 | N/A | 1600 | 800 | 400 | 200 |
| MCS6 | 16-QAM | 3/4 | N/A | 2400 | 1200 | 600 | 300 |

Channel Plan

Channel plan summary

- For FSK PHY with 6MHz bandwidth, there are 3 modes. 29 channels with 200kHz channel spacing; 14 channels with 400kHz channel spacing
- For OFDM PHY mode #1 with 6MHz bandwidth, 11 channels are allocated with channel spacing 400kHz, each side of 6MHz TV channel required a guard band of 800kHz
- For OFDM PHY # 2 with 8MHz bandwidth, 16 channels are divided with channel spacing 400kHz. Each side of 8MHz TV channel required a guard band of 800kHz.

Channel Centre Frequency

- The channel centre frequency can be derived based on the formulas below
- For FSK: $ChanCenterFreq = ChanFreq0 + (NumChan-1) * ChanSpacing$
- For OFDM (1.2MHz channel spacing to be included)

$$ChanCenterFreq = ChanFreq0 + \text{floor}(NumChan/11) + \text{mod}(NumChan-1, 11) * ChanSpacing \text{ (6MHz TV Band)}$$

$$ChanCenterFreq = ChanFreq0 + \text{floor}(NumChan/16) + \text{mod}(NumChan-1, 16) * ChanSpacing \text{ (8MHz TV Band)}$$

- Where $ChanCenterFreq$ is channel centre frequency
- $ChanFreq0$ is the starting channel centre frequency of every continuously available TV channel
- $NumChan$ is the index of channel in every continuously available TV channel
- $TotalNumChan$ is total number of channel in every continuously available TV Channel band
- $ChanSpacing$ is channel spacing

Total number of channels and first channel centre frequencies for proposed PHYs

| Freq. band (MHz) | Modulation | ChanSpacing(MHz) | TotalNumChan | ChanFreq0 |
|------------------|------------------------|------------------|--------------|-----------|
| 54-60 | Filtered 2FSK | 0.2 | 29 | 54.2 |
| | Filtered 2FSK | 0.4 | 14 | 54.4 |
| | Filtered 2FSK and 4FSK | 0.6 | 9 | 54.6 |
| | OFDM | 0.4 | 11 | 55 |
| 76-88 | Filtered 2FSK | 0.2 | 58 | 76.2 |
| | Filtered 2FSK | 0.4 | 28 | 76.4 |
| | Filtered 2FSK and 4FSK | 0.6 | 18 | 76.6 |
| | OFDM | 0.4 | 22 | 77 |
| 174-216 | Filtered 2FSK | 0.2 | 203 | 174.2 |
| | Filtered 2FSK | 0.4 | 98 | 174.4 |
| | Filtered 2FSK and 4FSK | 0.6 | 63 | 174.6 |
| | OFDM | 0.4 | 77 | 175 |
| 470-602 | Filtered 2FSK | 0.2 | 638 | 470.2 |
| | Filtered 2FSK | 0.4 | 308 | 470.4 |
| | Filtered 2FSK and 4FSK | 0.6 | 198 | 470.6 |
| | OFDM | 0.4 | 242 | 471 |
| 620-698 | Filtered 2FSK | 0.2 | 377 | 620.2 |
| | Filtered 2FSK | 0.4 | 182 | 620.4 |
| | Filtered 2FSK and 4FSK | 0.6 | 117 | 620.6 |
| | OFDM | 0.4 | 143 | 621 |

(based on FCC available TV Channel Table)

Channel Aggregation proposed for OFDM mode #1 and #2

For fixed device, more than one, up to 11 subchannels can be aggregated and form one channel in a 6MHz Band to support data rate of more than 10Mbps.

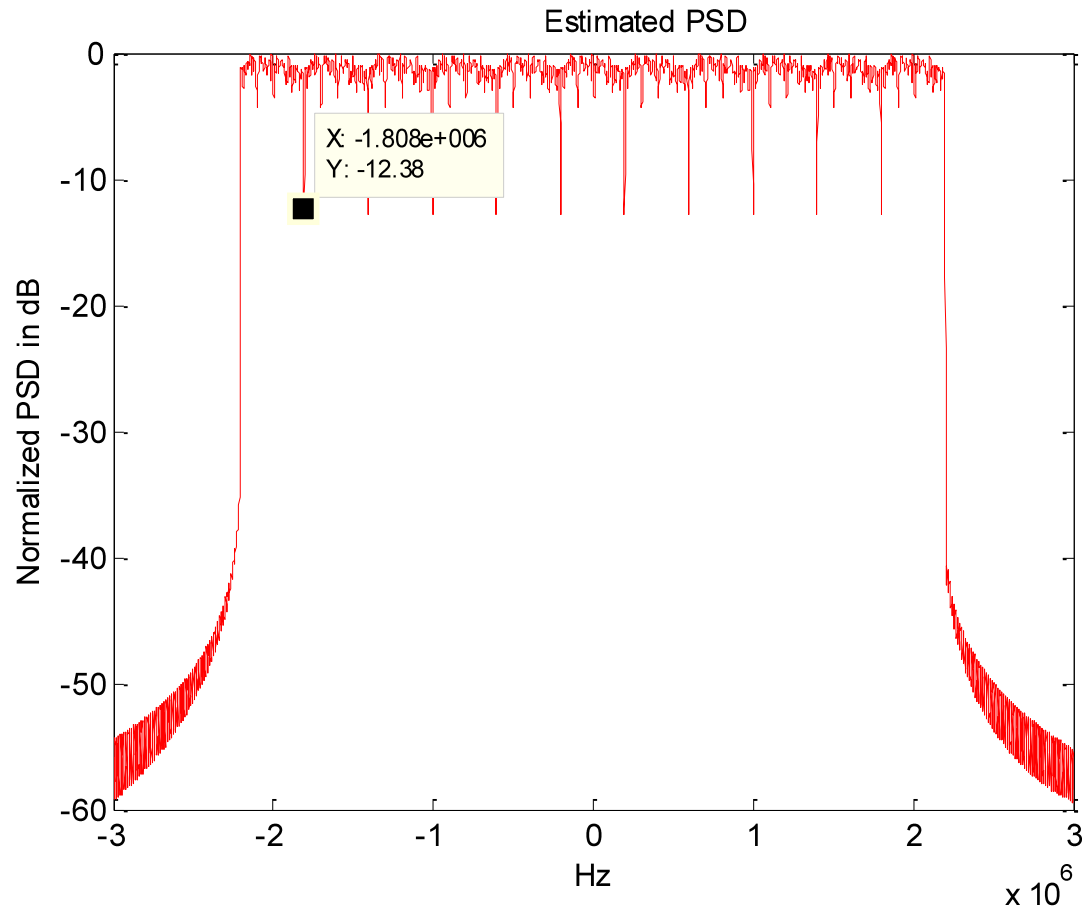

Conclusions of PHY proposal

- FSK PHY
 - Based on TG4g FSK PHY, concatenated code of RS and systematic CC with interleaver proposed for the lowest data rate mode for wider coverage area
- OFDM PHY
 - Two plus Four OFDM PHY modes proposed as options
 - Two modes based on one-segment broadcasting system to achieve increased flexibility and efficiency of channels
 - System parameters, FEC, bit and frequency interleavers, MCS, and preamble
 - Channel aggregation
 - TG4g MR-OFDM based system proposed
- Channel Plan
 - On a consideration of usage on 6 MHz and 8 MHz bandwidth under FCC regulatory limits, channel centre frequency and guard bandwidth proposed

MAC PROPOSAL

Executive Outline - MAC

- Proposal
 - TVWS Operation Enabling Protocol
 - Dynamic Band Switching
 - Power Saving Mechanism
 - Direct Device-to-device Data Transfer
- Expected expansion/coexistence
 - TVWS Multi-Channel Utilization (TMCU)
 - Spectrum Management
 - Ranging

Summary of MAC Proposal From NICT

- TVWS Operation Enabling Protocol
- Dynamic Band Switching
- Power Saving Mechanism
- Direct Device-to-device Data Transfer

TVWS Operation Enabling Protocol

Summary

- This document proposes an enabling protocol for IEEE 802.15.4 WPAN operating in TVWS, meeting the requirement by TVWS regulations
- What was concluded in our presentation in 2012 May Atlanta meeting, doc.12/222r0:
 - IEEE 802.15.4 network architecture is able to comply with the architecture required by TVWS regulations
 - IEEE 802.15.4 device type is able to fit into the categorization required by TVWS regulations
 - IEEE 802.15.4 functionalities is able to perform the enabling protocol with minor modification
- This document presents the details of the enabling protocol
 - Required protocol
 - Addition of IE
 - Modification of service primitives

Outline

- Summary of Major Regulatory Bodies
- Application-802.15.4-Regulation Mapping
- General State Transition Diagram
- Operational Procedure
- Detailed State Transition Diagram – Master
- Detailed State Transition Diagram – Slave
- Message Sequence Chart
- Frame Format
- Service Primitives

Summary of Major Regulatory Bodies

| Regulatory Domains | FCC, USA | OFCOM, UK | Industry Canada, Canada | CEPT ECC, Europe |
|------------------------------|--|---|--|---|
| TV Channel-ization | 6 MHz | 8 MHz | 6 MHz | 8 MHz |
| Available TV Channels | Ch2 to Ch4: 54 to 72 MHz Ch5 to Ch6: 76 to 88 MHz Ch7 to Ch13: 174 to 216 MHz Ch14 to Ch51: 470 to 698 MHz | Ch21 to Ch60: 470 and 790 MHz | Ch2 to Ch4: 54 to 72 MHz Ch5 to Ch6: 76 to 88 MHz Ch7 to Ch13: 174 to 216 MHz Ch14 to Ch51: 470 to 698 MHz | 470 to 790 MHz |
| Device Type | Fixed device (FD) Personal/portable device (PPD) Mode II PPD Mode I PPD Sensing-only device (SOD) | Master device (MD) Slave device (SD) | Fixed WSD (FWSD) Mobile WSD (MWSD) Mode II MWSD Mode I | Master device (MD) Slave device (SD) |
| TX Power | FD: 4W PPD: 100mW PPD SOD: 50mW FD disallowed in first adjacent channel PPD: 40mW (adj. channel) | DB informs the allowable transmit power | FWSD: 4W MWSD: 100mW MWSD: 40mW (adj. channel) | DB informs the allowable transmit power |
| Access Rules | FD: Ch2, Ch5 to Ch35, Ch39 to Ch51 PPD: Ch21 to Ch35, Ch39 to Ch51 | MD and SD: Ch21 to Ch30 and Ch39 to Ch60 | FWSD and MWSD: Ch2 to Ch36 and Ch38 to Ch51 | – |
| DB Access | FD: once/day PPD Mode II: once/day, every 100m relocation PPD Mode I: not required PPD SOD: not required PPD Mode II may access DB via other PPD Mode II | MD: required SD: not required DB informs available channels and information time validity | MWSD: required FWSD: required FWSD Mode II may access DB via other FWSD Mode II | DB informs available channels and information time validity |
| Geo-location | FD: accuracy 50m PPD Mode II: accuracy 50m, re-establish location every 60s PPD Mode I: not required PPD SOD: not required | MD: accuracy 100m SD: not required | MWSD: required FWSD Mode II: required FWSD Mode I: not required | MD: required SD: not required |
| Spectrum Sensing | PPD SOD: required | DB informs whether sensing is required | – | DB informs whether sensing is required |
| Additional Notes | Contact Verification Signal required by PPD Mode I every 60s | – | The channels bands are currently being shared with low power apparatus (LPA) and remote rural broadband systems (RRBS) | – |

Application-802.15.4-Regulation Mapping

| Application | IEEE 802.15.4 Device Type | TVBD Classes | Sensing Capability | Geo-location Awareness | Maximum Transmit Power |
|-------------------------------|---------------------------|----------------------------|--------------------|------------------------|------------------------|
| Utility provider base station | FFD | Fixed device | Not required | Required | 4 W |
| Data collector | FFD | Mode II independent device | Not required | Required | 100 mW |
| Electric/gas/water meter | FFD/RFD | Mode II independent device | Not required | Required | 100 mW |
| | | Mode I client device | Not required | Not required | 100 mW |
| Mobile data collector | FFD/RFD | Mode II independent device | Not required | Required | 100 mW |
| | | Sensing-only device | Required | Not required | 50 mW |

Note: This table is only an example to illustrate the mapping relationship among SUN application, 802.15.4 network and FCC requirement. Applications other than SUN and regulations other than FCC may also go through the same mapping process with IEEE 802.15.4 system

General State Transition Diagram

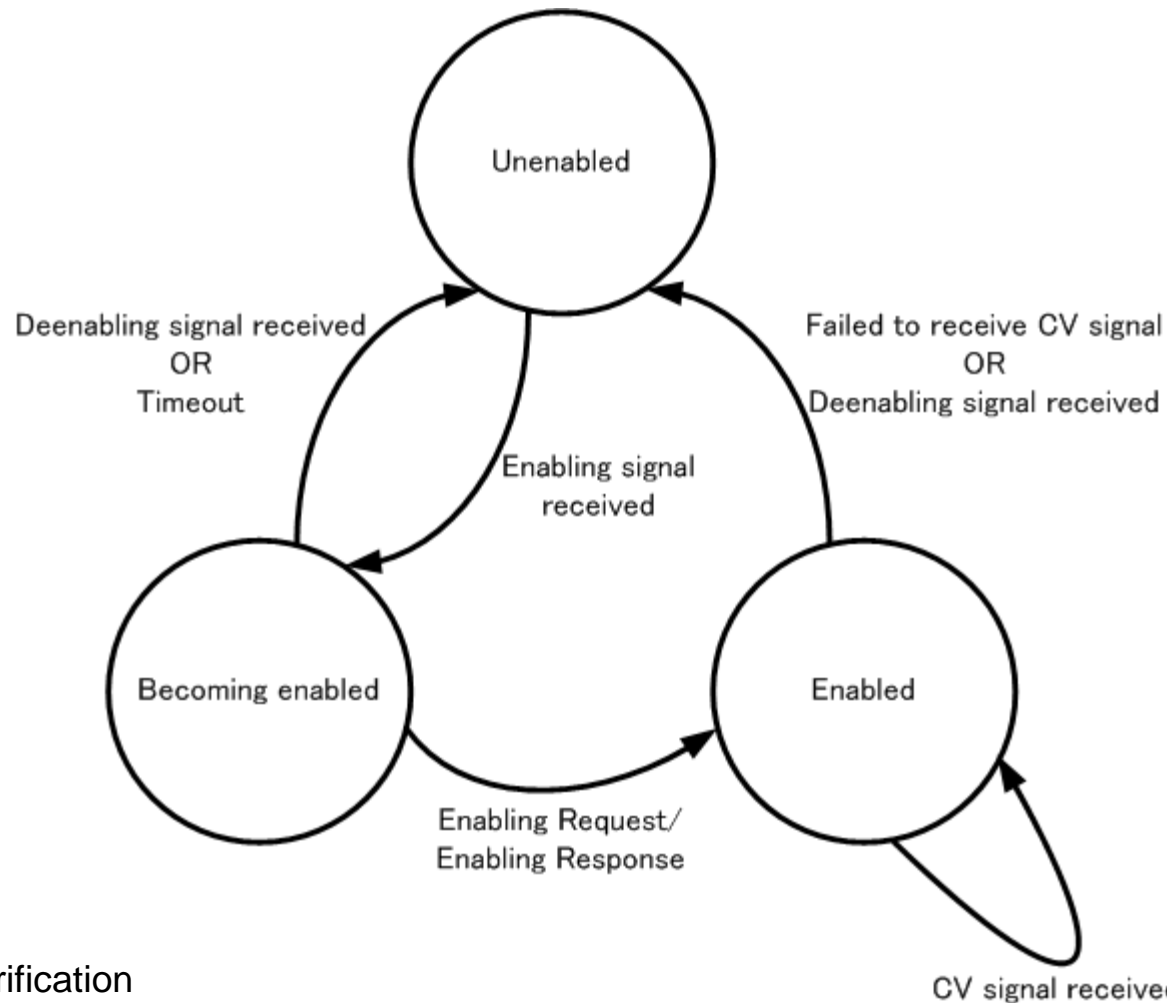

CV: contact verification

Operational Procedure

- Fixed and Mode independent II devices (*i.e.* 802.15.4m FFD, master device) obtain the list of available TV channels from the GDB through the internet
- Then, the TV channels are mapped to corresponding WPAN channels
- Next, the fixed and Mode II devices transmit the enabling signal in the channel of interest to surrounding devices attempting to join the network
- Upon receiving the enabling signal, the Mode client I devices (*i.e.* 802.15.4m RFD, slave device) are to provide information for verification
- After verification, the fixed and Mode II devices send the WPAN channel list to the Mode I devices
- Besides the list of WPAN channels, the signal may also contain other information such as timing schedule for the occupancy of the channel and nearby locations where the channels are available
- Upon receiving the channel list, Mode I devices are then able to transmit signal in the specific channel(s) of interest
- Additionally, a periodic contact verification signal is required to constantly update the status of enablement
- For both the enabling signal and contact verification signals, the 802.15.4 beacon frame or enhanced beacon frame can be reused with additional IEs
- For the verification signaling handshake, the 802.15.4 command frames can be reused with additional IEs

Detailed State Transition Diagram

~ Master Device ~

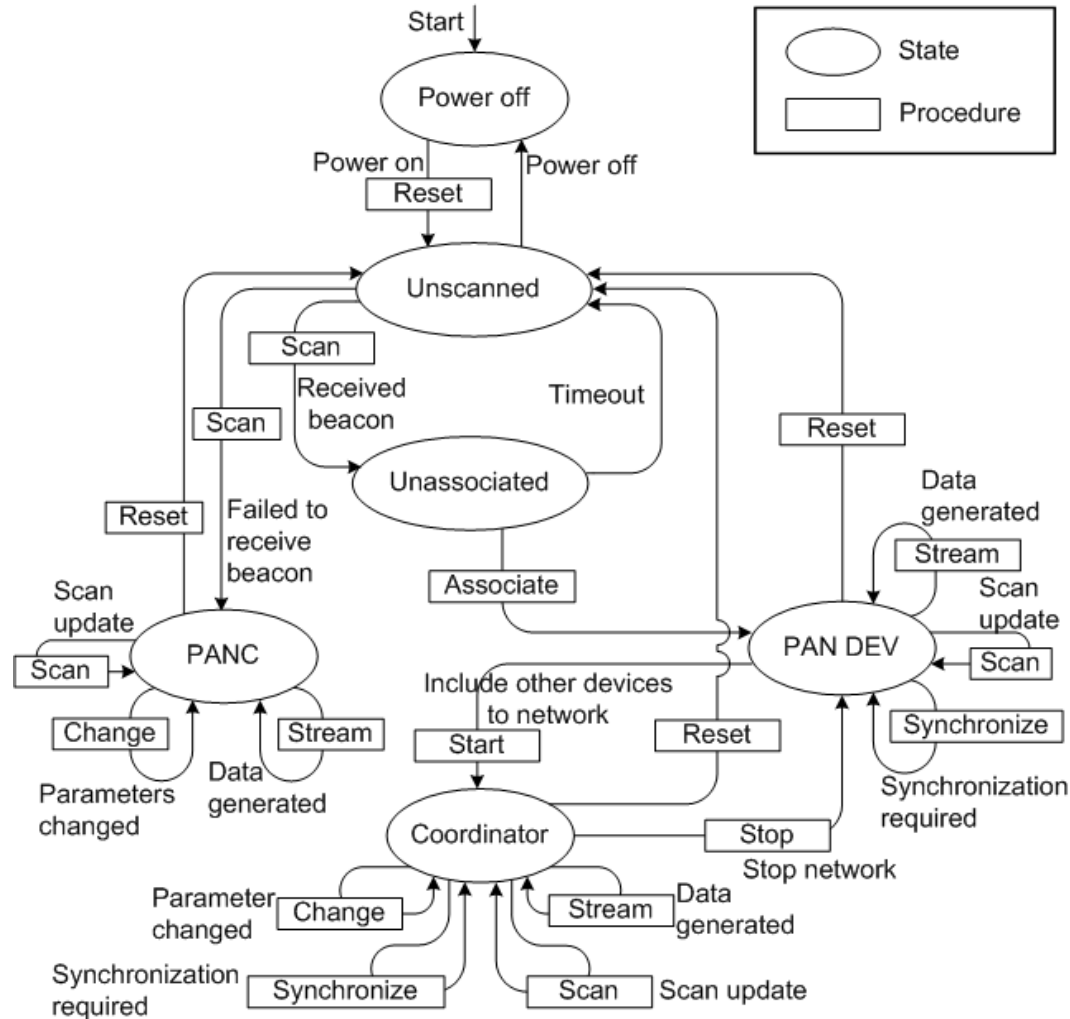

Detailed State Transition Diagram

~ Slave Device ~

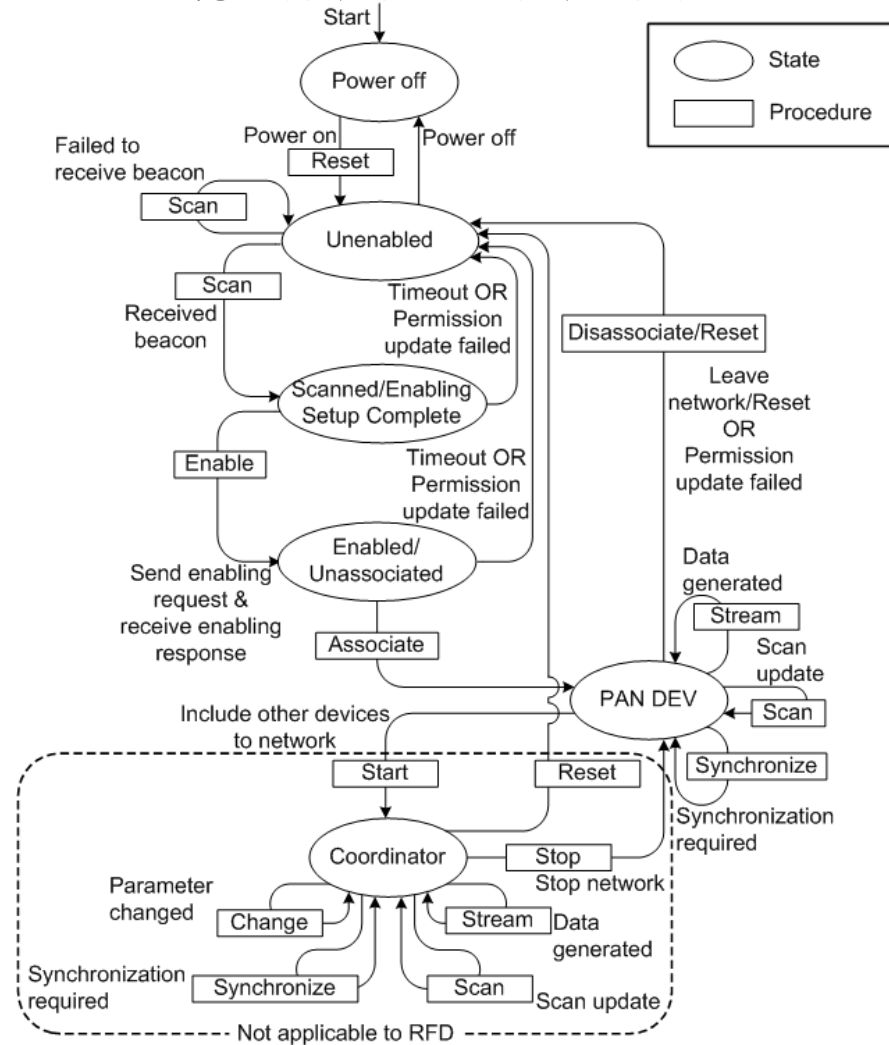

Message Sequence Chart

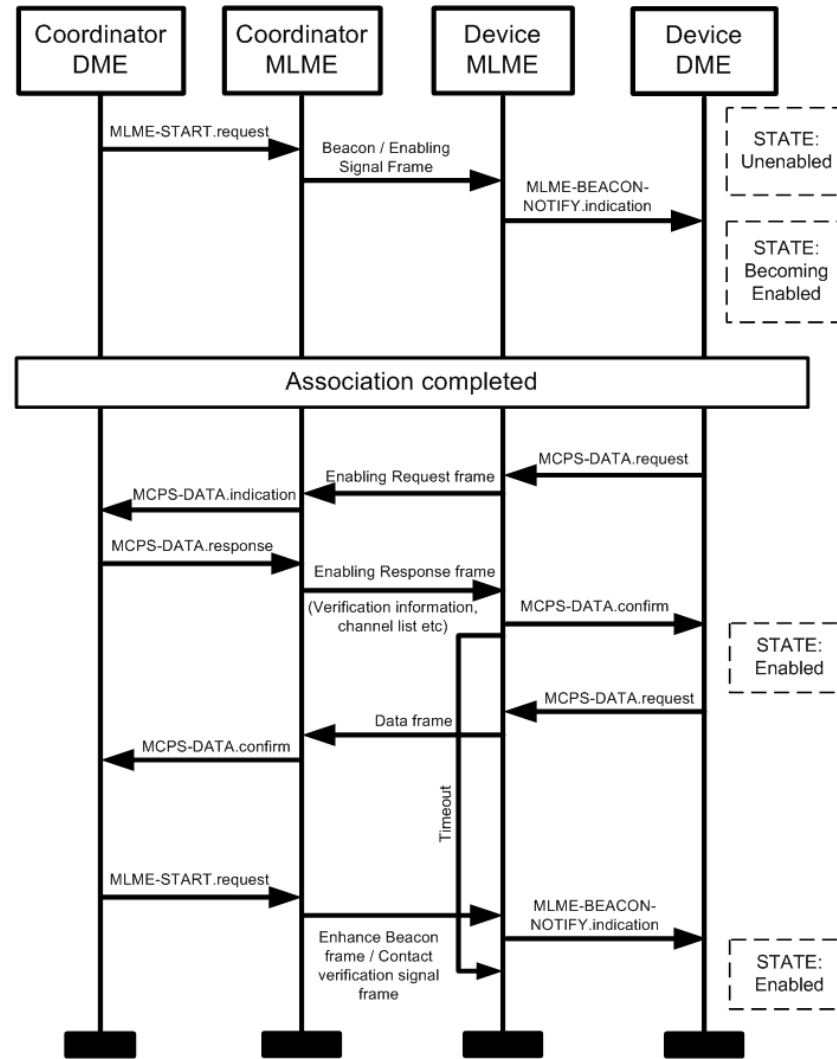

Frame Format

- Enabling signal frame
 - Reuse IEEE 802.15.4 beacon frame format
 - Reuse the name of the frame with additional IE
 - Include information on regulation and operating channel
- Enabling Request and Response Frame
 - Reuse IEEE 802.15.4 command frame format
 - Reuse the name of the frame with additional IE
 - Include information on verification information, list of vacant WPAN channels, timing schedule for the vacancy, information on vacancy for the channels in nearby locations
- Contact Verification Signal frame
 - Reuse IEEE 802.15.4e enhanced beacon frame format
 - Reuse the name of the frame with additional IE
 - Update on enablement status

Frame Format

~ IE for Enabling signal ~

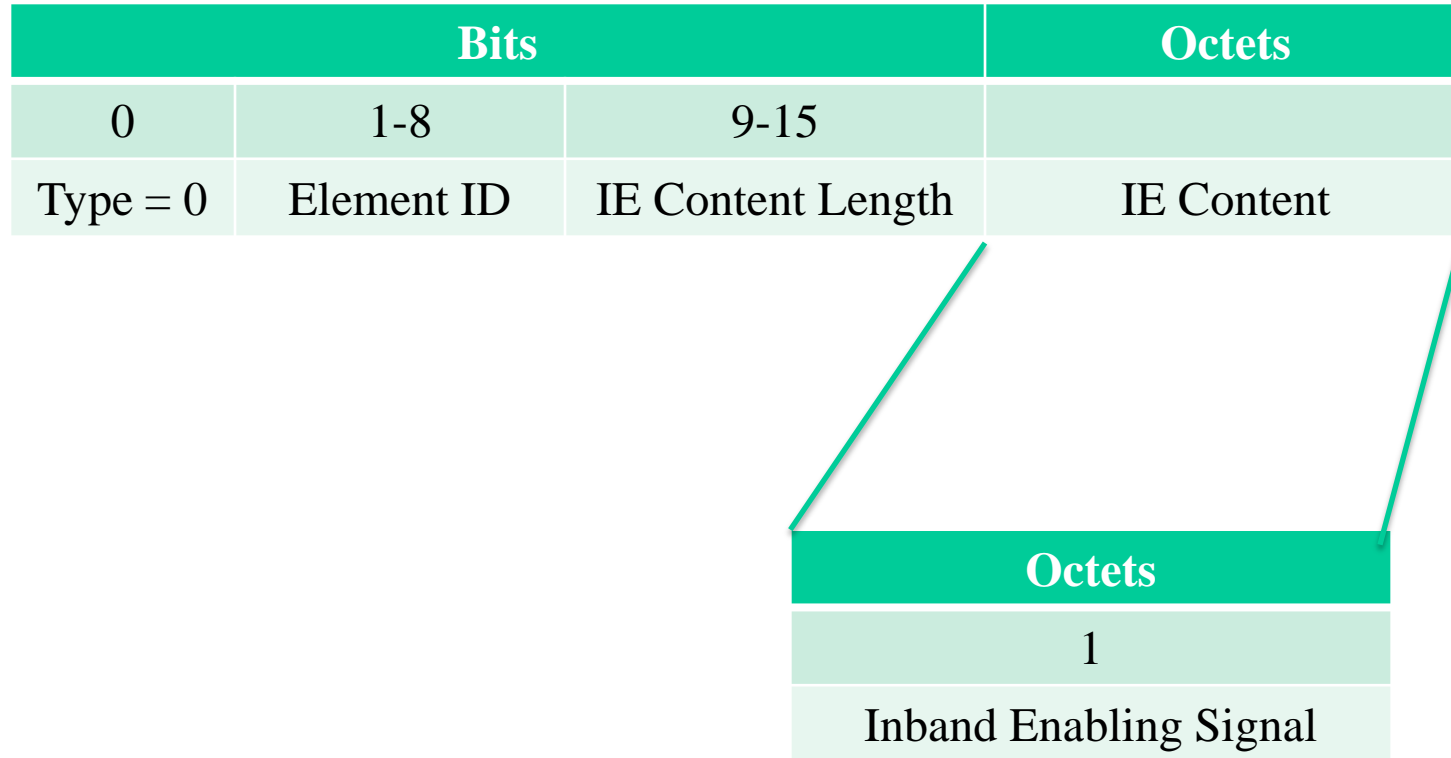

Frame Format

~ IE for Enabling Request and Response~

| Bits | | | Octets |
|----------|------------|-------------------|------------|
| 0 | 1-8 | 9-15 | |
| Type = 0 | Element ID | IE Content Length | IE Content |

| Octets | | | | |
|--------------------|--------------|-----------------------|-----------------|------------------|
| 1 | 1 | variable | variable | variable |
| Channel Query Info | Device Class | Device Identification | Device Location | White Space Info |

Frame Format

~ IE for Contact Verification Signal ~

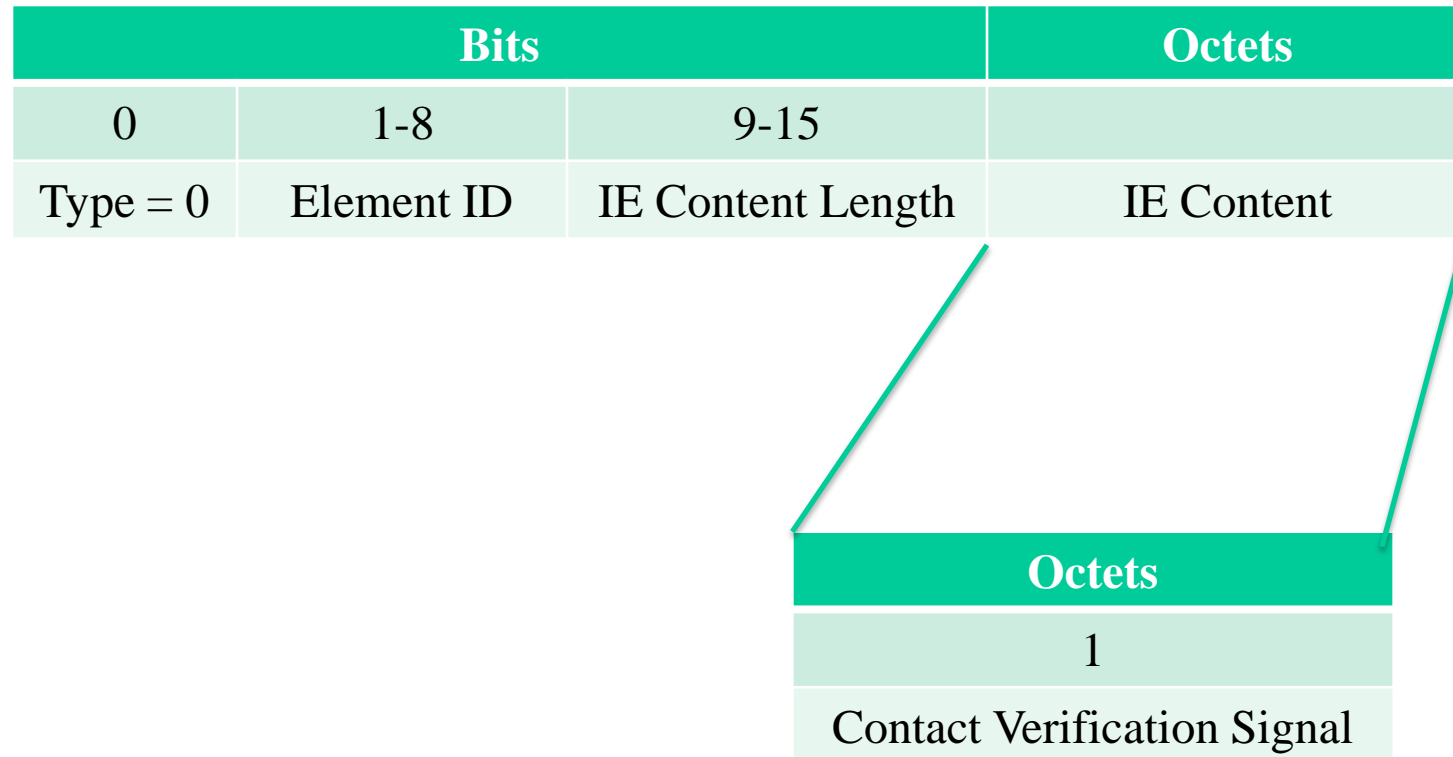

Service Primitives

- Primitives between DME and MLME of initiator and responder devices on Enabling Signal and Contact Verification Signal frames
 - MLME-START.request
 - MLME-START.indication
 - MLME-ENABLING.request
 - MLME-ENALBLING.response
 - MLME-ENALBLING.indication
 - MLME-ENALBLING.confirm
 - MLME-CVS.request
 - MLME-CVS.response
 - MLME-CVS.indication

Dynamic Band Switching

Summary

- This document proposes a Dynamic Band Switching (DBS) protocol to facilitate frequency band switching for IEEE 802.15.4 low rate WPAN systems
- What was concluded in our presentation in 2012 May Atlanta meeting, doc.12/222r0:
 - Capability to switch between different regulatory bands, particularly TVWS and other conventional IEEE 802.15.4 bands is beneficial
- This document presents the details of the DBS protocol
 - Required protocol
 - Addition of IE
 - Modification of service primitives

Outline

- Introduction
- State Transition Diagram
- State Description
- Operational Procedure
- Message Sequence Chart
- Frame Format
- Service Primitives

Introduction

- Dynamic band switching (DBS) is a protocol facilitating switching between operating frequency bands
- There are many regulatory-domain specific frequency bands applicable only in certain locations
- Currently existing frequency bands that could be included into the DBS mechanism
 - TVWS frequency bands
 - SUN frequency band specified in IEEE 802.15.4g
 - Other IEEE 802.15.4 conventional frequency bands

State Transition Diagram

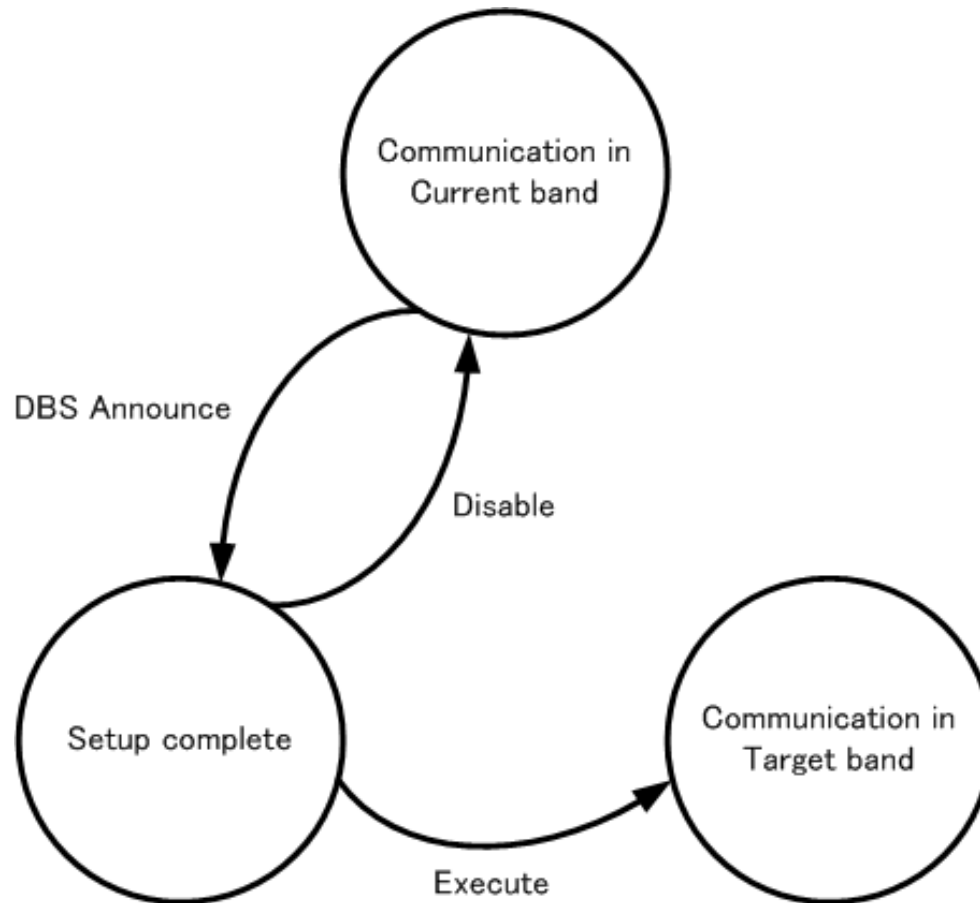

State Description

- Communication in Current Band:
 - Data communication in current (old) frequency band
 - Initiator (normally the coordinator) announces the intention to switch frequency band
 - Enhanced beacon with DBS IE is used to initiate state change
 - DBS IE consists of the time to commencement of band switching
- Setup Completed:
 - Running Timer for band switching
 - If initiator decides to disable the band switching, Enhanced beacon with DBS IE is sent
- Communication in Targeted Band:
 - Data communication in target (new) frequency band

Operational Procedure

- To start DBS, the capability of frequency bands and channels are exchanged between devices in the network
 - In the case where the enhanced beacon with DBS IE is broadcasted, there will be no capability inquiry and response between devices
- The requester sends out the enhanced beacon with DBS IE containing all information needed to perform band switching, including the time for all the devices to commence the band switching
- When the Execute time scheduled by the requester arrives, the operating band of both the requester and responder will be switched to the new band parameters
- During the period of Execute time waiting, if the requester decides to cancel DBS, Enhanced beacon with DBS IE can be used to cancel the operation

Message Sequence Chart

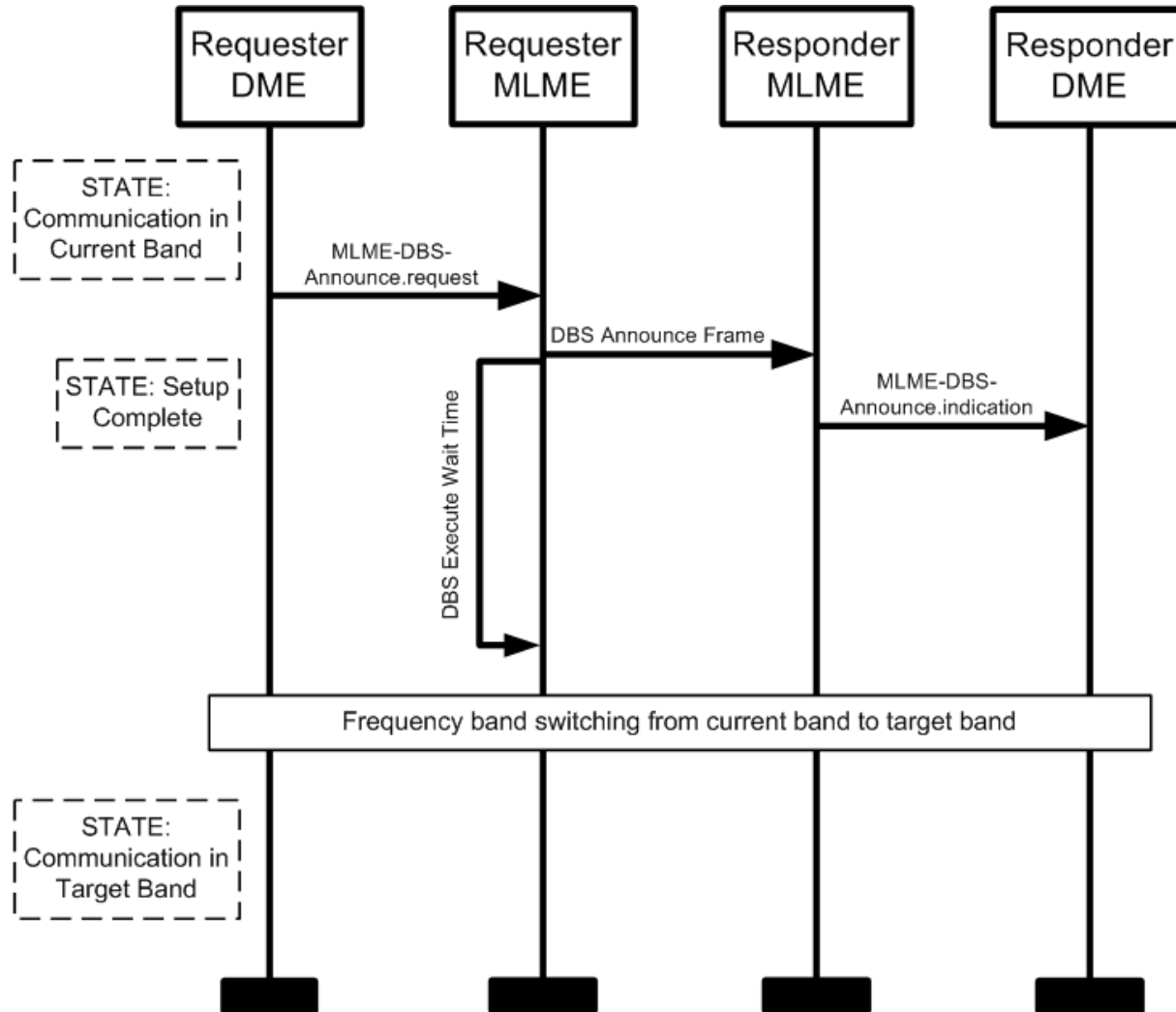

Frame Format

~ DBS IE ~

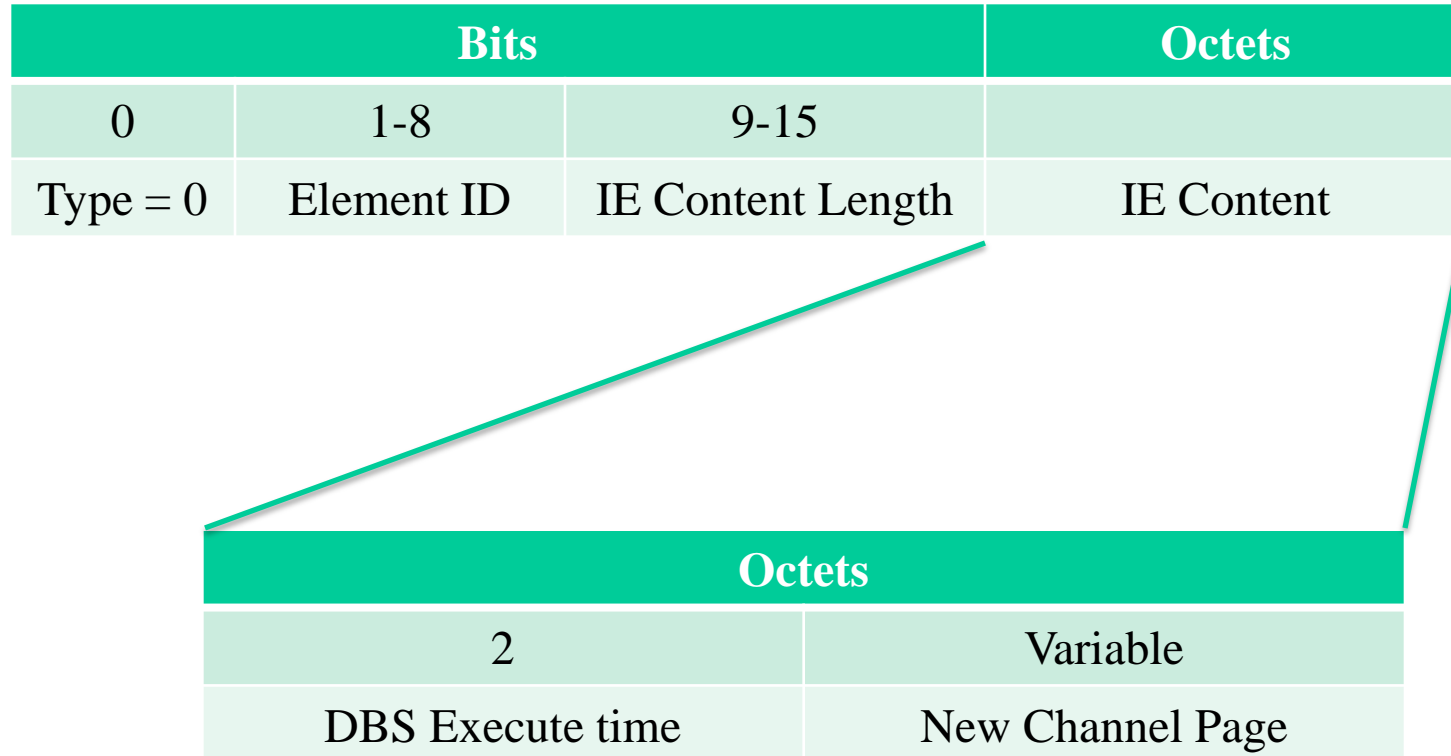

Frame Format

~ DBS IE ~

- To exchange DBS capability
 - Set New Channel Page to the band and channel of interest
 - Set Execute Time to all one
- To announce the DBS intention
 - Set New Channel Page to the targeted band and channel
 - Set Execute Time to the intended time to commence switching
- To cancel the DBS intention
 - Set New Channel Page to the current (old) band and channel
 - Set Execute Time to all zero

Service Primitives

- Primitives between DME and MLME for enhanced beacon with a DBS IE
 - MLME-BEACON.request
 - MLME-BEACON.confirm
- New parameters to be added to the DBS IE
 - DBS Execute Time

Power Saving Mechanism

Summary

- This document proposes a power saving mechanism for IEEE 802.15.4 low rate WPAN systems
- What was concluded in our presentation in 2012 May Atlanta meeting, doc.12/222r0:
 - For most LR-WPAN applications, power saving mechanism to enable long battery lifespan of devices is important
- This document presents the details of the power saving mechanism
 - Required protocol
 - Addition of IE
 - Modification of service primitives

Illustration of Procedure

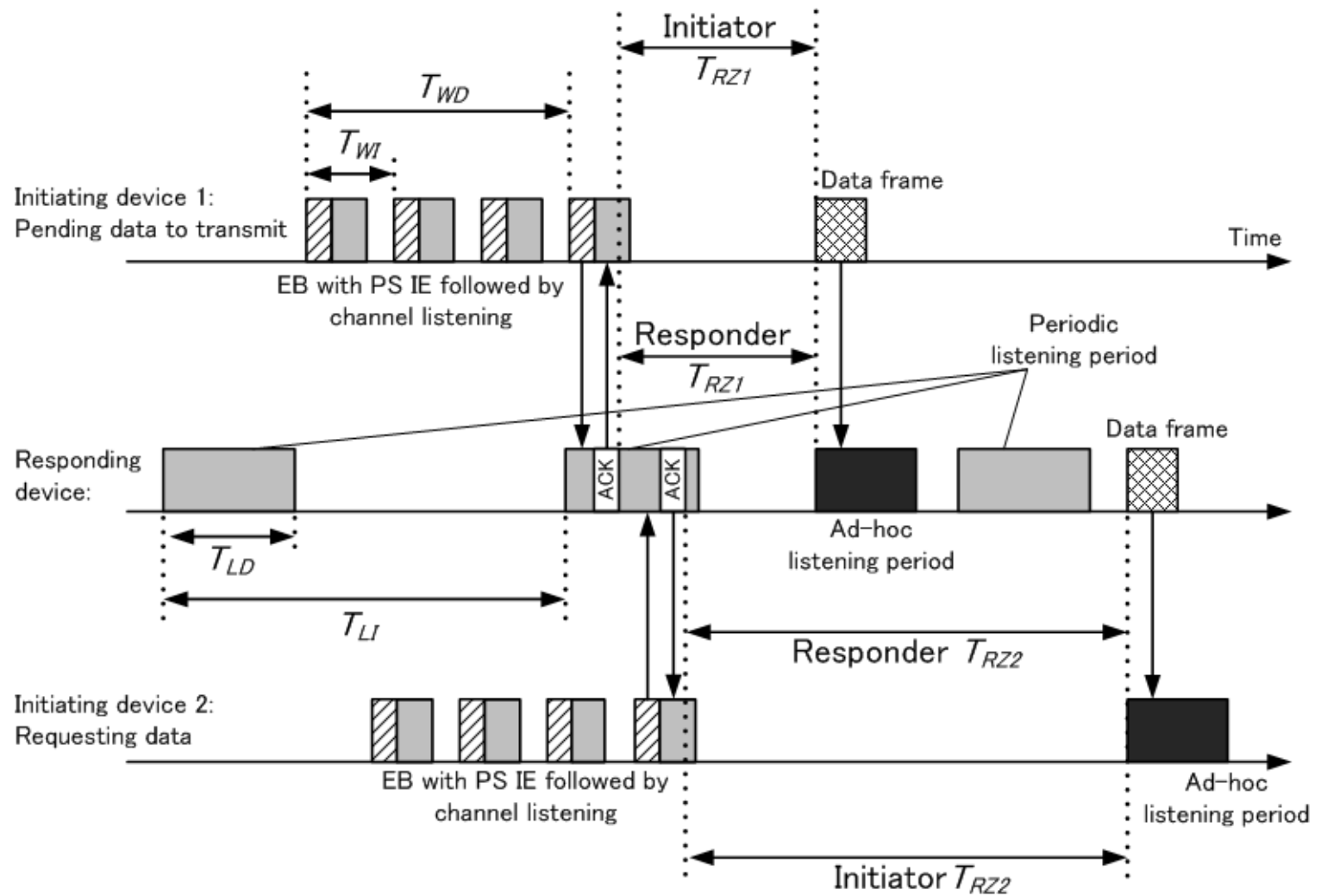

Operational Procedure

- The responding device switches on the periodic listening periods T_{LI} apart each with duration T_{LD}
 - The responding device may announce its T_{LI} and T_{LD}
- The initiating device transmits multiple enhanced beacon frames with PS IE (followed by channel listening), T_{WI} apart for maximum total duration T_{WD} (or upon receiving an ACK, whichever occurs first)
 - It is recommended that $T_{WI} \leq T_{LD}$ and $T_{LI} \leq T_{WD}$
 - Upon receiving ACK from the responding device, transmission of enhanced beacon frames with PS IE will be stopped
- The PS IE contains information on:
 - Whether the initiating device is transmitting pending data (case 1) or requesting for data (case 2)
 - Timing information for rendezvous
- Upon receiving an enhanced beacon frames with PS IE, the responding device
 - Case 1: Switches on an ad-hoc listening period to receive the data from the initiating device at rendezvous time (the ad-hoc listening period can be set as the subsequent periodic listening period)
 - Case 2: Transmit the data requested by initiating device at rendezvous time
- Rendezvous time can be set by initiator and updated by responder

MSC for Case 1

~ Initiator with Pending Data ~

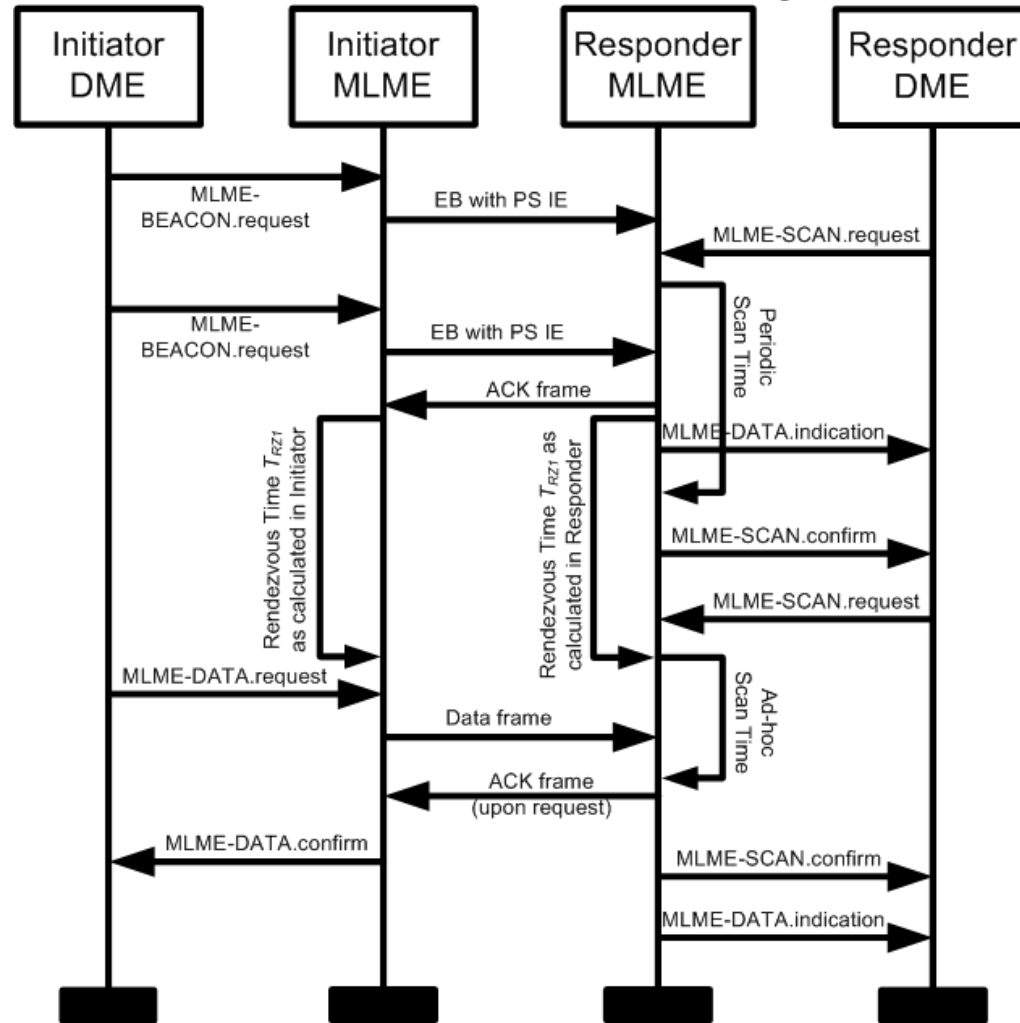

MSC for Case 2

~ Initiator with Data Request ~

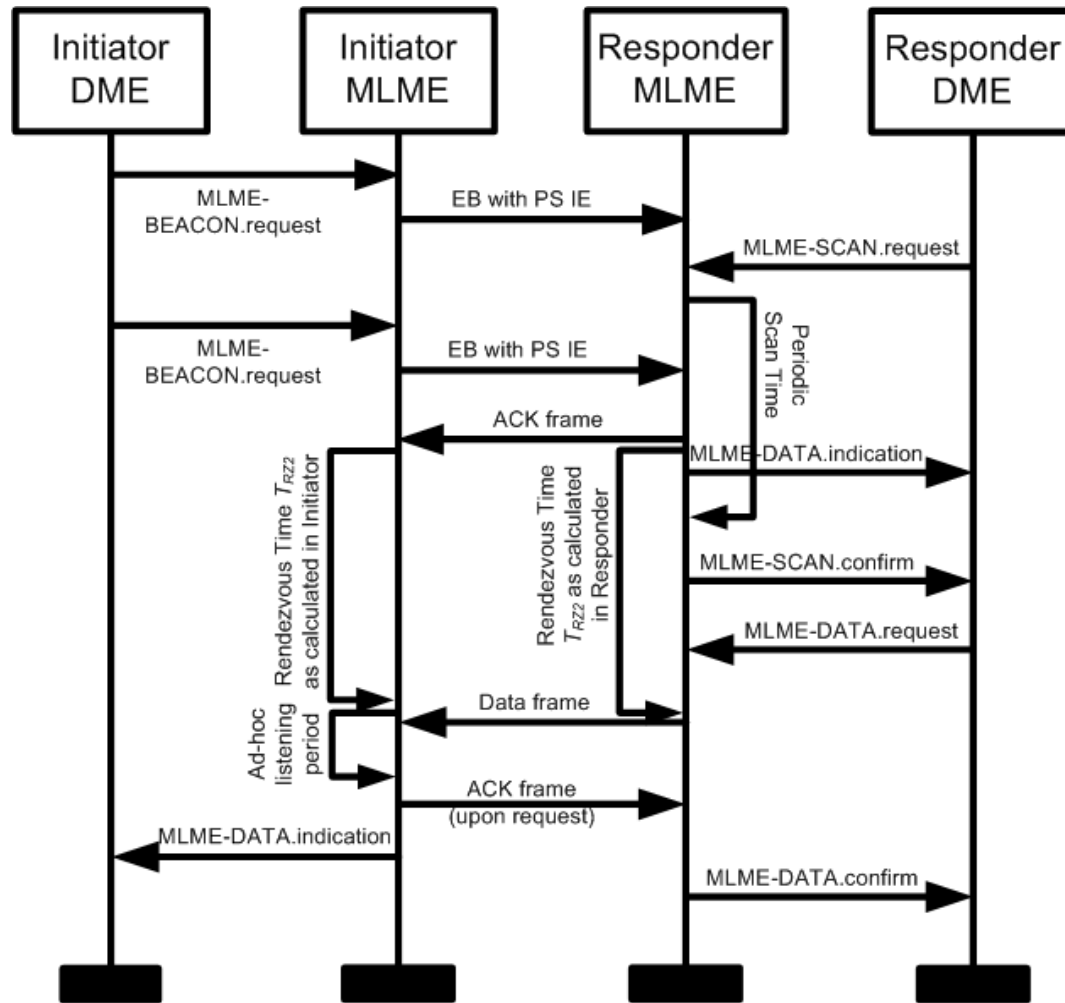

State Transition Diagram

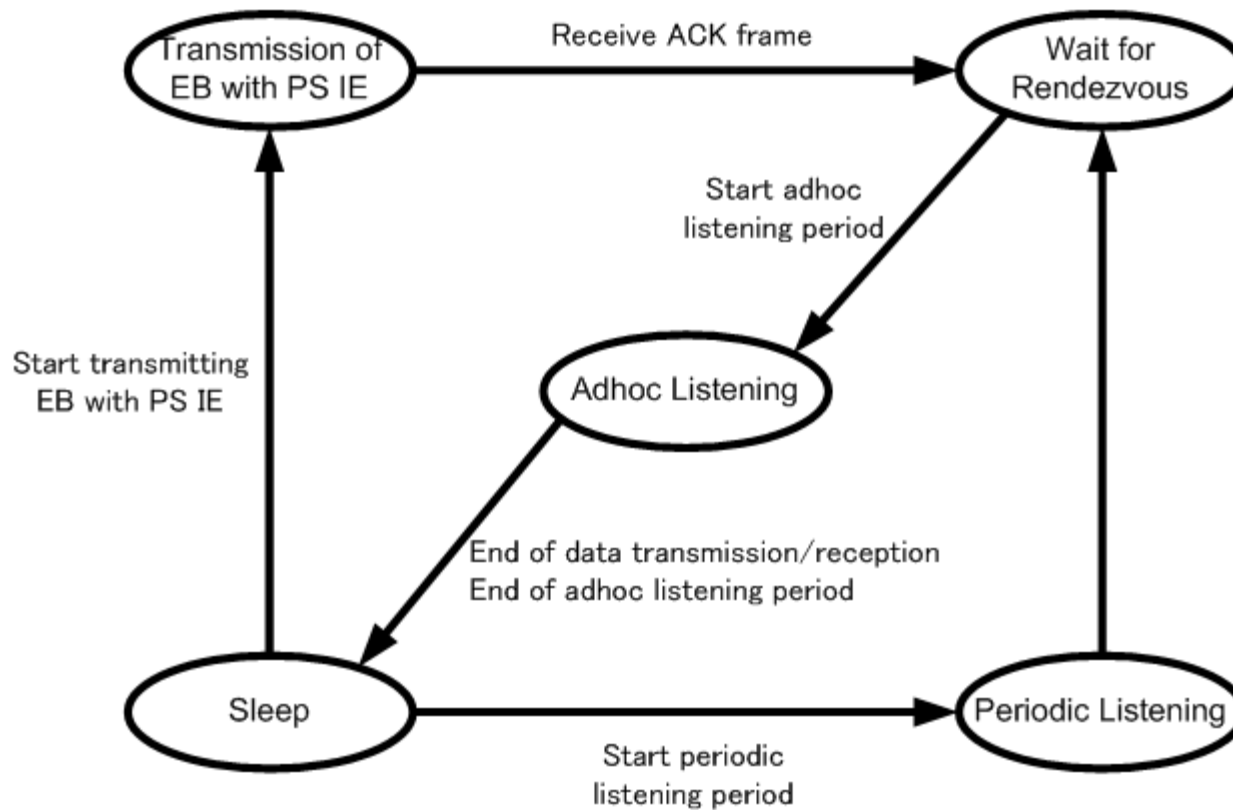

Frame Format

~PS IE~

| Bits | | | Octets | | | | |
|----------|------------|-------------------|------------|-----------------------------|-----------------------------|-----------------|-----------|
| 0 | 1-8 | 9-15 | 1 | 2 | 2 | 2 | 1 |
| Type = 0 | Element ID | IE Content Length | PS Control | Periodic Listening Interval | Periodic Listening Duration | Rendezvous Time | Data Size |

All three fields use the same bit allocation pattern

| Bits | Description |
|-------|--------------------------------|
| 0 | Pending data to transmit |
| 1 | Requesting data |
| 2 | Announce T_{LI} and T_{LD} |
| 3-255 | Reserved |

| Bits | Description |
|-------|-------------|
| 0 | 0 |
| 1 | 1ms |
| ... | ... |
| 65535 | 65535ms |

| Bits | Description |
|------|-------------|
| 0 | 0 |
| 1 | TBD |
| ... | ... |
| 255 | TBD |

Service Primitives

- Primitives between DME and MLME for enhanced beacon with a PS IE
 - MLME-BEACON.request
 - MLME-BEACON.confirm
- Primitives between DME and MLME of initiator and responder devices for periodic and ad-hoc scan
 - MLME-SCAN.request
 - MLME-SCAN.indication
- New parameters to be added to the DBS IE
 - PS control
 - Periodic listening period
 - Periodic listening interval
 - Rendezvous time
 - Data size

Direct Device-to-device Data Transfer

Summary

- This document proposes four modes of direct device-to-device data transfer in IEEE 802.15.4 WPAN, including neighbor discovery mechanism
- Main operation procedures as well as message sequence charts are presented with details

Outline

- Neighbor discovery mechanism and message sequence chart
- Mechanism of Probing-mode direct data transfer
- Mechanism of Polling-mode direct data transfer
- Mechanism of Broadcast-mode direct data transfer
- Mechanism of Multicast-mode direct data transfer

Neighbor Discovery

- What's a neighbor device?
 - In this standard, a neighbor device is a peer device that associates with the same coordinator
- Why a device need to discover neighbor device?
 - To enable direct device-to-device data transfer
- When can a device carry out neighbor discovery?
 - A device may carry out neighbor discovery after association with its coordinator, at appropriate time when receives the MLME-NBR.Request primitive from the next higher layer.
 - On beacon-enabled PAN, a coordinator shall carry out neighbor discovery in the active portion of its incoming superframe.

Message Sequence Chart for Neighbor Discovery

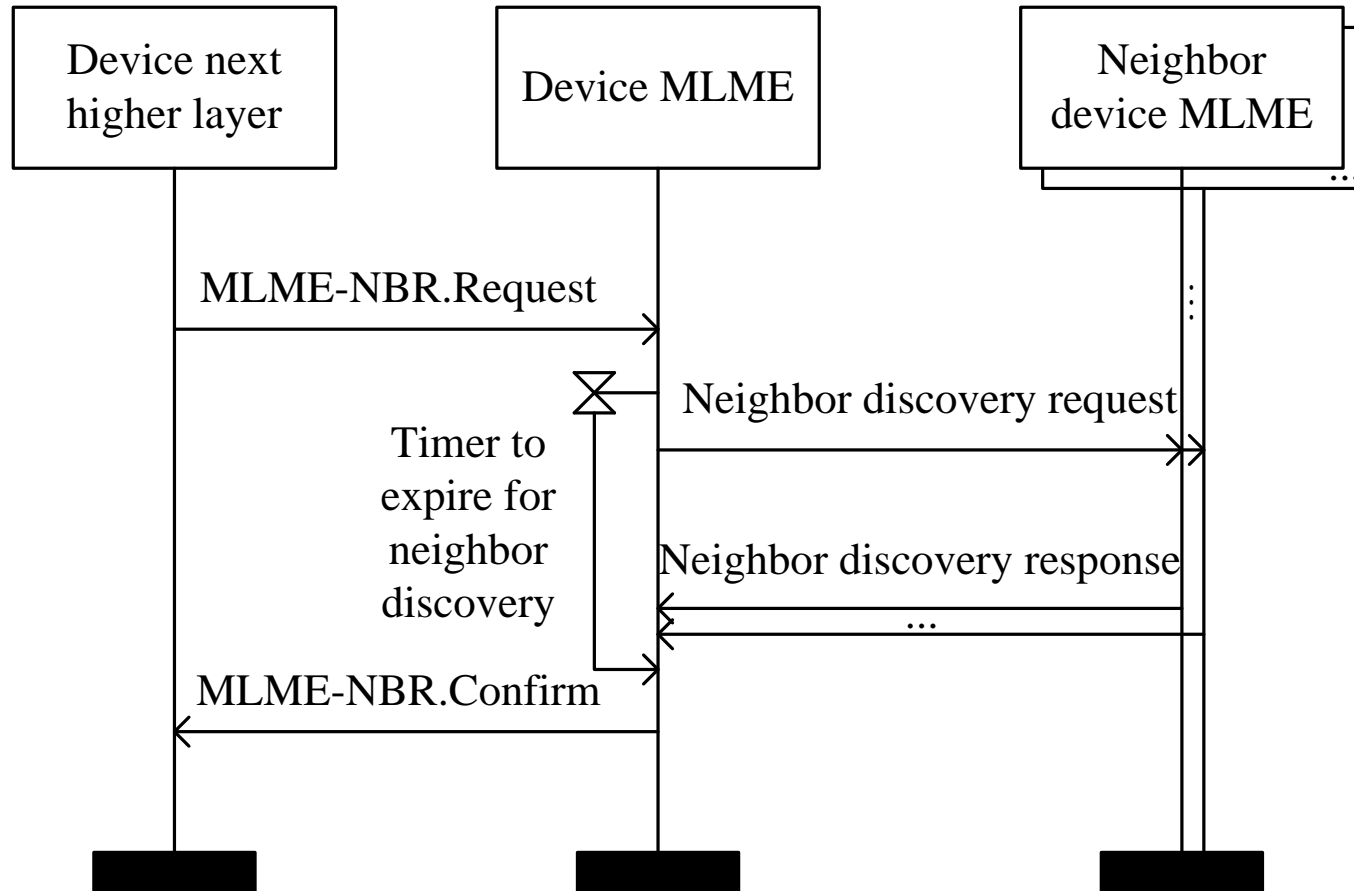

Message Sequence Chart for Neighbor Discovery (cont.)

- // requestor action – sending request //
 - Upon receiving MLME-NBR.Request primitive from next higher layer, at appropriate time a device broadcasts Neighbor Discovery Request command and starts a timer that will expire after [TBD].
- // neighbor device action – responding to request //
 - If a recipient device of the Neighbor Discovery Request command associated with the same coordinator as the requester, it sends Neighbor Discovery Response command to the requester device.

Message Sequence Chart for Neighbor Discovery (cont.)

- // requester action – adding neighbor //
 - When receives a Neighbor Discovery Response command before expiration of the timer, the requester adds the sender to neighbor list if it is not included. The requester device ignores Neighbor Discovery Response command received after expiration of the timer.

- // requester action – reporting to higher layer //
 - After the timer expires, the requester MAC issues MLME-NBR.Confirm primitive to next higher layer.

Mechanism of Direct Device-to-device Data Transfer

- Four modes of direct data transfer are proposed:
 1. Probing Mode – hi, are you there? I have data for you!
 2. Polling Mode – hi, do you have data for me?
 3. Broadcast Mode – to broadcast data to all neighbor devices
 4. Multicast Mode – to send data to a list of neighbor devices

Additions and Modifications when Compared to Legacy Data Transfer Methods

| | Coordinator to Device | Device to Coordinator | Probing mode | Polling Mode | Broadcast Mode | Multicast Mode |
|-------------------------------|--|--|---|---------------------------------------|--|--|
| Beacon-enabled PAN | Indicating data pending in beacon; sends data to device when request | Device sends to coordinator when synchronize | Source device probes status of destination device before transmitting | Device polls neighbor device for data | Device simply broadcasts data to neighbor devices directly | Device simply multicasts data to a list of neighbor devices directly |
| Non-beacon Enabled PAN | Device polls coordinator for data | Device simply transmits to coordinator | | | | |

Probing Mode

- // if status of neighbor is known, it is unnecessary to probe //
 - In Probe-mode direct data transfer, if a device has data for a neighbor device and it is known that the receiver status of the neighbor device is “on”, the device sends data to the destination device at appropriate time.
- // if neighbor status is unknown, it needs to probe status //
 - If the receiver status of the neighbor device is unknown, it sends Probe command to the destination device and starts timer with duration of [TBD -- *macAckWaitDuration*].
- // in case no ACK received, the neighbor is unreachable //
 - If it receives no acknowledgement of the Probe command from the neighbor destination device before expiration of the timer, the destination device is concluded unreachable at this moment.

Probing Mode (cont.)

- // when receives ACK, the neighbor is “on” //
 - If before expiration of the timer, it receives acknowledgement of the Probe command from the neighbor destination device, it sends the data to the neighbor device at appropriate time.
- // to remind more data pending //
 - Before sending data to the destination neighbor device, if the device has more data to the destination neighbor device, it sets the Frame Pending field of the data packet to ONE, otherwise it sets the Frame Pending field of the data packet to ZERO.
- // probe message needs being acknowledged //
 - On receiving a Probe command, a destination device shall send acknowledgement and enable its receiver for at most [TBD -- *macMaxFrameTotalWaitTime*] to receive data from the source device.

Probing Mode (cont.)

- // neighbor device receives data and may acknowledge //
 - If it receives data before expiration of the timer, it acknowledges receipt of the data if it is required. If the Frame Pending field of the data is ONE, it continues to enable its receiver for at most [TBD -- *macMaxFrameTotalWaitTime*].
- // in case destination device is unreachable, two options//
 - If the destination device is detected unreachable, there are two options for the source device: (a) the data can be sent to its coordinator and then the coordinator sends the data to the destination device; (b) the data frame remains in transaction queue until another request from higher layer or *macTransactionPersistenceTime* is reached.
- // data transaction will be discard in case
 - If *macTransactionPersistenceTime* is reached, the transaction information will be discarded, and the MAC sublayer will issue a failure confirmation to the next higher layer.

Message sequence of Probe-mode direct data transfer

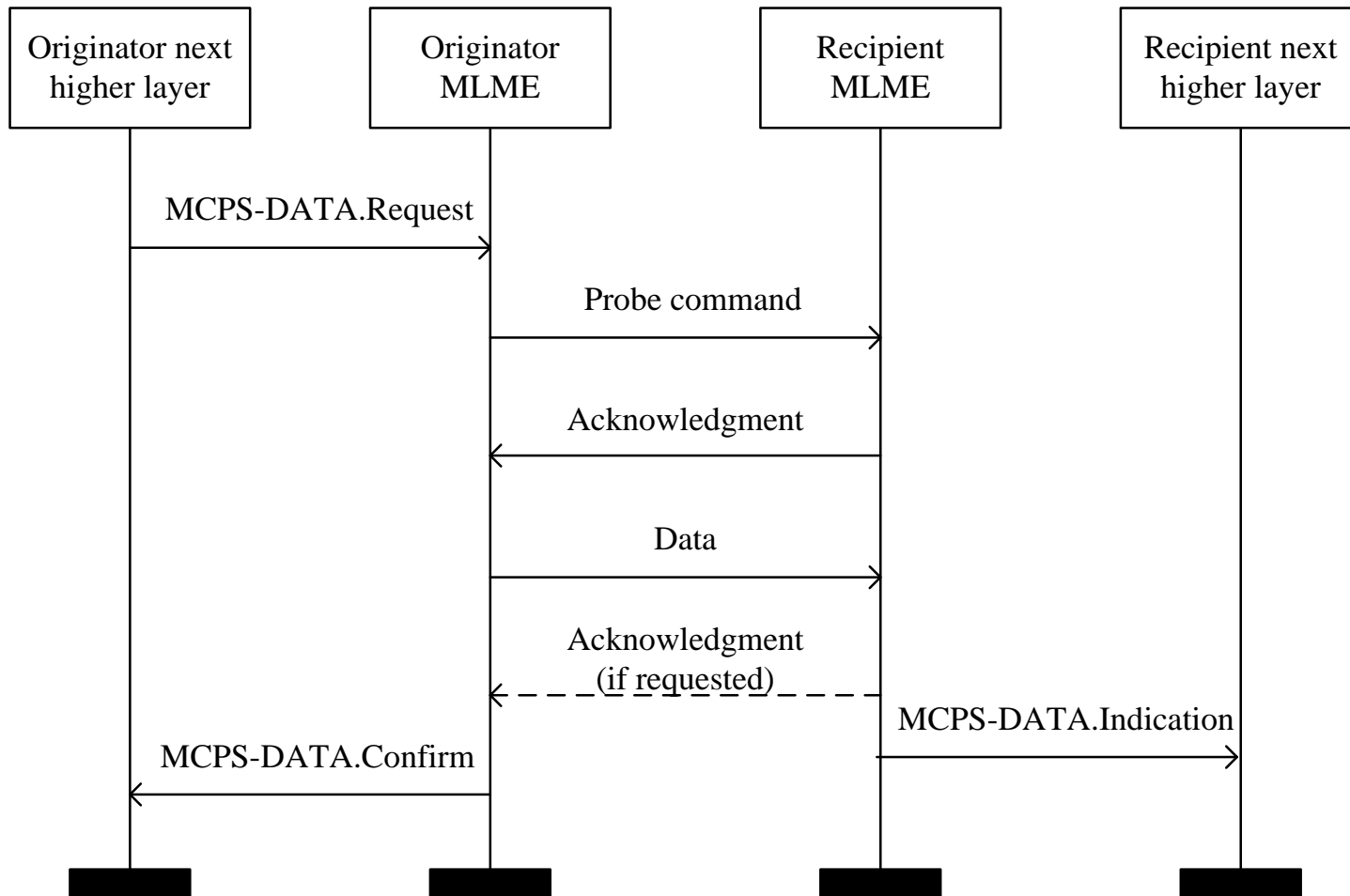

Polling Mode

- // polling-mode data transfer is passive //
 - In Polling-mode direct data transfer, a device keeps data in transaction queue until the data is successfully transmitted to the destination neighbor device or it has to be removed due to resource overflow.
- // polling device sends polling message //
 - With Polling-mode direct data transfer, when a device's MAC sublayer receives MLME-POLL.request primitive from next higher layer, it sends Data Polling command to a target neighbor device at appropriate time and starts a timer with duration of [TBD -- *macAckWaitDuration*].
- //polled device acknowledges polling message //
 - On receiving a Data Polling command, a device shall send acknowledgement to confirm successful reception of the command and indicate whether it has data pending for the polling neighbor.

Polling Mode (cont.)

- // polled device marks data indication //
 - If before sending the acknowledgement of Data Polling command, the polled device is able to determine that it has data pending for the polling device, it sets the Frame Pending field of the acknowledgement to ONE. If it is able to determine that it has no data pending for the polling device, it sets the Frame Pending field of the acknowledgement to ZERO. If it has no enough time to determine whether it has data pending for the polling device, it sets the Frame Pending field to ONE.
- // in case no ACK received at polling device //
 - If before expiration of the timer, the polling device receives no acknowledgement of the Data Polling command, it concludes that the neighbor device is not reachable at this moment. The polling device MAC sublayer shall issue a failure confirmation to next higher layer.

Polling Mode (cont.)

- // in case frame pending is ZERO //
 - If before expiration of the timer, the polling device receives acknowledgement with the Frame Pending field set to zero, it concludes that there is no data pending at the neighbor device.
- // in case frame pending indication is ONE //
 - If before expiration of the timer, the polling device receives acknowledgement with the Frame Pending field set to one, it shall enable its receiver for at most [TBD] to receive the corresponding data from the neighbor device.

Polling Mode (cont.)

- // data receiving at polling device //
 - If the polling device does not receive a data frame from the neighbor device within [TBD] or if the polling device receives a data frame from the neighbor device with a zero length payload, it shall conclude that there are no data pending at the neighbor device. If the polling device does receive a data frame from the neighbor device, it shall send an acknowledgment frame, if requested, thus confirming receipt of the data frame.
- // in case more data pending //
 - If the Frame Pending field of the data frame received is one, then the neighbor device has more data pending. In this case it may extract the data by sending a new Data Polling request command to the neighbor device.

Message Sequence Chart of Polling-Mode Direct Data Transfer

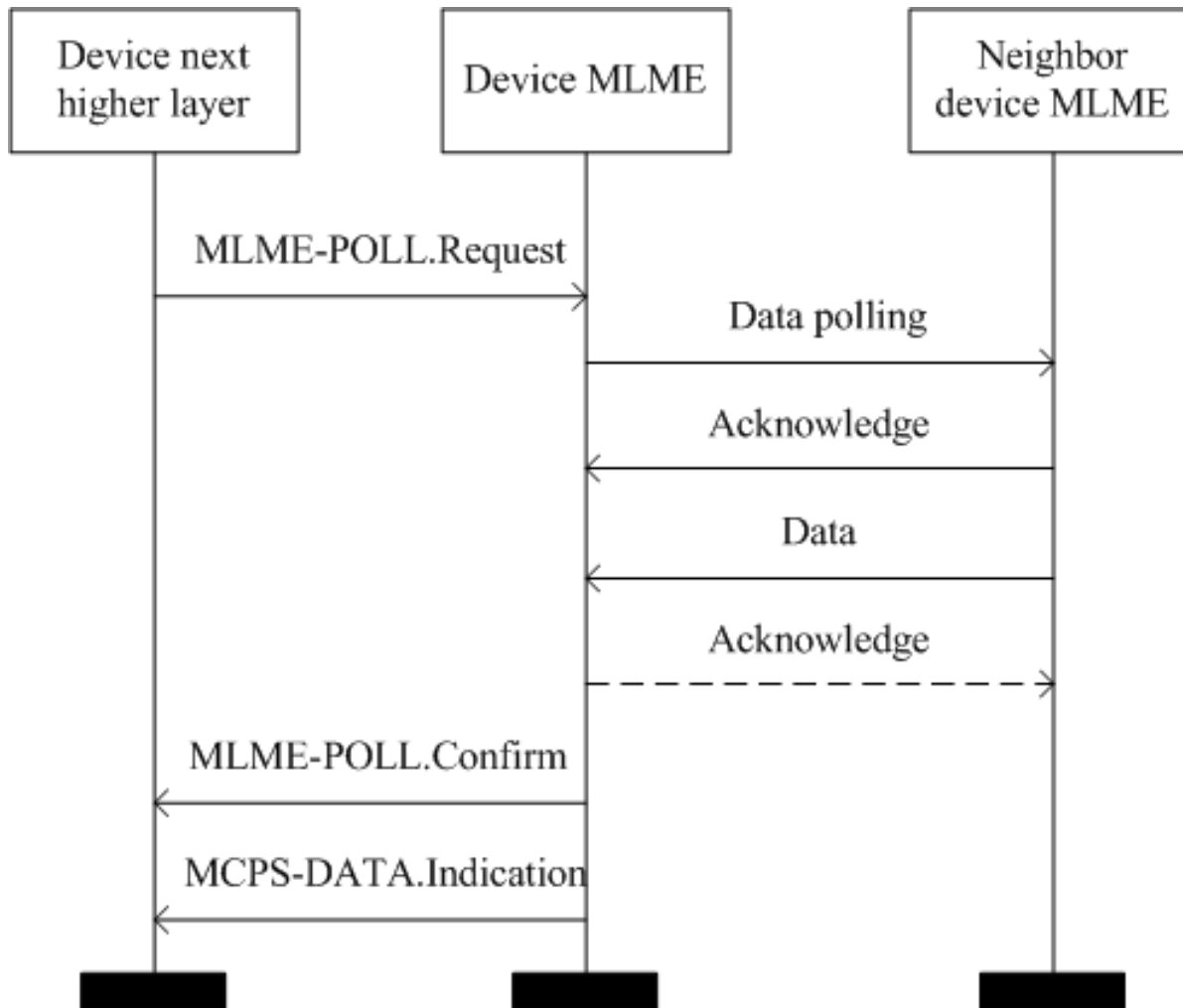

Broadcast Mode

- // data is broadcasted directly when higher layer request //
 - In Broadcast-mode direct data transfer, upon receiving higher layer MCPS-DATA.Request primitive for broadcasting a data frame, a device broadcasts the data frame at appropriate time, [TBD -- by using CSMA/CA algorithm]. The AR field of the data frame shall be set to indicate no acknowledgement requested.

Message Sequence Chart of Broadcast-Mode Direct Data Transfer

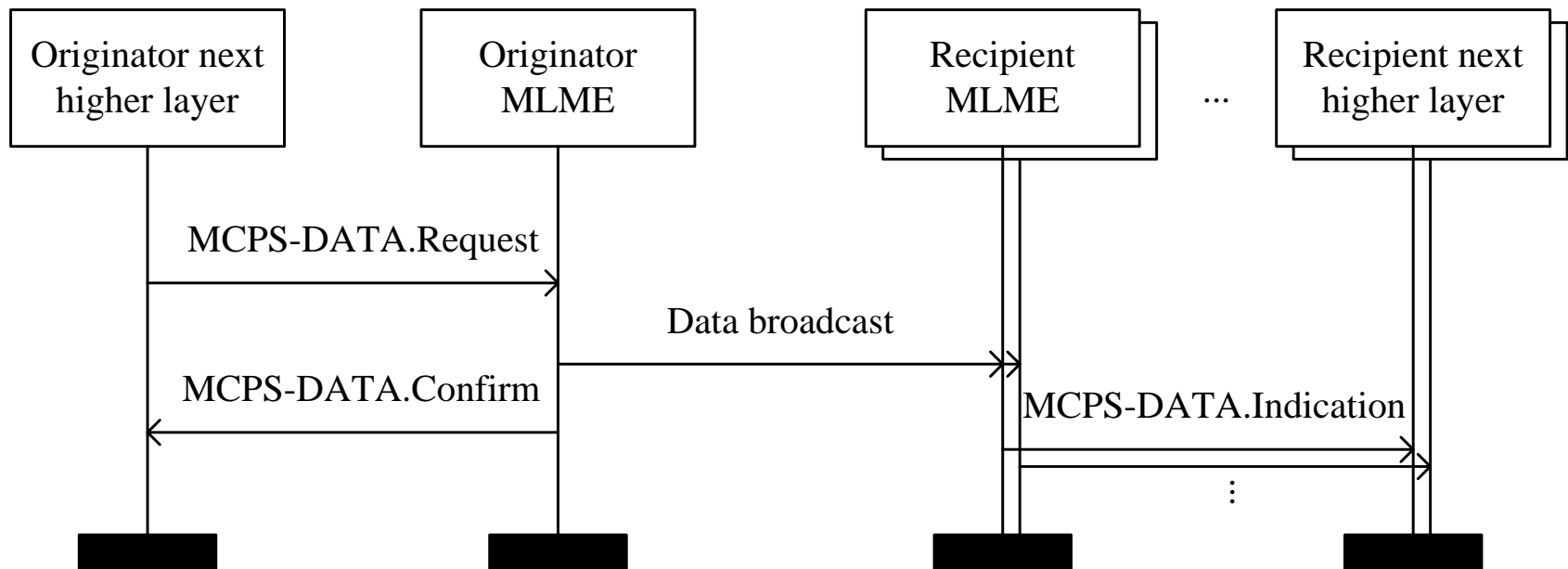

Multicast Mode

- // data is sent out directly when higher layer request //
 - A device multicast a data frame to a subset of its neighbor devices upon receiving higher layer MCPS-DATA.Request primitive with type of Multicast. A multicast data frame may request acknowledgement.
- // data receiver needs to subscribe multicast group //
 - A device may subscribe a multicast group by enabling reception of data frames destined for corresponding multicast address. The format of multicast address is [TBD].

Message Sequence Chart of Multicast-Mode Direct Data Transfer

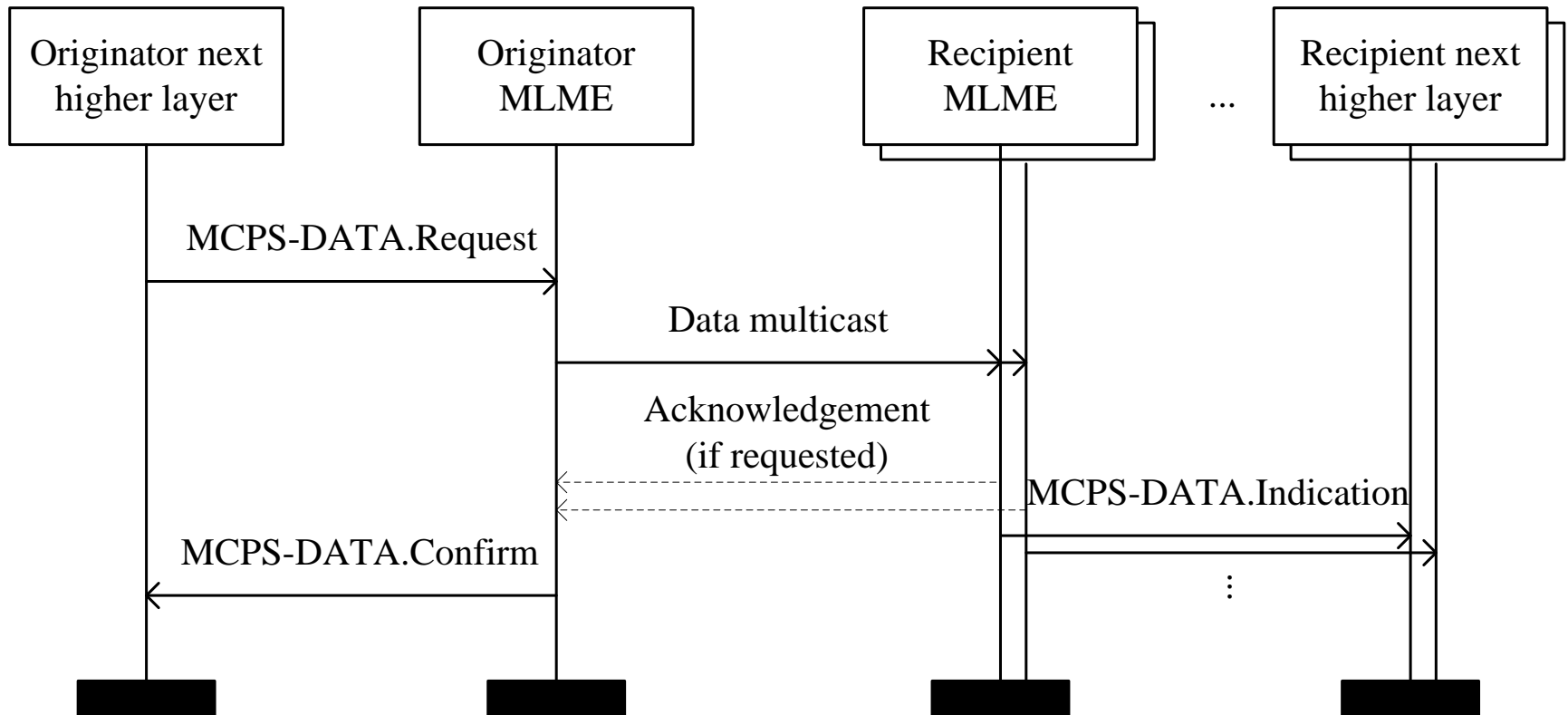

Co-existence among TG4m MAC modifications

- TG4m-MAC should achieve co-existence among not only previous modifications but also further expansions as follow:
 1. TVWS Multi-Channel Utilization (TMCU)
 - Enhancement on GTS allocation and management function
 2. Spectrum Management
 - Definition of Sensing function
 3. Ranging
 - Definition of Ranging function, or enhancement on Beacon IE

APPENDIX

Appendix: BER Performance of proposed FEC

- Recursive systematic coder with Viterbi decoder has comparable performance with non-systematic coder (133,171) in coding rate of 1/2
- The proposed concatenated code outperforms single systematic coder with further coding gain of 1.5 dB at BER=10⁻⁶

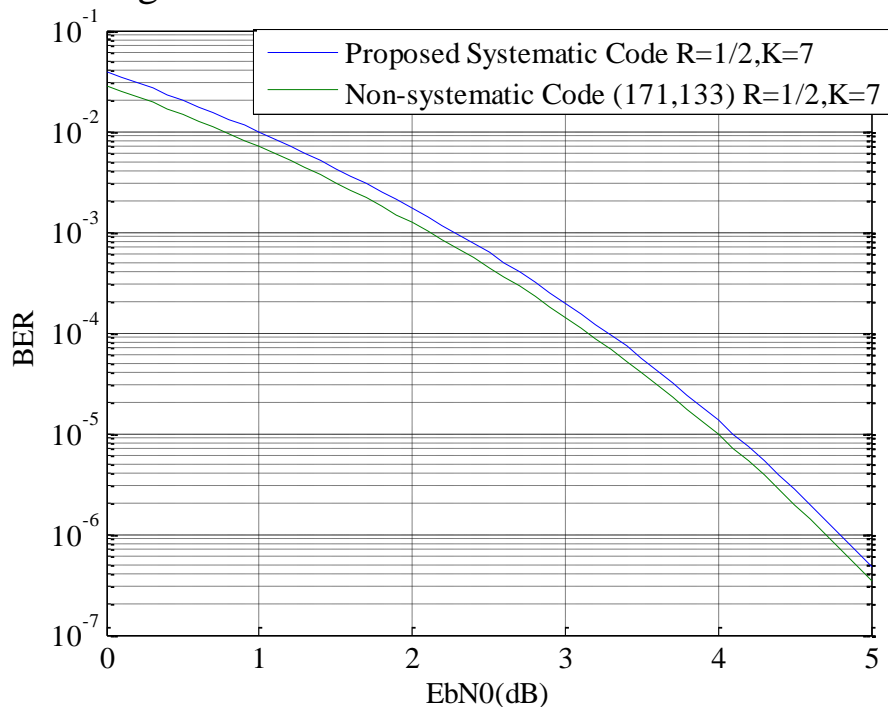

Comparison in theoretical performance of systematic and non-systematic convolutional coder /Viterbi decoder (R=1/2)

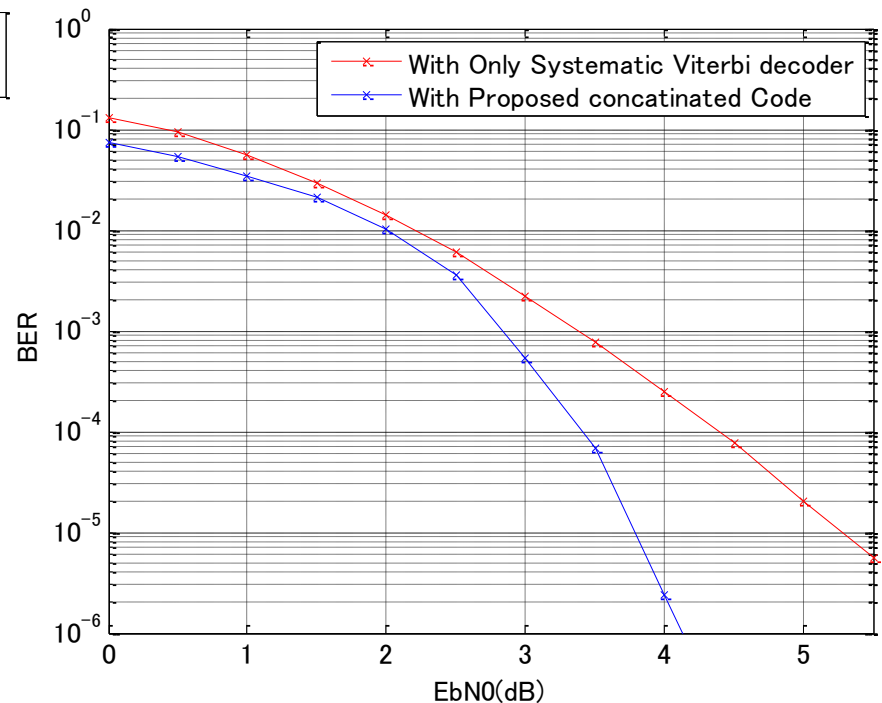

Comparison in systematic convolutional code and concatenated code (traceback length:64, soft bit: 3bit)

Appendix: Validation: PSD of the proposed OFDM PHY Modes #1 and #2

- the revised regulatory limits of portable devices case (i.e., PSD limit (100kHz) of 2.6dBm and adjacent channel limit (100kHz) of -52.8dBm) Satisfied

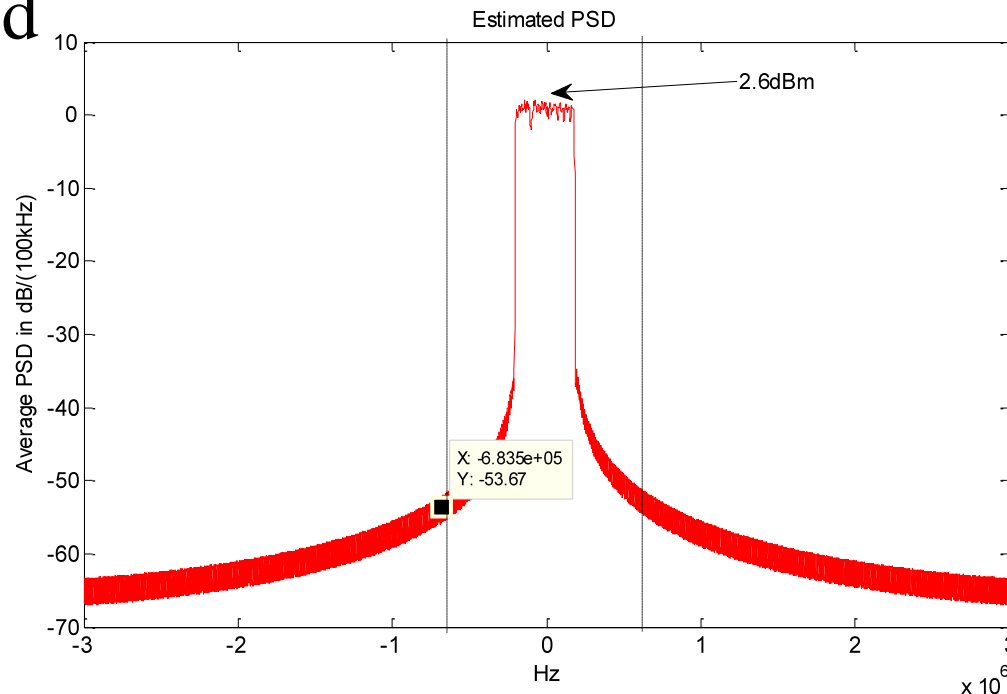

Appendix: Preamble of OFDM Modes #1 and #2

-Auto-correlation of STFs-

- STF

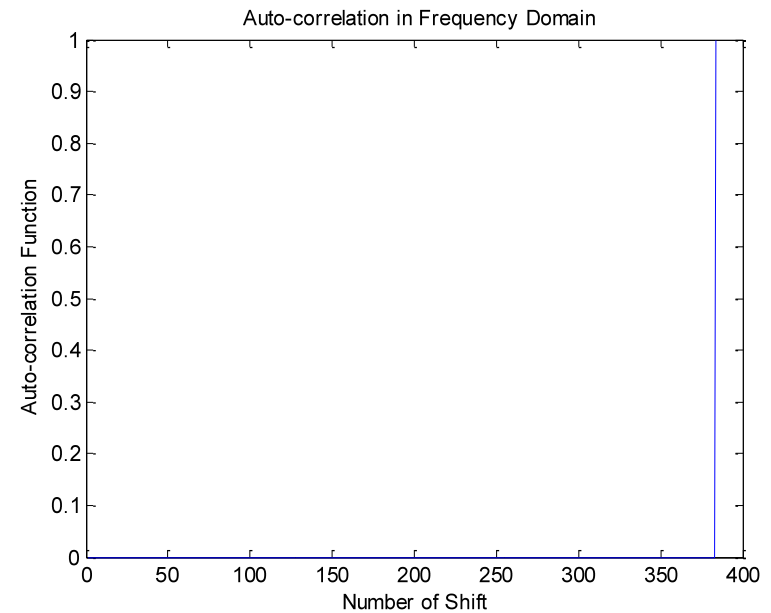
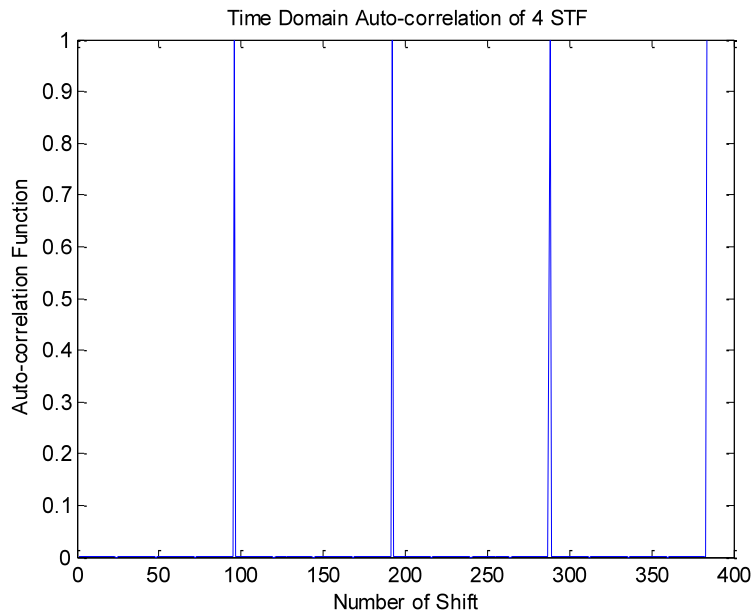

Ideal auto-correlation properties are observed in both time and frequency domains

Appendix: Preamble of OFDM Modes #1 and #2

-Auto-correlation of LTFs-

- LTF

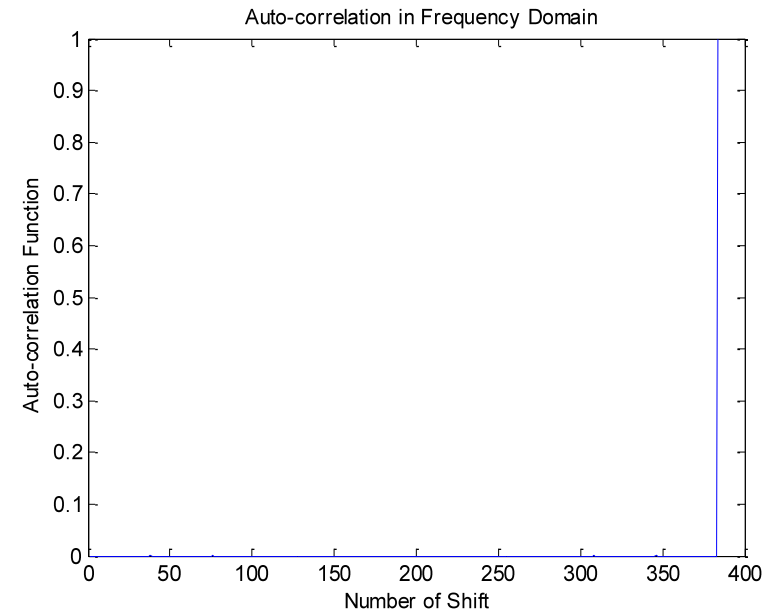
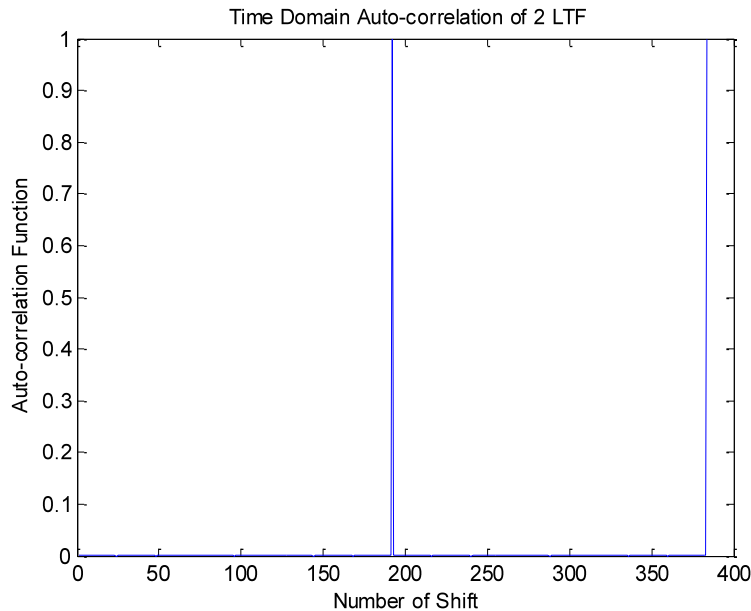

Ideal auto-correlation properties are observed in both time and frequency domains

Appendix: Validation of Estimated PSD of Proposed OFDM System with 11 Channels for 6MHz Bandwidth

For 6MHz bandwidth, there are totally 11 channels, channel spacing = 400kHz, Guard band for adjacent channel is 800kHz for each side.

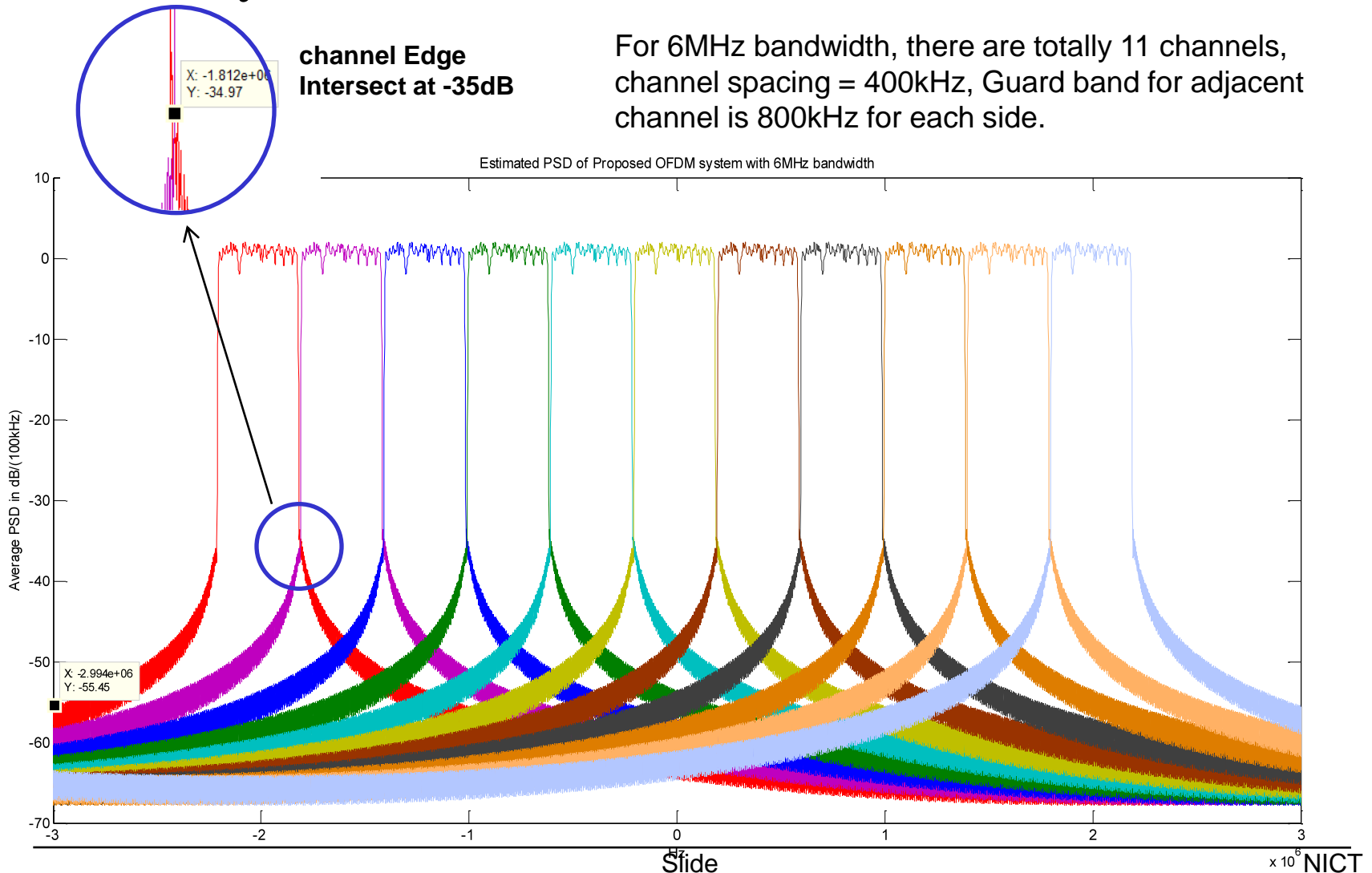

Appendix: Validation of Estimated PSD of Proposed OFDM System with 16 Channels for 8MHz Bandwidth

**Channel Edge
Intersect at -37dB**

For 8MHz bandwidth, there are totally 16 channels, channel spacing = 400kHz, Guard band for adjacent channel is 800kHz for each side.

