

**Project: IEEE P802.15 Working Group for Wireless Personal Area Networks (WPANs)**

**Submission Title:** [LECIM Proposal with data rate adaptation for resilient relay]

**Date Submitted:** [21 Sept. 2011]

**Source:** Name [Shusaku Shimada\*<sup>1</sup>, Kei Sakaguchi\*<sup>2</sup>]

Affiliation [Yokogawa Co.\*<sup>1</sup>, Tokyo Institute of Technology\*<sup>2</sup>]

Address [2-9-32 Nakacho Musashinoshi Tokyo, 180-8750 Japan] \*<sup>1</sup>

[2-12-1 Oookayama, Meguro-ku, Tokyo 152-8550 Japan] \*<sup>2</sup>

Voice: [+81-422-52-5558] \*<sup>1</sup>, FAX: [+81-422-55-3536] \*<sup>1</sup>

E-Mail: [shusaku@ieee.org\*<sup>1</sup>, sakaguchi@mobile.ee.titech.ac.jp\*<sup>2</sup>]

**Re:** [IEEE802.15 TG4k Call for Proposals]

**Abstract:** [Extension of existing two kind of PHY, which are MR-OFDM and DS-DBPSK, are proposed.]

**Purpose:** [To respond CFP of 15.4 TG-k PHY amendment for Low Energy Critical Infrastructure Monitoring applications.]

**Notice:** This document has been prepared to assist the IEEE P802.15. It is offered as a basis for discussion and is not binding on the contributing individual(s) or organization(s). The material in this document is subject to change in form and content after further study. The contributor(s) reserve(s) the right to add, amend or withdraw material contained herein.

**Release:** The contributor acknowledges and accepts that this contribution becomes the property of IEEE and may be made publicly available by P802.15.

## This proposal consists of two parts

Each of which is the minimum extension of existing IEEE802.15.4 PHY to fulfill LECIM requirements with viable CapEx. & OpEx. by enhanced reliability, including data rate adaptation for possible resilient relaying.

Part 1: LECIM extension of MR-OFDM (IEEE802.15.4g), which appends “PUSC” (Partial Usage of Sub-Carriers) technique on existing MR-OFDM scheme to increase per-bit energy of transmission, and to introduce additional diversity gain in time domain. Optionally, this extension is able to accommodate “PUSC-(PHY)-fragmentation” mechanism which improves frequency diversity gain as well, in case of combining with MAC frequency agility, e.g. TSCH of IEEE802.15.4e.

Part 2: LECIM extension of DSSS-BPSK/OQPSK (IEEE802.15.4i), which defines DSSS scheme with FEC using medium chip rates between 100kcps and 1Mcps and higher spreading factor for 120dB path loss of LECIM requirement. It also appends the new channel option in order to reflect the revised regulatory availability of 920MHz band in Japan.

## 15.4k LECIM Overview

- The role of IEEE 802.15 Low Energy Critical Infrastructure (LECIM) Task Group 4k is to create a PHY amendment to 802.15.4 to facilitate **point to multi-thousands of points communications for critical infrastructure monitoring devices.**
- The amendment addresses the application's user needs of **minimal network infrastructure**, and enables the collection of **scheduled and event data from a large number of non-mains powered end points** that are widely dispersed, or are in challenging propagation environments.
- To facilitate **low energy operation necessary for multi-year battery life**, the amendment minimizes network maintenance traffic and device wake durations.
- **In addition**, the amendment addresses **the changing propagation and interference environments.**

## 15.4k PAR

- **Scope:** This standard is an amendment to IEEE 802.15.4. It addresses principally those applications such as critical infrastructure monitoring. It defines an alternate PHY and only those MAC modifications needed to support its implementation.

The amendment supports:

- **Operation in any of the regionally available licensed, license exempt, and special purpose frequency bands**
  - **Simultaneous operation for at least 8 co-located orthogonal networks**
  - **Application data rate of less than 40 kbits per second**
  - **Propagation path loss of at least 120 dB**
  - **>1000 endpoints per mains powered infrastructure**
  - **Asymmetric application data flow**
  - **Extreme difference in capabilities and performance between endpoint devices and coordinating devices (collectors)**
    - coordinator may support all standardized modulations (MCS) and data rates
    - coordinator may be required to support antenna diversity or antenna beam steering
    - end point must be able to conserve energy
  - **Reliable operation in dramatically changing environments (no control over environment)**
- This amendment also provides mechanisms that enable coexistence with other systems in the same band(s) including IEEE 802.11, 802.15 and 802.16 systems. (See explanatory notes in Section 8.1)
  - **Need for the Project:** To address the monitoring and management needs of Critical Infrastructure applications such as water, transportation, security, bridges; to enable preventative maintenance, safety, reliability and cost reduction through operational efficiency.

The response to request for application presentations by the Low Energy Critical Infrastructure Monitoring (LECIM) Interest Group indicate a large and growing market for wireless critical infrastructure applications that fit the objectives of IEEE 802.15, but are not satisfied by existing IEEE 802 standards. (See explanatory notes in Section 8.1).

The LECIM Interest Group tutorial held in San Diego, CA, and previous interest group meetings in Beijing and Orlando have had average attendance of more than 50 participants. There has been substantial interest from regions of the world outside of North America, where the regulatory limits on transmitted power are much lower, in addition to broad interest to better address non-mains powered networks, and hard to reach devices. There have been 6 application presentations, from 10 author companies, with 15 applications described. They are summarized in document 15-10-0533-00-leci-lecim-tutorial-application-presentations.pptx. (See explanatory notes in Section 8.1).

## Viable CapEx & OpEx with Reliable LECIM (Initial Proposal)

- **Reliable Link with appropriate coverage justifying CapEx**
  - **Proposed appropriate frequency bands : 900MHz and 2.4GHz**  
( due to better propagation & interference )
  - **MCS based on Channel Characteristics : 5dB ~ 7dB Eb/No with FEC**  
( @~BER  $10^{-3}$  )
  - **Diversity : Frequency, Time, Space (Antenna) as well as Path.**  
( regardless of short packet (block) length )
- Battery Power Life with necessary data transmission frequency
  - **Battery Life affects directly in OpEx : ~ 10 years @ 10 packets / 1 hour**
- Channel Diversity and Path Resiliency ( spatial, temporal and frequency )
  - **Contingency Cost on OpEx : Resiliency against Single point of failure.**

## Resilient Relay with Rate Adaptation (Initial Proposal)

- **PHY**

- Utilizing Sub 1GHz bands as well as 2.4GHz.
- Considering existing 15.4 PHY with 15.4e MAC, especially Slow Channel Hopping.
- Enhancing reliability using FEC and Reinforced diversity.

- **Resiliency**

- Data Rate Adaptation for detouring relay in order to preserve Battery Life
- One (route) hop neighbor management and Rate Adaptation info.
- Slower (less than 40kbps) data rate with resiliency doesn't mean too slow latency.

## Link resource allocation and management based on Slower Channel Agility

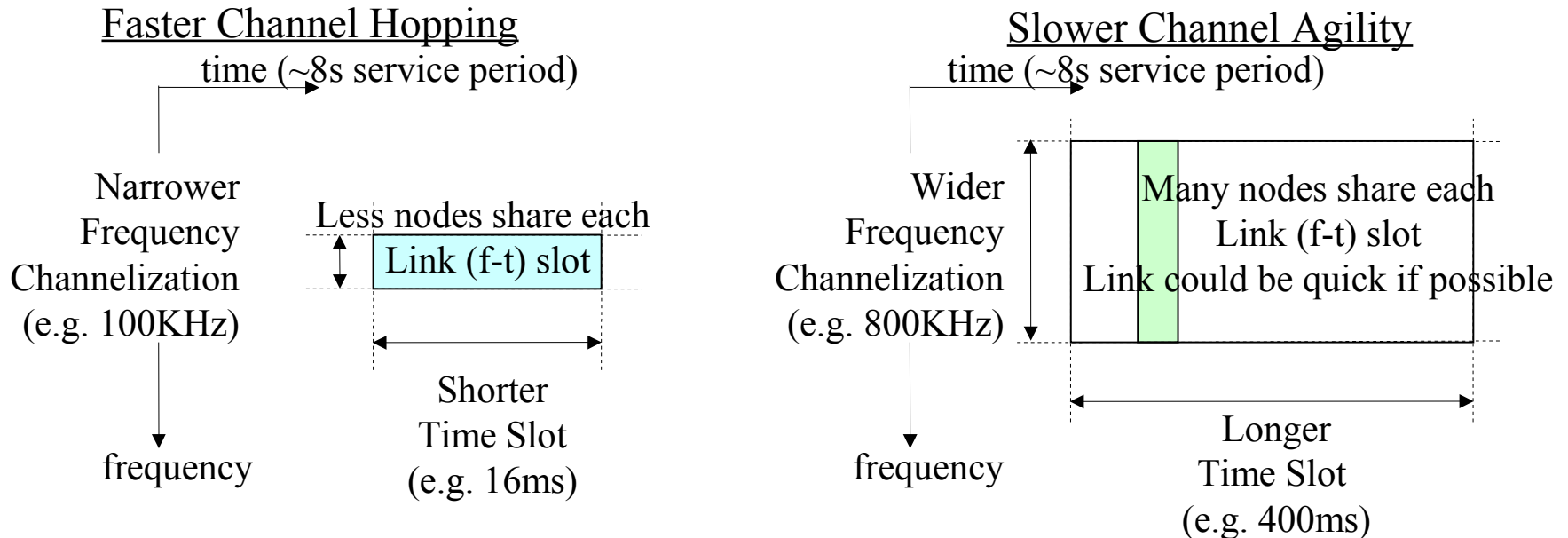

- **8 co-existing network with more than 1000 nodes each > 10000 nodes**
  - 10000 nodes have to share the frequency and time (or code) resource.
- **CSMA type sharing of link (f-t) slot may facilitate the management.**
  - **Variable Data rate adaptation using SF** and relaying still maintain network resiliency.

( OFDM-PUSC and DSSS-PSK )

## IEEE802.15.4x Existing PHY Overview (except for UWB)

Std 15.	Modulation Scheme	Data Rates	Channel Spacing	FEC / Interleaver	Rx Sensitivity 10%/250octet (w/t FEC)	Remarks
4i	DS-OQPSK	100kbps	600kHz	No	-85dBm(1%/20octet) w/o FEC	400kcps(25ksymbol/s)
4i	DS-OQPSK	250kbps	2MHz	No	-85dBm(1%/20octet) w/o FEC	1Mcps(62.5ksymbol/s)
4i	DS-OQPSK	250kbps	5MHz	No	-85dBm(1%/20octet) w/o FEC	2Mcps(62.5ksymbol/s)
4i	DS-BPSK	20k/40kbs	600kHz/2MHz	No	-92dBm(1%/20octet) w/o FEC	300kcps/600kcps
4g	DS-OQPSK	31.25k/62.5/125/250/500kbps	2MHz/5MHz	PHR:60bit/PDU:126bit	-110/-105/-100/-95/-90dBm	1Mcps/2Mcps
4g	DS-OQPSK	6.25/12.5/25k/50kbps	200kHz	PHR:60bit/PDU:126bit	-110/-105/-100/-95/-90dBm	100kcps
4f	MSK	31.25k/250kbps	60kHz/580kHz	No		
4i	GFSK	100kbps	400kHz	No	-85dBm(1%/20octet) w/o FEC	for 4d Japan sub-1G
4g	(Filter) FSK	4.8/9.6kbps	12.5kHz	Option/16symbols	-97dBm+10log(R/50kbps)	for US450-470MHz
4g	(Filter) FSK	10/20/40kbps	12.5kHz	Option/16symbols	-97dBm+10log(R/50kbps)	for US928-960MHz
4g	(Filter) FSK	100kbps/150kbps/200kbps	400kHz	Option/16symbols	-97dBm+10log(R/50kbps)	
4g	(Filter) FSK	400kbps	600kHz	Option/16symbols	-97dBm+10log(R/50kbps)	
4g	OFDM	50/100/150/200/300kbps	200kHz	1symbol/xSF(upto192bit)	-105/-103/-100/-97/-94dBm	16DFT(14tones)
4g	OFDM	50/100/200/300/400/600kbps	400kHz	1symbol/xSF	-105/-103/-100/-97/-94/-91dBm	32DFT(26tones)
4g	OFDM	50/100/200/400/600/800kbps	800kHz	1symbol/xSF	-105/-103/-100/-97/-94/-91dBm	64DFT(52tones)
4g	OFDM	100/200/400/800kbps	1.2MHz	1symbol/xSF	-103/-100/-97/-94dBm	128DFT(104tones)



# LECIM-MR-OFDM

## General Structure of LECIM-MR-OFDM PHY scheme

- Sub-carrier spacing ( $10416 \cdot 2/3$  Hz), symbol rate ( $8 \cdot 1/3$  k symbol/s) and 120us ( $96+24$ us) of symbol duration are not changed.
- PUSC schemes are applied on a couple of the lowest data rate MCSs of option 1 (DFT-128) and option 2 (DFT-64) and resulting data rates are halved, quartered and 1/8'ed, down to 25k, 12.5k and 6.25kb/s.
- Subsequently, the power per sub-carrier are increased two, four or eight times than base rate before applying PUSC scheme.
- The application of PUSC schemes are based on either ways of (1) Equi-spaced sub-carriers, or, (2) Random-spaced sub carriers.
- PSDU part of Equi-spaced PUSC is able to be fragmented in 2, 4 or 8 series of PHY sub-frames in fixed fashion according to MCS#, each of which frame length have to be up to 127 octet.
- Random-spaced PUSC shall be used only for non-fragmented manor.

## Additional Data Rates (MCS)

Parameter	OFDM Option 1	OFDM Option 2	OFDM Option 3	OFDM Option 4
Nominal bandwidth (kHz)	1094	552	281	156
Channel spacing (kHz)	1200	800	400	200
DFT size	128	64	32	16
Active tones	104	52	26	14
# Pilot tones	8	4	2	2
# Data tones	96	48	24	12
MCS0 (kb/s) (BPSK rate $\frac{1}{2}$ with 4x frequency repetition)	100	50	—	—
MCS1 (kb/s) (BPSK rate $\frac{1}{2}$ with 2x frequency repetition)	200	100	50	—
MCS2 (kb/s) (QPSK rate $\frac{1}{2}$ and 2x frequency repetition)	400	200	100	50
MCS3 (kb/s) (QPSK rate $\frac{1}{2}$ )	800	400	200	100
MCS4 (kb/s) (QPSK rate $\frac{3}{4}$ )	—	600	300	150
MCS5 (kb/s) (16-QAM rate $\frac{1}{2}$ )	—	800	400	200
MCS6 (kb/s) (16-QAM rate $\frac{3}{4}$ )	—	—	600	300

MCS8/12 (kb/s) (BPSK $\frac{1}{2}$ rate coded, 4x frequency repetition and 2x PUSC)	<b>50</b>	<b>25</b>
MCS9/13 (kb/s) (BPSK $\frac{1}{2}$ rate coded, 4x frequency repetition and 4x PUSC)	<b>25</b>	<b>12.5</b>
MCS10/14 (kb/s) (BPSK $\frac{1}{2}$ rate coded, 4x frequency repetition and 8x PUSC)	<b>12.5</b>	<b>6.25</b>

## Channel page structure for LECIM-MR-OFDM

### MR-OFDM PHY MCS values supported mapping

Bit	Option 1	Option 2	Option 3	Option 4
0	MCS0	MCS0	MCS1	MCS2
1	MCS1	MCS1	MCS2	MCS3
2	MCS2	MCS2	MCS3	MCS4
3	MCS3	MCS3	MCS4	MCS5
4	Reserved	MCS4	MCS5	MCS6
5	Reserved	MCS5	MCS6	Reserved
6	MCS8 / 12	MCS8 / 12	Reserved	Reserved
7	MCS9 / 13	MCS9 / 13	Reserved	Reserved
8	MCS10 / 14	MCS10 / 14	Reserved	Reserved

## **PUSC structure of LECIM-MR-OFDM**

- Following slides show the images of signal spectrum of equi-spaced PUSC scheme.

(Actual spectrum are observed associated side lobes in term of each SC.)

**Original 15.4g MR-OFDM Symbol without PSCU ( before Pilot insertion )**

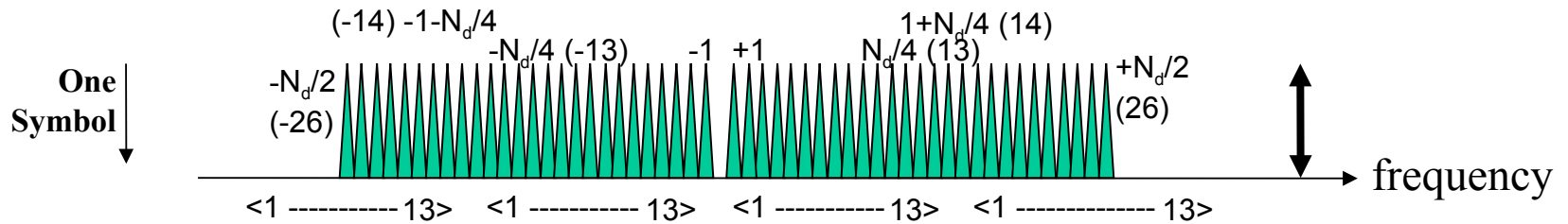

**First half equi-spaced 2 x PSCU symbol (-Even, -Odd, +Even, -Odd Sub-carriers)**

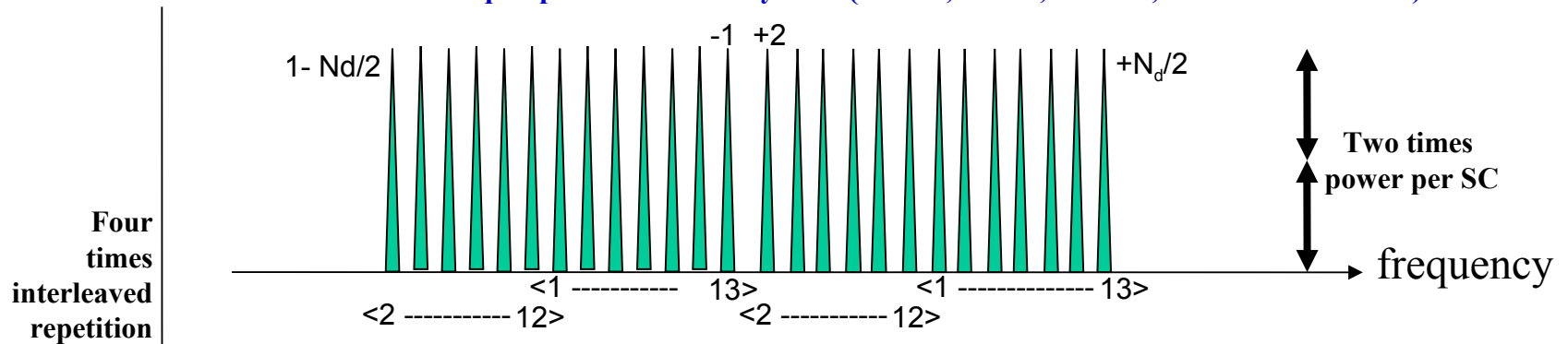

**Second half of equi-spaced 2 x PSCU symbol (-Even, -Odd, +Even, +Odd Sub-carriers)**

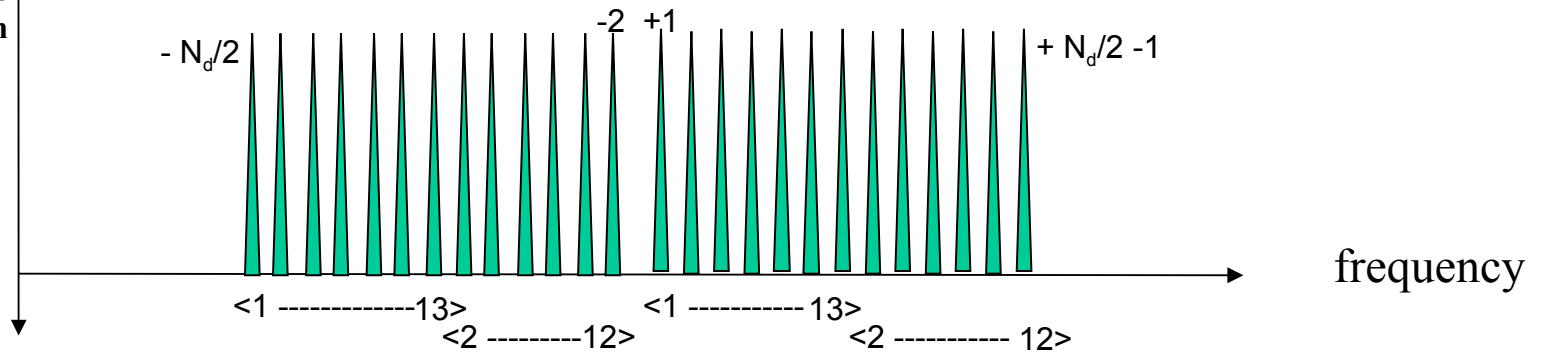

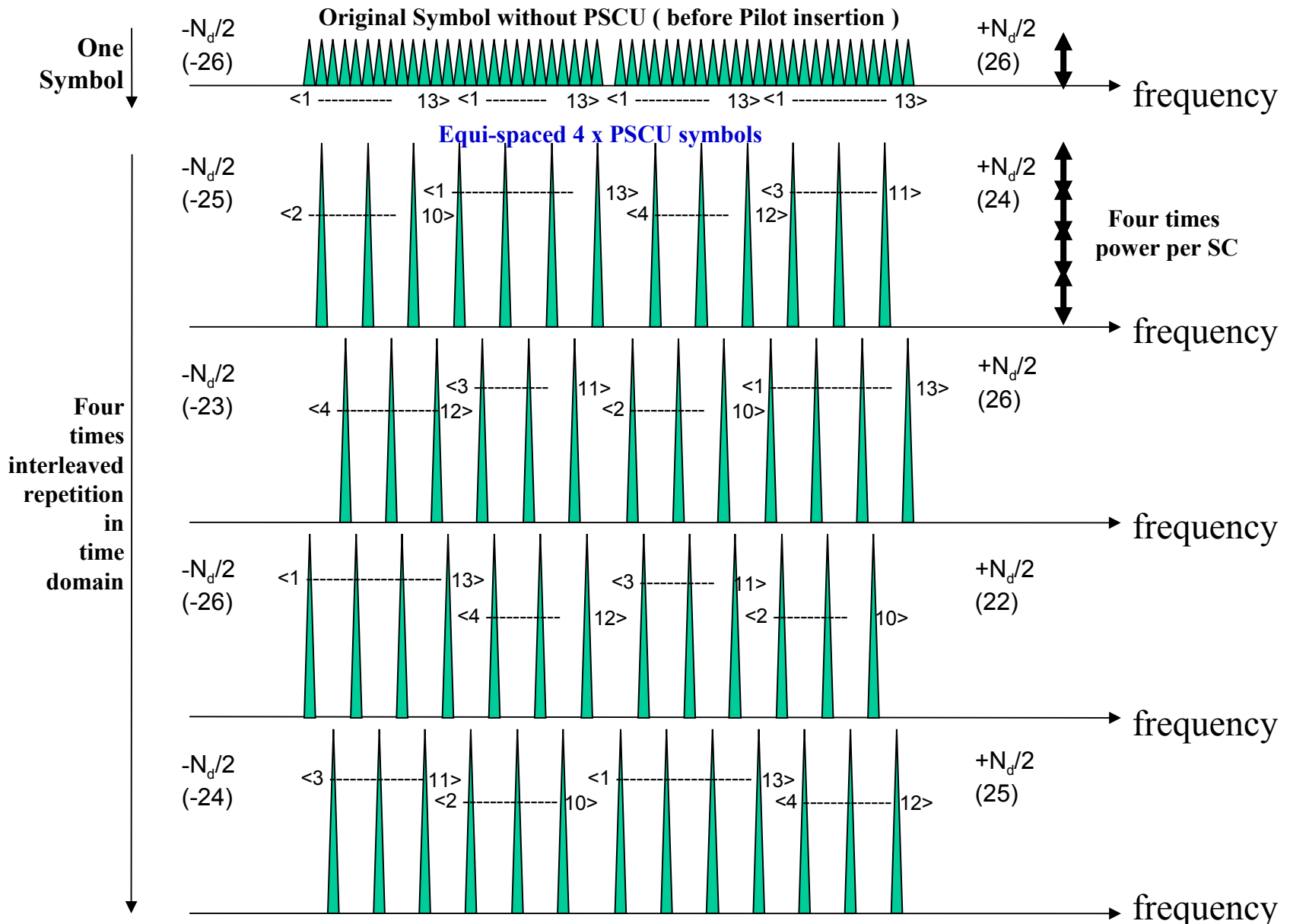

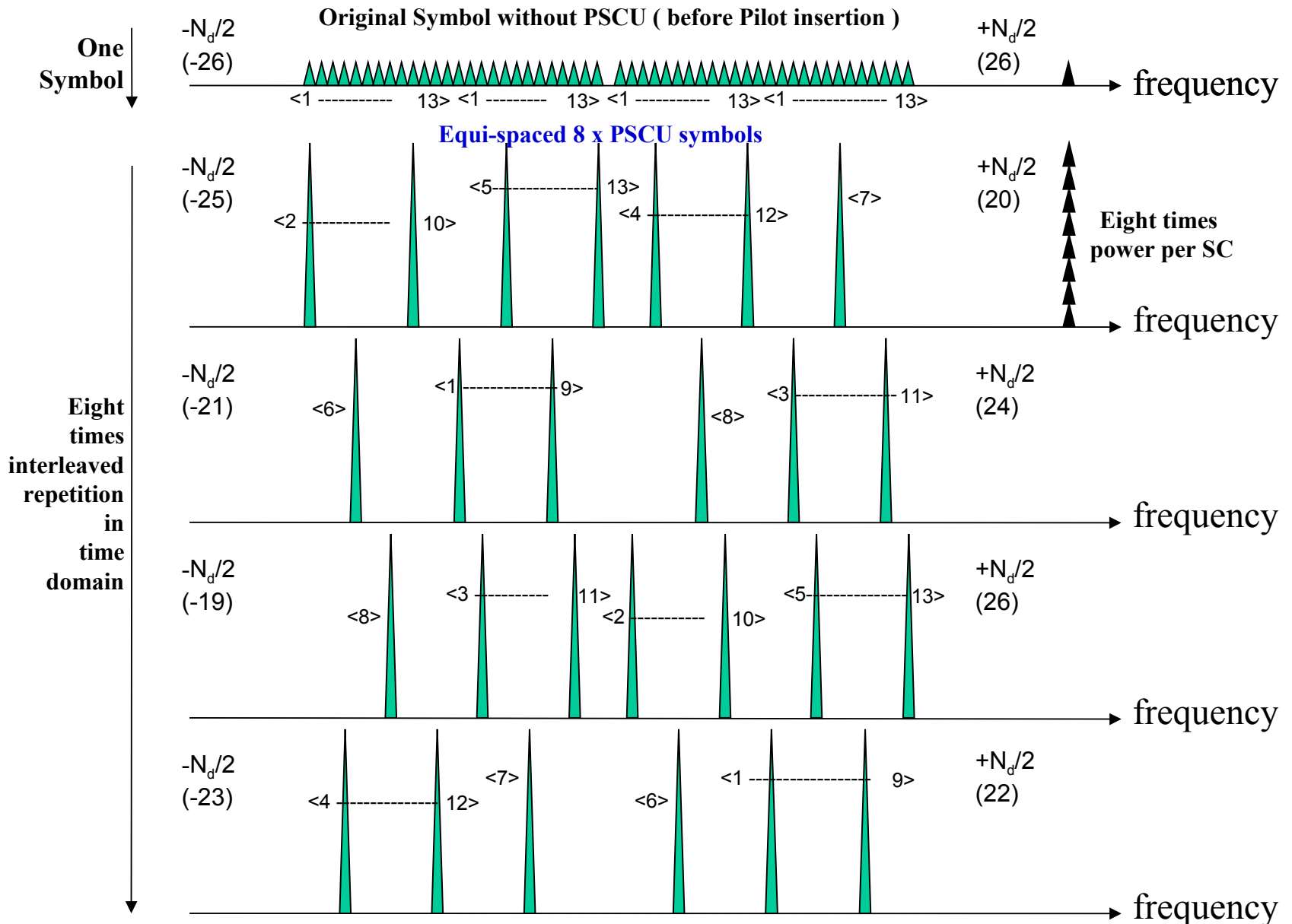



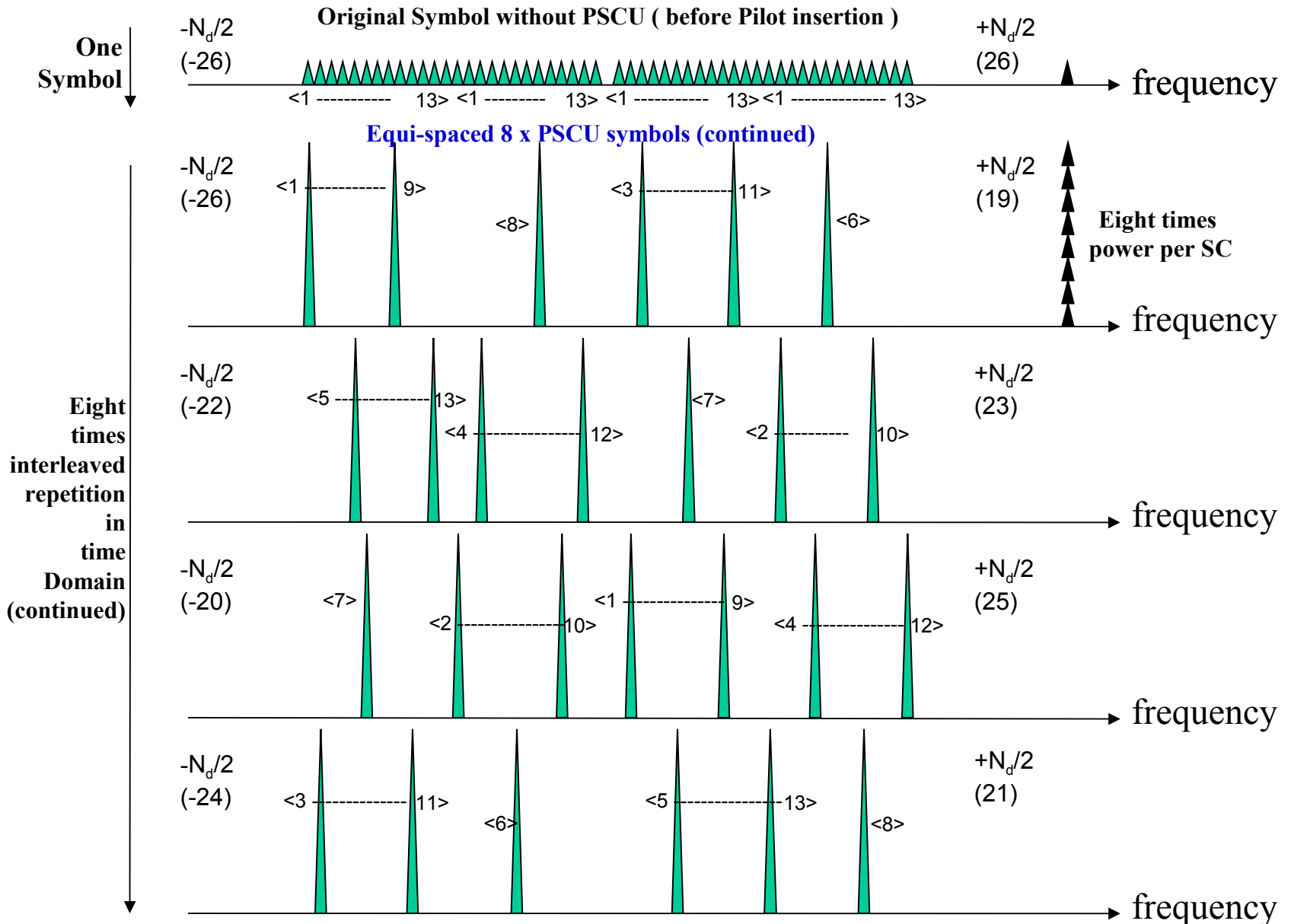

## Example of PUSC selection strategy on each frequency block

1		●			13
2				●	14
3	●				15
4			●		16

-30,-28,-21,-19, -14,-12, -5, -3, 2, 4,11,13, 18,20,27,29
-32,-25,-23,-18, -16, -9, -7, -2, 0, 7, 9,14, 16,23,25,30
-29,-27,-22,-20, -13,-11, -6, -4, 3, 5,10,12, 19,21,26,28
-31,-26,-24,-17, -15,-10, -8, -1, 1, 6, 8,15, 17,22,24,31

1		●						57
2							●	58
3				●				59
4	●							60
5							●	61
6			●					62
7								63
8					●			64

-29,-24,-11,-6,7,12,17,30
-32,-19,-14,-1,4,9,22,27
-27,-22,-9,-4,1,14,19,24
-30,-17,-12,-7,6,11,16,29
-25,-20,-15,-2,3,8,21,26
-28,-23,-10,-5,0,13,18,31
-31,-18,-13,-8,5,10,23,28
-26,-21,-16,-3,2,15,20,25

### PHY header fields for MR-OFDM

Bit string index	0-4	5	6-16	17-18	19-20	21	22-29	30-35
Bit mapping	RA <sub>4</sub> -RA <sub>0</sub>	R	L <sub>10</sub> -L <sub>0</sub>	R <sub>1</sub> -R <sub>0</sub>	S <sub>1</sub> -S <sub>0</sub>	R	H <sub>7</sub> -H <sub>0</sub>	T <sub>5</sub> -T <sub>0</sub>
Field name	Rate	Reserved	Frame Length	Reserved	Scrambler	Reserved	HCS	Tail

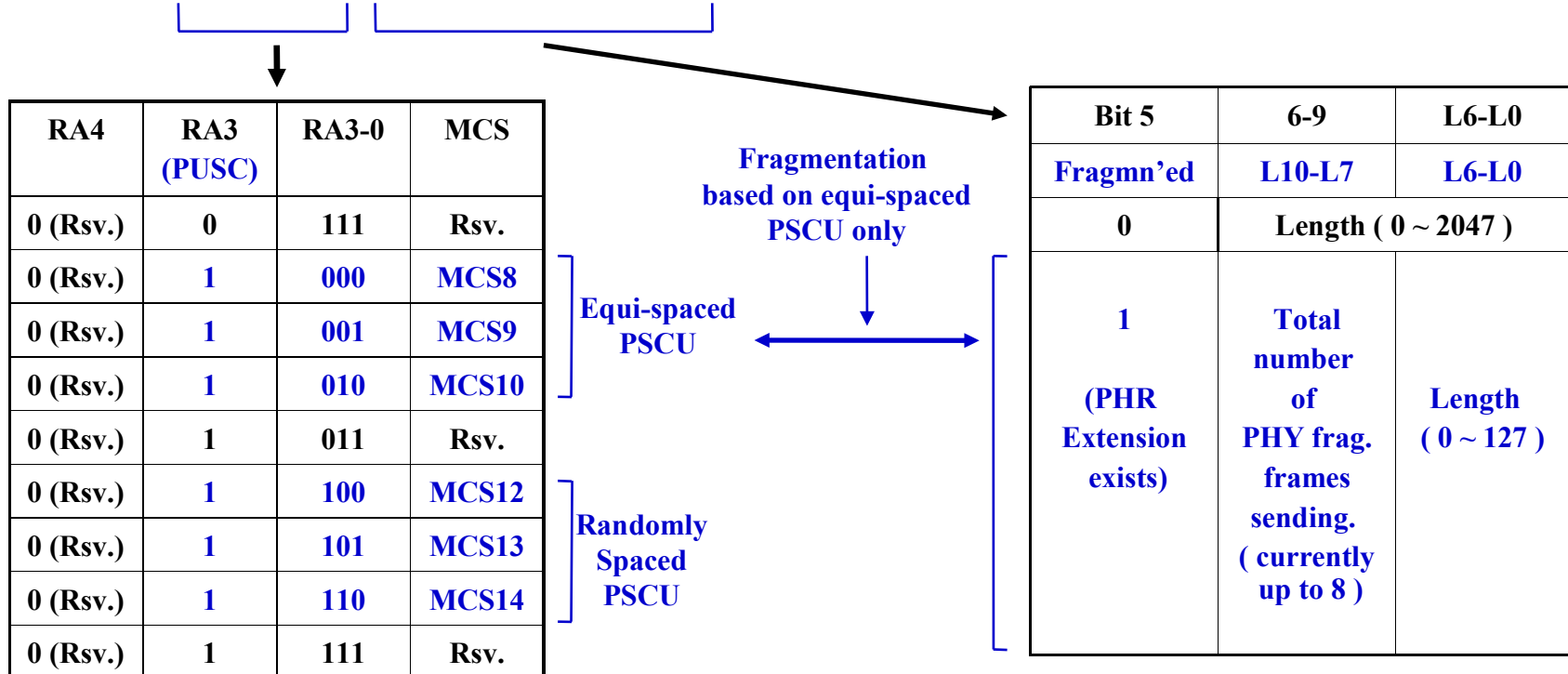

### PHY header fields for MR-OFDM

Bit string index	0-4	5	6-16	17-18	19-20	21	22-29	30-35
Bit mapping	RA <sub>4</sub> -RA <sub>0</sub>	R	L <sub>10</sub> -L <sub>0</sub>	R <sub>1</sub> -R <sub>0</sub>	S <sub>1</sub> -S <sub>0</sub>	R	H <sub>7</sub> -H <sub>0</sub>	T <sub>5</sub> -T <sub>0</sub>
Field name	Rate	Reserved	Frame Length	Reserved	Scrambler	Reserved	HCS	Tail

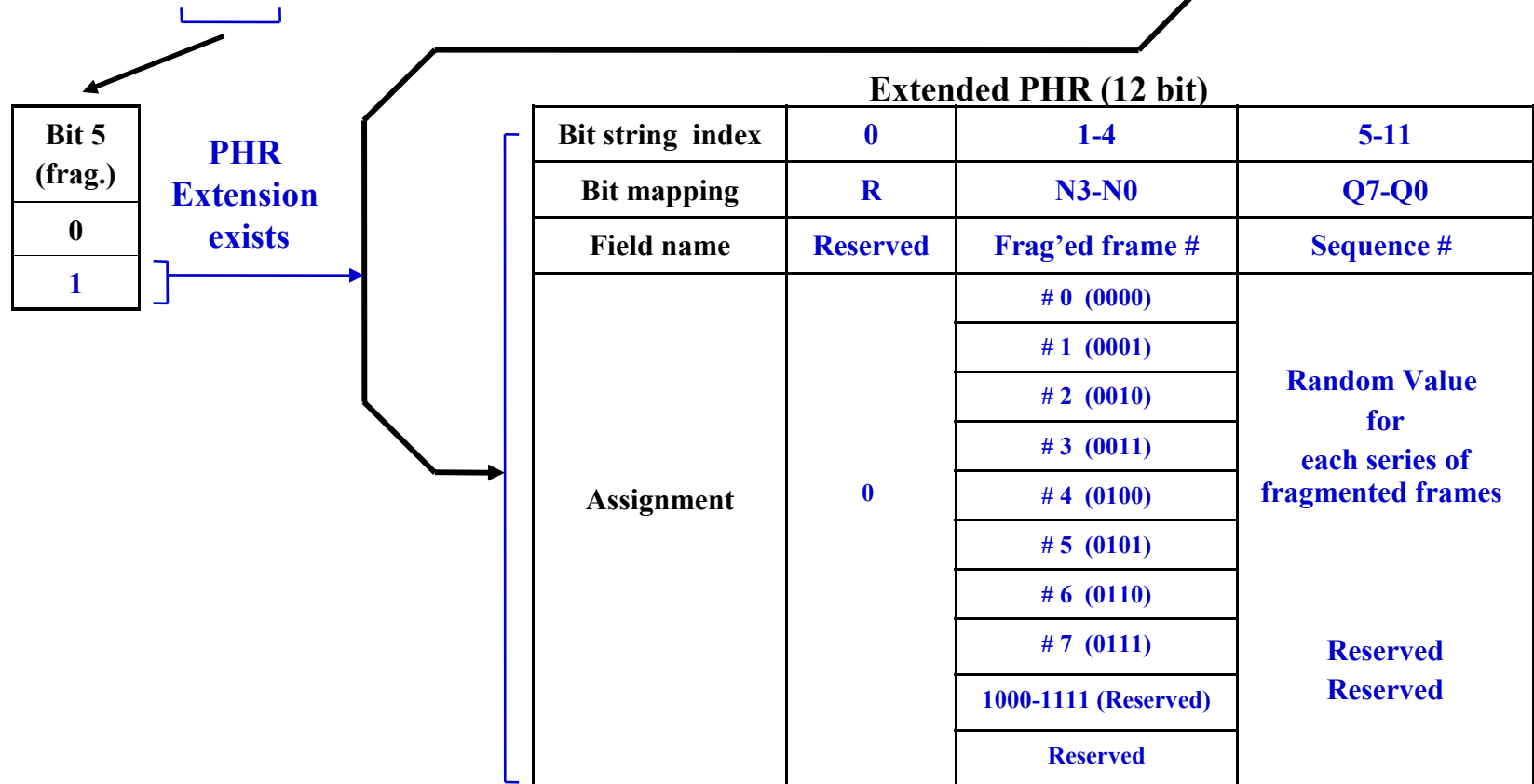

*phySymbolsPerOctet* values for MR-OFDM PHY

MCS level	OFDM Option			
	1	2	3	4
MCS0 (BPSK ½ rate coded and 4x frequency repetition)	2/3	4/3	—	—
MCS1 (BPSK ½ rate coded and 2x frequency repetition)	1/3	2/3	4/3	—
MCS2 (QPSK ½ rate coded and 2x frequency repetition)	1/6	1/3	2/3	4/3
MCS3 (QPSK ½ rate coded)	1/12	1/6	1/3	2/3
MCS4 (QPSK ¾ rate coded)	—	1/9	2/9	4/9
MCS5 (16-QAM ½ rate coded)	—	1/12	1/6	1/3
MCS6 (16-QAM ¾ rate coded)	—	—	1/9	2/9
MCS8/12 (BPSK ½ rate coded, 4x frequency repetition and 2x PUSC)	<b>4/3</b>	<b>8/3</b>		
MCS9/13 (BPSK ½ rate coded, 4x frequency repetition and 4x PUSC)	<b>8/3</b>	<b>16/3</b>		
MCS10/14 (BPSK ½ rate coded, 4x frequency repetition and 8x PUSC)	<b>16/3</b>	<b>32/3</b>		

## Receiver Sensitivity

	Option 1	Option 2	Option 3	Option 4
MCS0 (BPSK $\frac{1}{2}$ rate coded and 4x frequency repetition)	-103 dBm	-105 dBm	—	—
MCS1 (BPSK $\frac{1}{2}$ rate coded and 2x frequency repetition)	-100 dBm	-103 dBm	-105 dBm	—
MCS2 (QPSK $\frac{1}{2}$ rate coded and 2x frequency repetition)	-97 dBm	-100 dBm	-103 dBm	-105 dBm
MCS3 (QPSK $\frac{1}{2}$ rate coded)	-94 dBm	-97 dBm	-100 dBm	-103 dBm
MCS4 (QPSK $\frac{3}{4}$ rate coded)	—	-94 dBm	-97 dBm	-100 dBm
MCS5 (16-QAM $\frac{1}{2}$ rate coded)	—	-91 dBm	-94 dBm	-97 dBm
MCS6 (16-QAM $\frac{3}{4}$ rate coded)	—	—	-91 dBm	-94 dBm

MCS8/12 (BPSK $\frac{1}{2}$ rate coded, 4x frequency repetition and 2x PUSC)	<b>-106dBm</b>	<b>-108dBm</b>
MCS9/13 (BPSK $\frac{1}{2}$ rate coded, 4x frequency repetition and 4x PUSC)	<b>-109dBm</b>	<b>-111dBm</b>
MCS10/14 (BPSK $\frac{1}{2}$ rate coded, 4x frequency repetition and 8x PUSC)	<b>-112dBm</b>	<b>-114dBm</b>

## LECIM-MR-OFDM Frame without Fragmentation

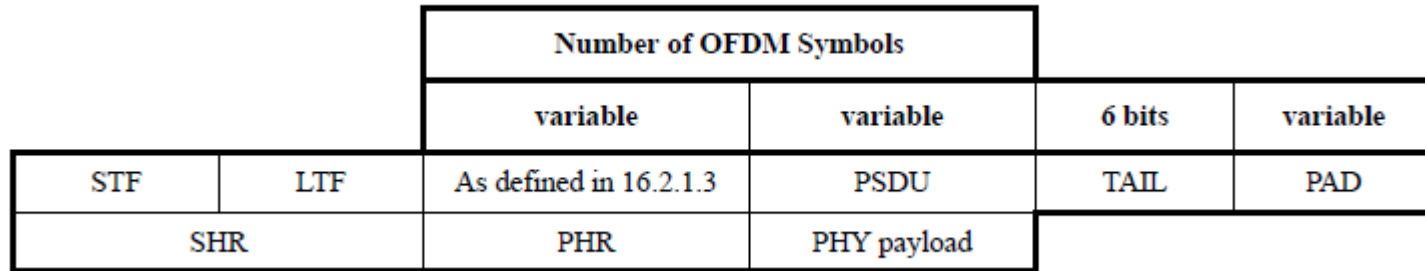

**Increasing per bit energy  
by Reducing data rate**

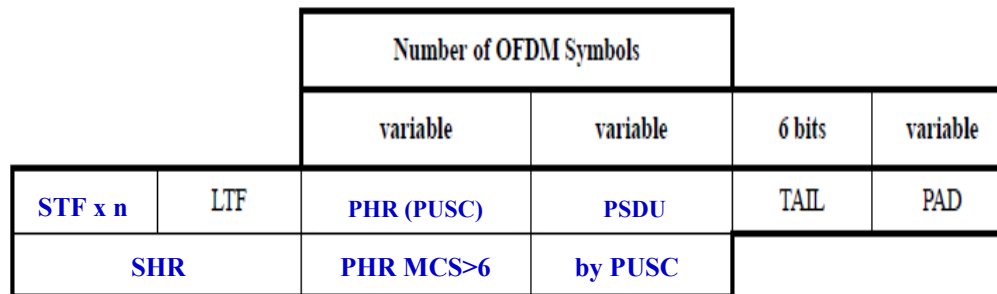

**Note. STF x n : n = 2, 4, 8 repetition**

## Fragmentation of an OFDM Frame

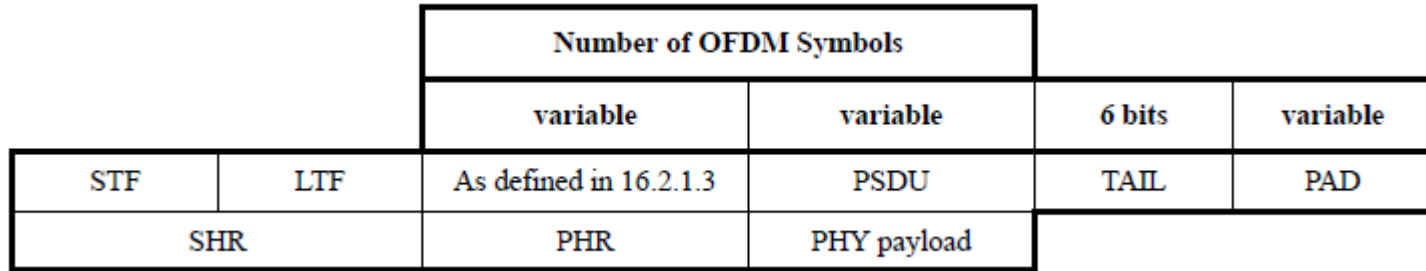

**Increasing per bit energy  
by Reducing data rate**

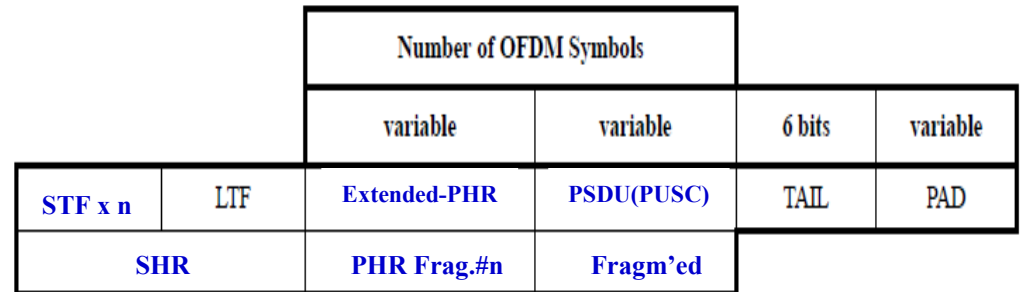
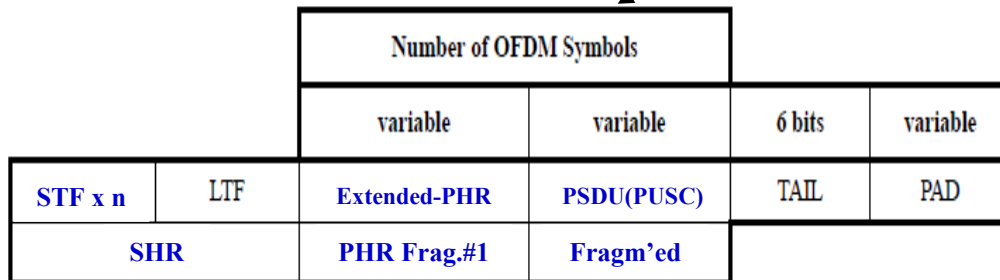

**Note.** STF x n : n = 2, 4, 8 repetition



## Required Voltage excursion at Tx output (v.s. PAPR)

T X Power	V rms at 50ohm (mV)	I rms into 50ohm (mA)	Peak to Peak (Sinusoidal) (mV)	Peak to Peak (AWGN) (mV)	Peak to Peak (AWGN) Differential (mV)
(PAR) →	--	--	2.82	6	3
-10dBm	71	1.42	200.22	426	213
-6dBm	112	2.24	315.84	672	336
0dBm	224	4.48	631.68	1344	672
6dBm	447	8.94	1260.54	2682	1341
10dBm	707	14.14	1993.74	4242	2121
13dBm	1000	20	2820	6000	3000
20dBm	2240	44.8	6316.8	13440	6720

 : 3.3V supply voltage feasible

## AP side Antenna formation

( Counting on 12dBi antenna gain in link calculation )

### High Gain Omni-directional Antenna

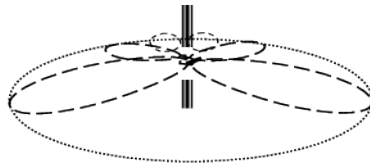

- Typically using Colinear Vertical stack.
- Antenna Gain : 8 to 15dBi
- Easy installation.
- Inexpensive.

### Sectorization at AP side

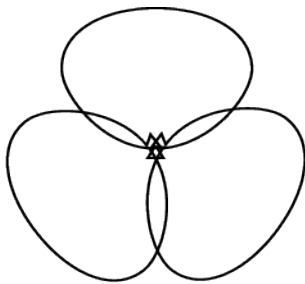

- Using vertically stacked patch or dipole with reflector.
- Antenna Gain : 10 to 20dBi
- Need to administrate the sector # entry in ACL table.
- Not expensive but need the sector selection switch.
- Interference on co existing network can be reduced.

## AP side Antenna Diversity option (Rx)

### Selection Diversity of Redundant Receivers using Multiple Antenna

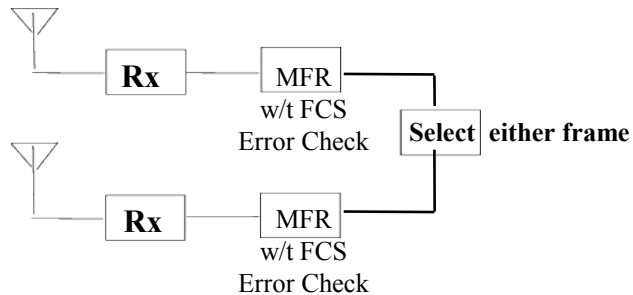

•Relatively simple

•Spatial Diversity (Two co-located Rx)

•Much better than Antenna Selection by RSSI

### Selection Diversity of Fragmented Frames using Multiple Receiver chains

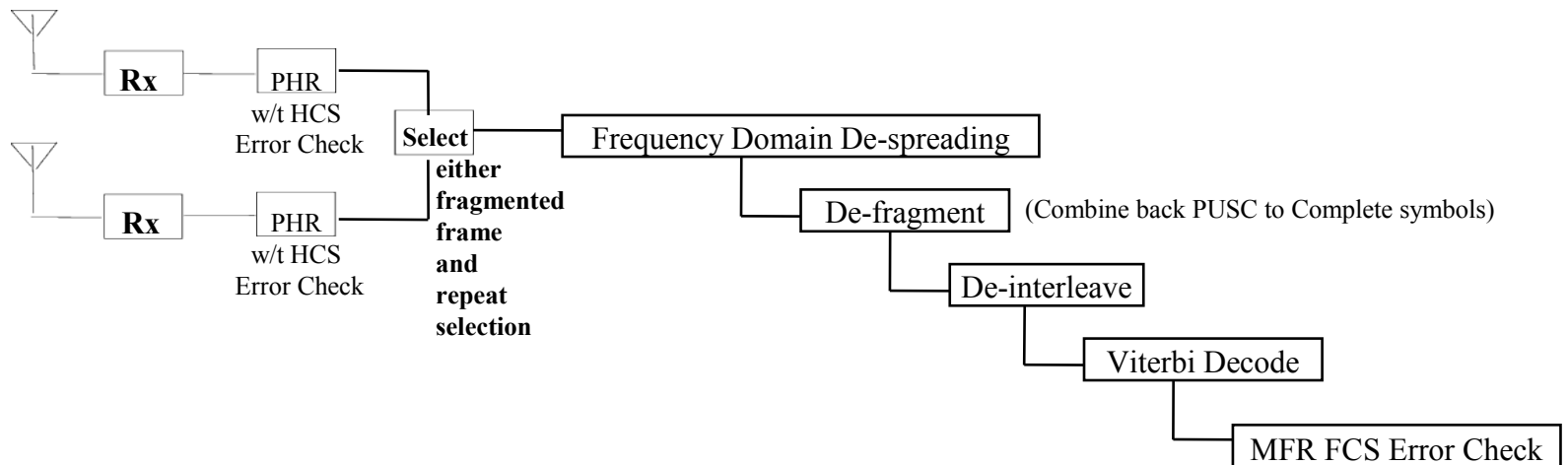

## AP side Antenna Diversity option (Tx)

### Transmit Selection Diversity using Multiple Antenna

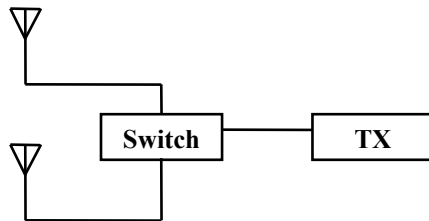

- Relatively simple
- Assuming channel reciprocity (by co-located Rx)
- Much simpler than other Tx diversity

### Transmit Diversity using CDD (Cyclic Delay Diversity) by Multiple Transceiver chains

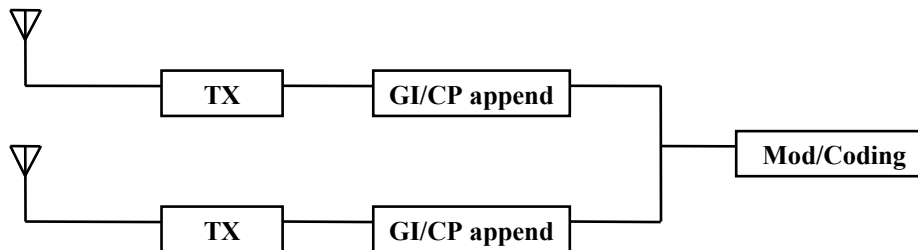

- Much simpler than other Tx beamforming

# PUSC Diversity and 15.4g MR-OFDM Frequency Spreading

## Frequency Spreading scheme of 15.4g OFDM

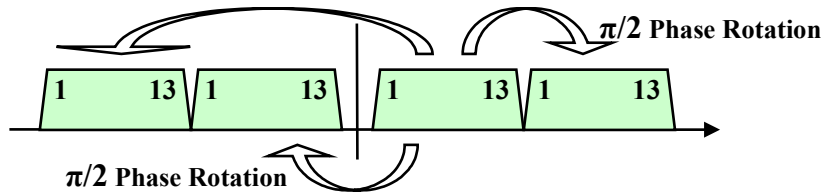

## Sufficient order of Diversity

In case of option 2 , all 4 by 4 matrix elements are able to select and combine to decode.  
 (In case of option 1, more than 4 by 4 but much less than 8 by 4 elements are available.)

## PUSC Symbol Repetition with 15.4g MR-OFDM FS

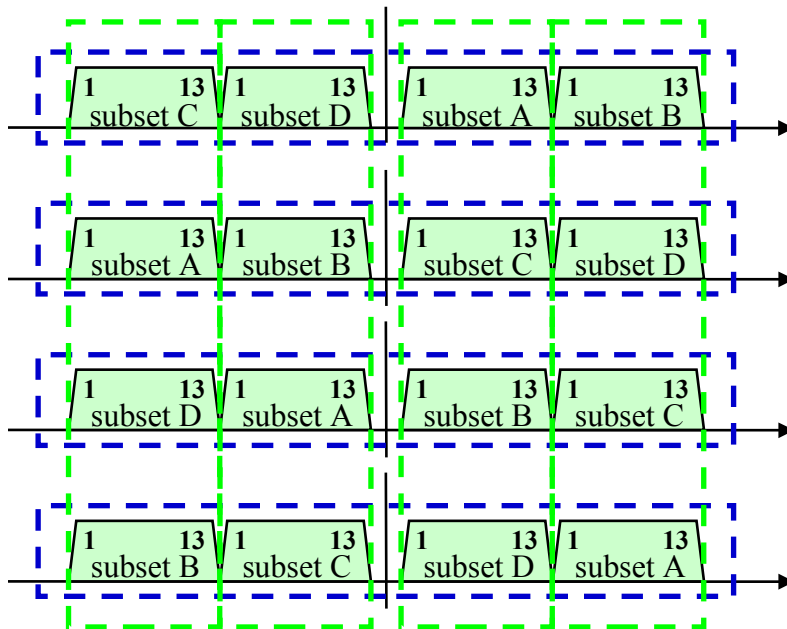

## Option 2 of 15.4g MR-OFDM

$$4 + 6 \times \Sigma (4,6,,4) + 4 \times \Sigma_3(4 \times 3 \times 1) + 4 \times 3 \times 2 \times 1 = 256$$

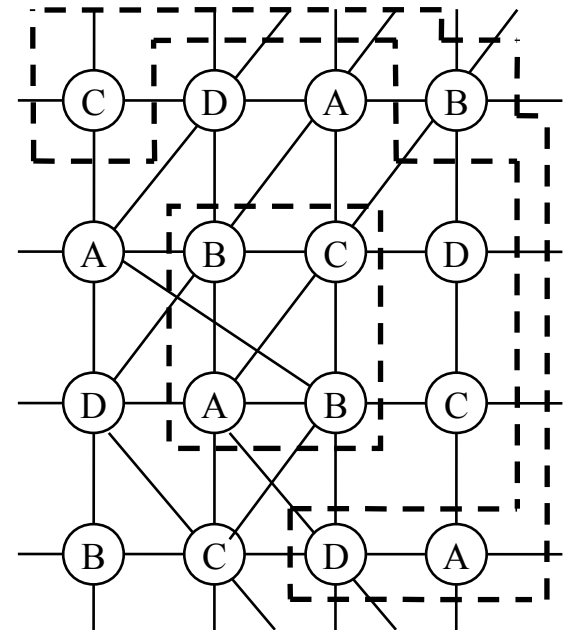

## Simple Utilization of PUSC Diversity at Rx on Sensor nodes

Treat as Virtual Re-transmission in case that the depth of interleaver is set to a symbol length.

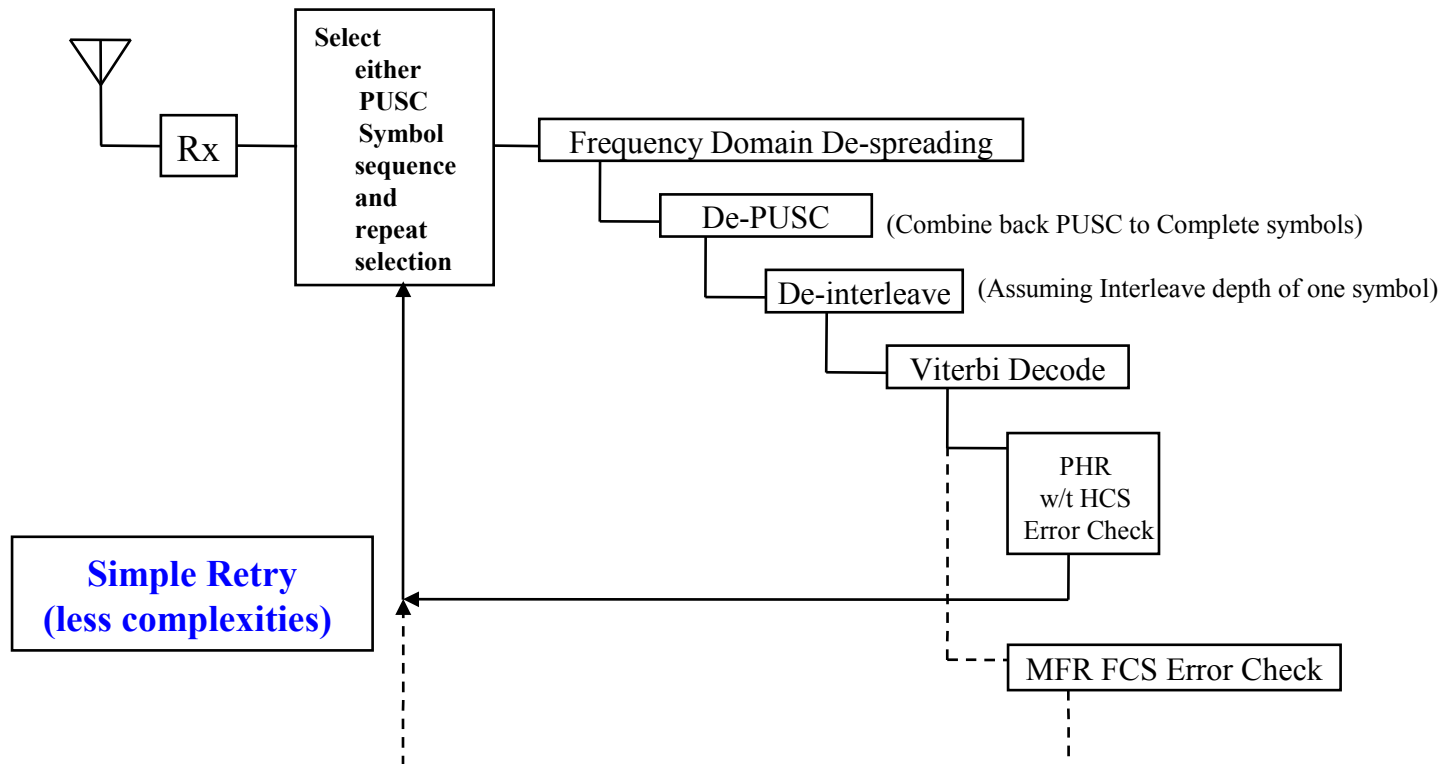

# Slow Frequency Channel Agility of 15.4e and PUSC PHY fragmentation

PUSC Symbol Repetition with 15.4g MR-OFDM FS

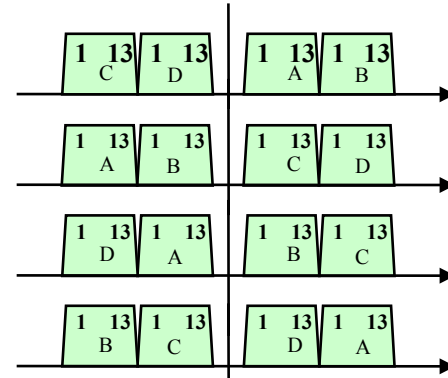

Each fragmented PUSC Symbols transmitted on different channels managed by 15.4e frequency agility  
 Fragmented PUSC Symbols received on different channels are to managed to combine back for decoding

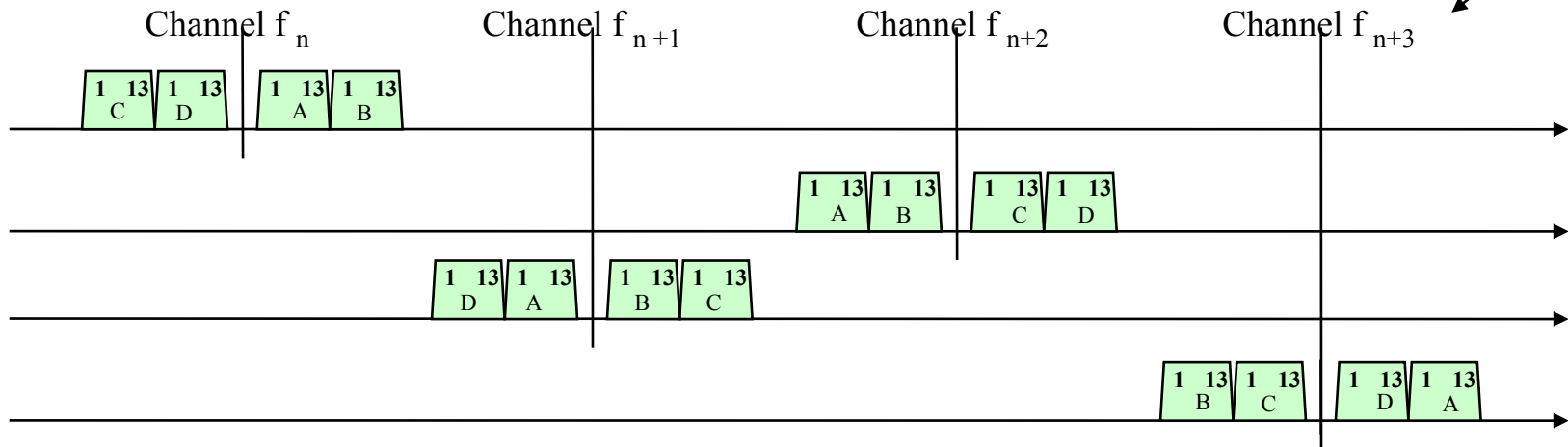

## Random PUSC structure of LECIM-MR-OFDM for interference gain

- Following slides show the images of signal spectrum of random-spaced PUSC scheme.

(Actual spectrum are observed associated side lobes in term of each SC.)

- One of pros of random-spaced PUSC is less interfere to other systems than equi-spaced PUSC, if many co-existing systems exist.
- Cons of random-spaced PUSC include, (1) less diversity re-combination, (2) not so random in case of number of sub-carriers is not large, and (3) complexities.



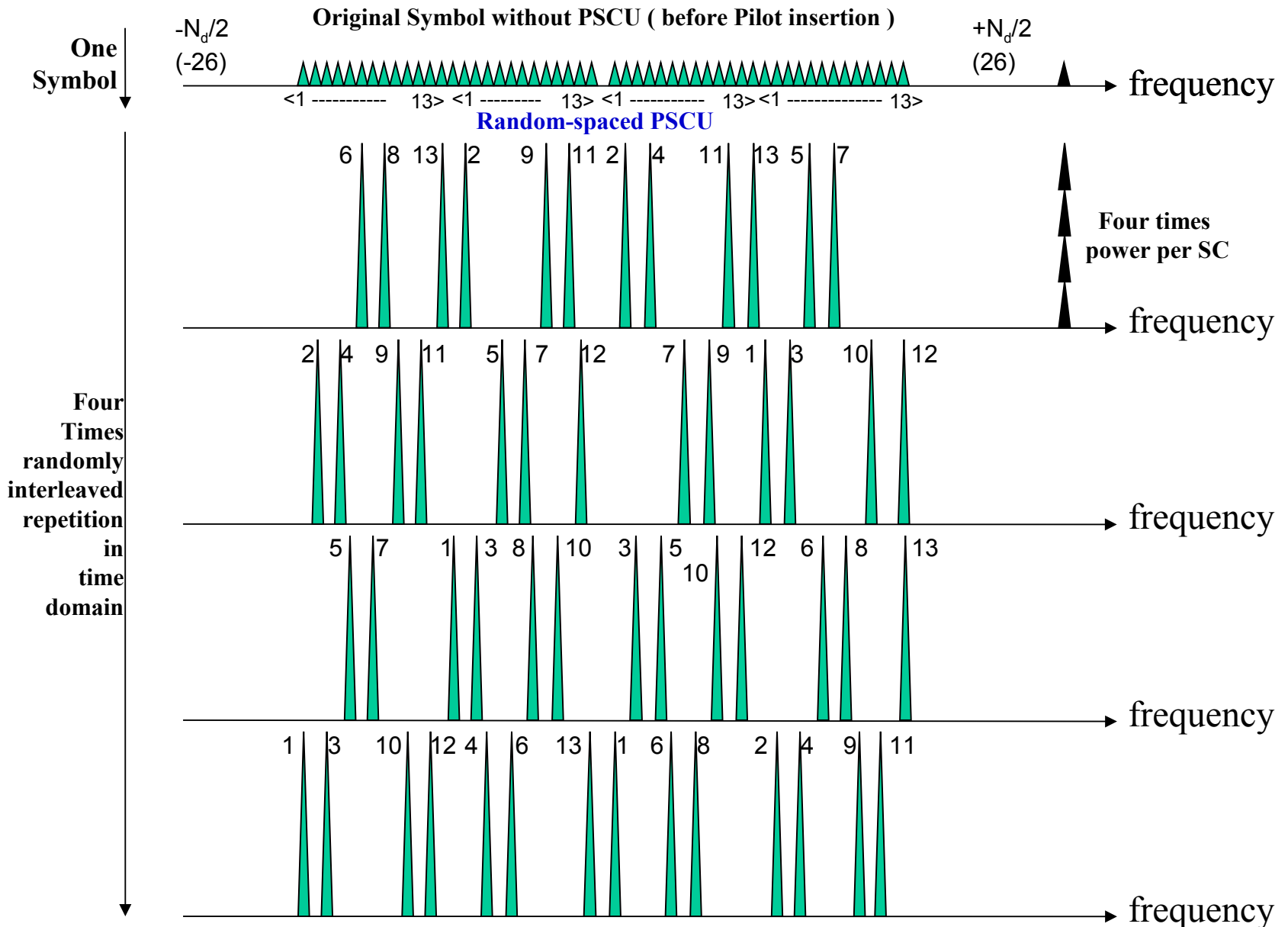

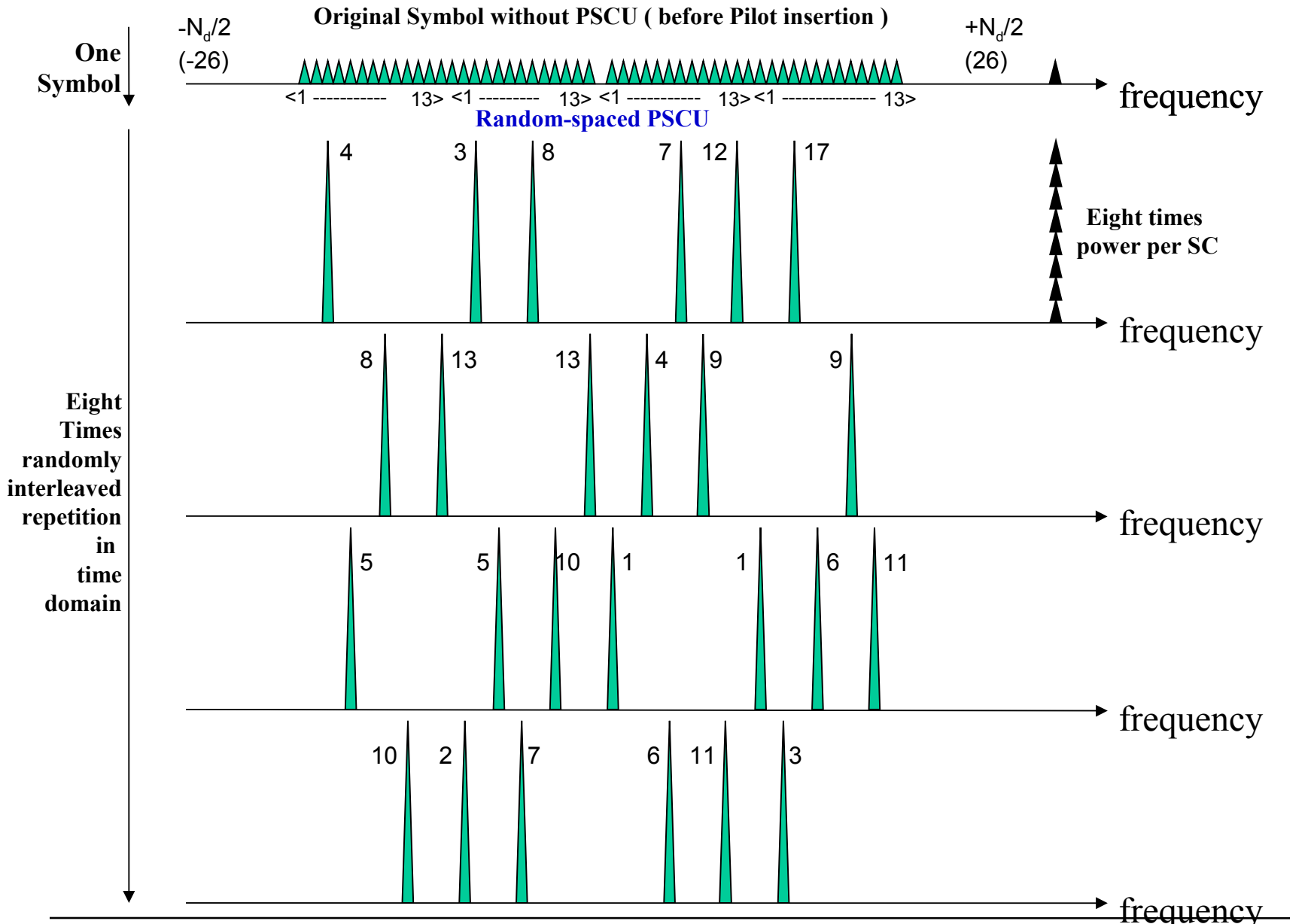

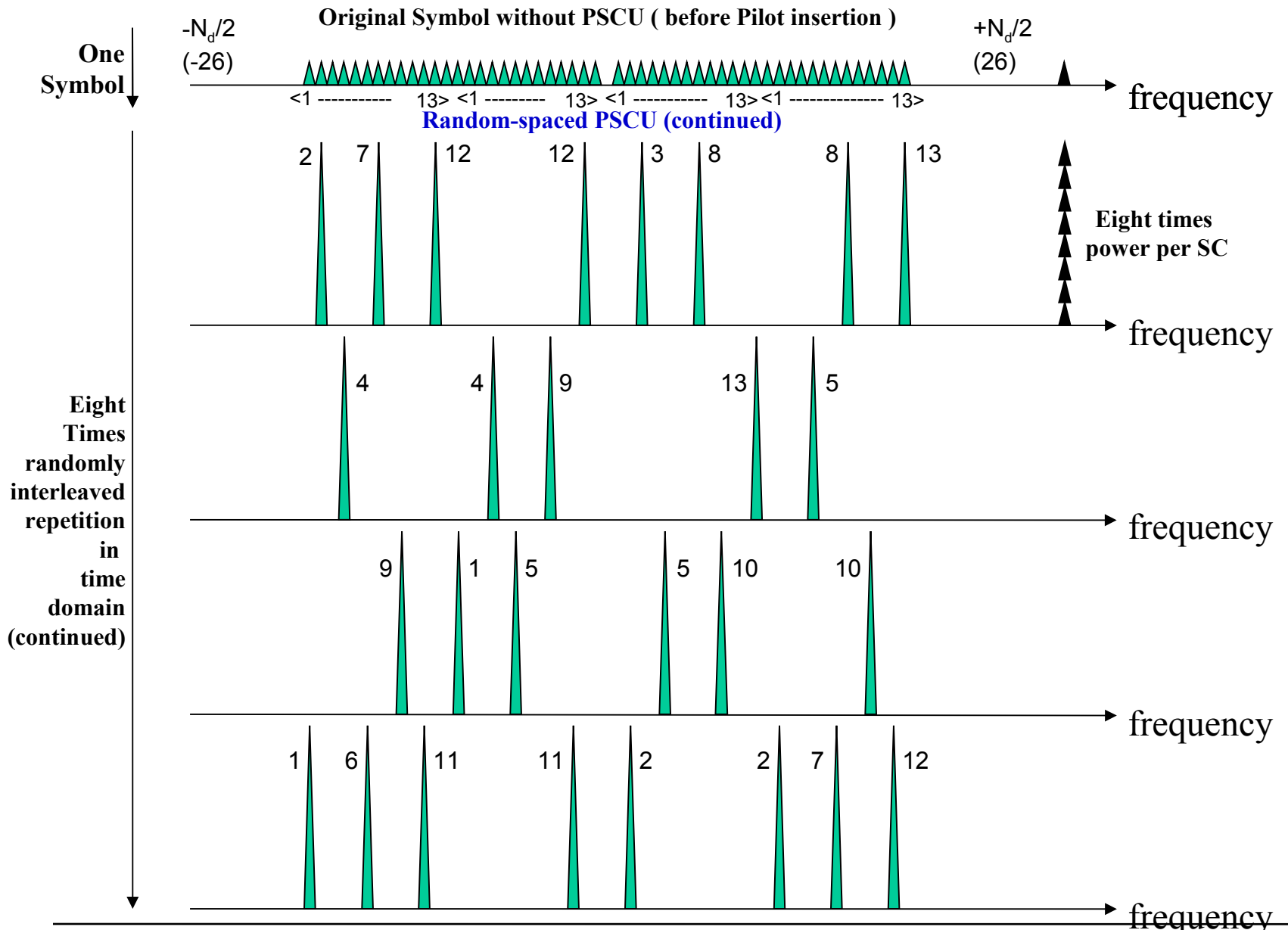

## Reinforcing synchronization opportunity using repetition of STF

- Original STF repetitions of 15.4g MR-OFDM are increased in accordance with PUSC spreading factors, i.e. two, four or eight times, to facilitate capturing the periodicity within SHR for rough synchronization.

( Time domain and frequency domain correlation property is unchanged. )

- Other than STF repetition, (1) STF element, (2) LTF, (3) Pilots and its insertion are not changed as is in 15.4g MR-OFDM.
- Compatibility of PHR with existing MR-OFDM is still open issue.

### Structure of STF Repetition for LECIM-MR-OFDM for Option 1,2

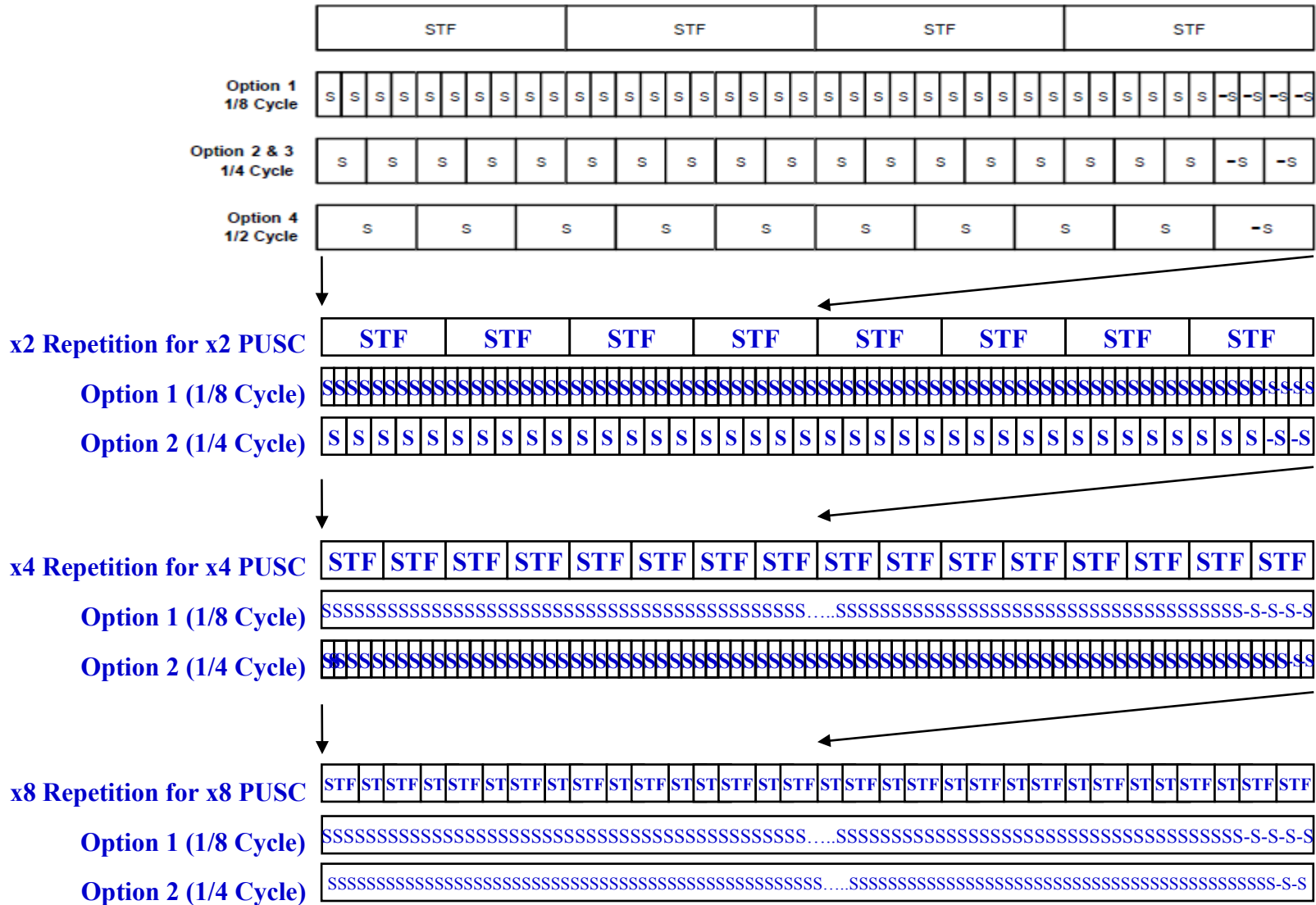

Frequency domain representation of Option 1 STF\_freq(0)

Tone#	Value	Tone#	Value	Tone#	Value	Tone#	Value
-64	0	-32	-2.9439	0	0	32	2.9439
-63	0	-31	0	1	0	33	0
-62	0	-30	0	2	0	34	0
-61	0	-29	0	3	0	35	0
-60	0	-28	0	4	0	36	0
-59	0	-27	0	5	0	37	0
-58	0	-26	0	6	0	38	0
-57	0	-25	0	7	0	39	0
-56	0	-24	2.9439	8	2.9439	40	-2.9439
-55	0	-23	0	9	0	41	0
-54	0	-22	0	10	0	42	0
-53	0	-21	0	11	0	43	0
-52	0	-20	0	12	0	44	0
-51	0	-19	0	13	0	45	0
-50	0	-18	0	14	0	46	0
-49	0	-17	0	15	0	47	0
-48	-2.9439	-16	2.9439	16	-2.9439	48	2.9439
-47	0	-15	0	17	0	49	0
-46	0	-14	0	18	0	50	0
-45	0	-13	0	19	0	51	0
-44	0	-12	0	20	0	52	0
-43	0	-11	0	21	0	53	0
-42	0	-10	0	22	0	54	0
-41	0	-9	0	23	0	55	0
-40	-2.9439	-8	2.9439	24	2.9439	56	0
-39	0	-7	0	25	0	57	0
-38	0	-6	0	26	0	58	0
-37	0	-5	0	27	0	59	0
-36	0	-4	0	28	0	60	0
-35	0	-3	0	29	0	61	0
-34	0	-2	0	30	0	62	0
-33	0	-1	0	31	0	63	0

Frequency domain representation of Option 2 STF\_freq(1)

Tone#	Value	Tone#	Value	Tone#	Value	Tone#	Value
-32	0	-16	-2.0817	0	0	16	2.0817
-31	0	-15	0	1	0	17	0
-30	0	-14	0	2	0	18	0
-29	0	-13	0	3	0	19	0
-28	0	-12	2.0817	4	2.0817	20	-2.0817
-27	0	-11	0	5	0	21	0
-26	0	-10	0	6	0	22	0
-25	0	-9	0	7	0	23	0
-24	-2.0817	-8	2.0817	8	-2.0817	24	2.0817
-23	0	-7	0	9	0	25	0
-22	0	-6	0	10	0	26	0
-21	0	-5	0	11	0	27	0
-20	-2.0817	-4	2.0817	12	2.0817	28	0
-19	0	-3	0	13	0	29	0
-18	0	-2	0	14	0	30	0
-17	0	-1	0	15	0	31	0

STF symbol is not changed

Structure of LTF for MR-OFDM

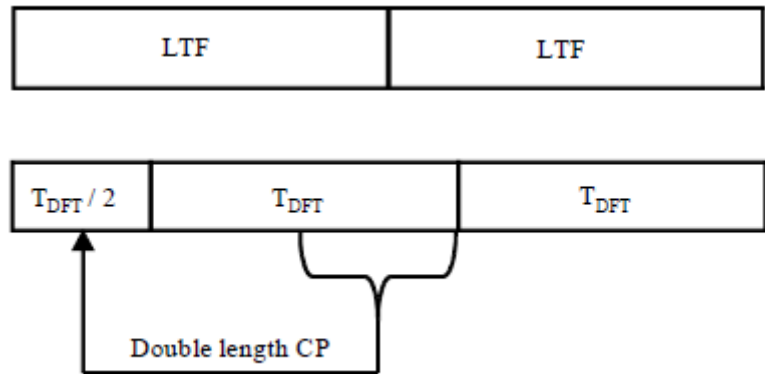

**LTF is not changed**

Frequency domain representation of Option 1 LTF\_freq(0)

Tone#	Value	Tone#	Value	Tone#	Value	Tone#	Value
-64	0	-32	-1	0	0	32	-1
-63	0	-31	-1	1	1	33	-1
-62	0	-30	-1	2	-1	34	-1
-61	0	-29	1	3	1	35	1
-60	0	-28	1	4	-1	36	1
-59	0	-27	-1	5	1	37	1
-58	0	-26	-1	6	1	38	1
-57	0	-25	-1	7	-1	39	1
-56	0	-24	-1	8	-1	40	1
-55	0	-23	-1	9	1	41	-1
-54	0	-22	1	10	-1	42	-1
-53	0	-21	1	11	1	43	-1
-52	-1	-20	-1	12	1	44	-1
-51	1	-19	1	13	1	45	-1
-50	1	-18	-1	14	1	46	-1
-49	-1	-17	-1	15	-1	47	1
-48	-1	-16	1	16	1	48	-1
-47	-1	-15	-1	17	1	49	1
-46	-1	-14	1	18	1	50	1
-45	1	-13	1	19	1	51	-1
-44	1	-12	1	20	1	52	1
-43	-1	-11	1	21	-1	53	0
-42	-1	-10	-1	22	1	54	0
-41	1	-9	-1	23	-1	55	0
-40	1	-8	1	24	1	56	0
-39	1	-7	1	25	-1	57	0
-38	-1	-6	-1	26	1	58	0
-37	-1	-5	1	27	-1	59	0
-36	1	-4	1	28	1	60	0
-35	1	-3	-1	29	1	61	0
-34	-1	-2	1	30	-1	62	0
-33	-1	-1	1	31	1	63	0

Frequency domain representation of Option 2 LTF\_freq(1)

Tone#	Value	Tone#	Value	Tone#	Value	Tone#	Value
-32	0	-16	1	0	0	16	1
-31	0	-15	-1	1	1	17	-1
-30	0	-14	1	2	-1	18	-1
-29	0	-13	1	3	1	19	-1
-28	0	-12	-1	4	1	20	-1
-27	0	-11	-1	5	-1	21	-1
-26	-1	-10	-1	6	1	22	1
-25	-1	-9	1	7	-1	23	-1
-24	-1	-8	1	8	-1	24	-1
-23	-1	-7	-1	9	1	25	-1
-22	1	-6	1	10	-1	26	1
-21	1	-5	1	11	1	27	0
-20	1	-4	1	12	1	28	0
-19	-1	-3	-1	13	-1	29	0
-18	1	-2	-1	14	-1	30	0
-17	-1	-1	-1	15	1	31	0

LTF symbol is not changed



### PHY header fields for MR-OFDM

Bit string index	0-4	5	6-16	17-18	19-20	21	22-29	30-35
Bit mapping	RA <sub>4</sub> -RA <sub>0</sub>	R	L <sub>10</sub> -L <sub>0</sub>	R <sub>1</sub> -R <sub>0</sub>	S <sub>1</sub> -S <sub>0</sub>	R	H <sub>7</sub> -H <sub>0</sub>	T <sub>5</sub> -T <sub>0</sub>
Field name	Rate	Reserved	Frame Length	Reserved	Scrambler	Reserved	HCS	Tail

**PHR Modulation : BPSK 1/2 rate coded, 4x frequency spreading and 4x PUSC**

← Open issue  
(15.4g Compatibility)

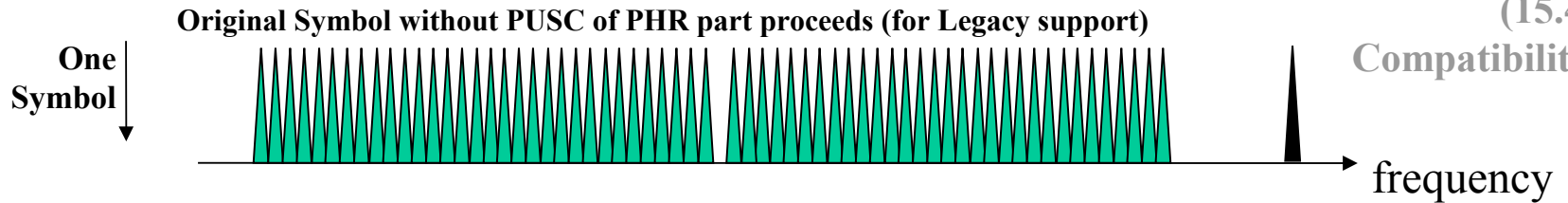

**After original PHR without PHR extension part even if fragmented, iterative PHR using Equi-spaced PSCU with PHR extension follows if fragmented.**

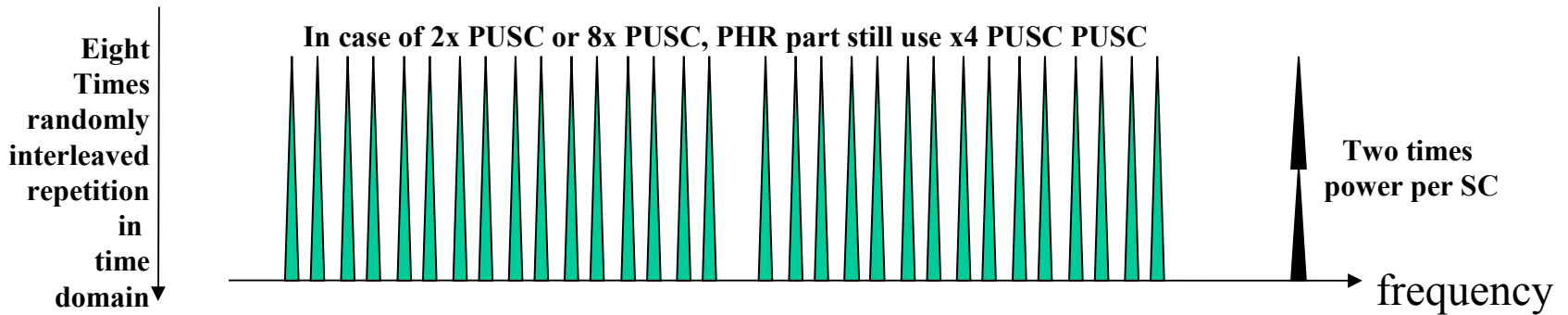

## Samples of Link Budget

- Instead of using higher Tx power (e.g. 30dBm output) at AP (collector), higher antenna gain at AP is assumed. This may enhance the world wide commonality.

### LECIM-MR-OFDM 900MHz ( 920MHz ) Band Link Budget (Based on Okumura Hata Model)

Parameter	unit	Large City	Medium City	Suburban	Open Space
		Sensor to AP Large Urban	Sensor to AP Small Urban	Sensor to AP Suburban	Sensor to AP Rural (Open Site)
Frequency	MHz	920	920	920	920
Distance	m	800	1000	2000	16000
AP Antenna Height	m	20	15	10	50
STA Antenna Height	m	2	2	2	2
Okumura Hata (A+B*LOG(d)+C)					
A		129.10	130.83	133.26	123.60
B		36.38	37.20	38.35	33.77
C		-1.05	-1.30	-11.05	-29.65
RX Antenna Gain (AP)	dBi	12	12	12	12
Total Path Loss (L)	dB	124.53	129.53	133.76	134.62
Shadowing	dB	12.00	7.00	3.00	2.00
Path Loss + Shadowing	dB	136.53	136.53	136.76	136.62
Tx Power (STA)	dBm	13	13	13	13
Tx Antenna Gain (STA)	dBi	3	3	3	3
Received Signal Power(RSS)	dBm	-108.53	-108.53	-108.76	-108.62
NF+Implementation	dB	5	5	5	5
N <sub>total</sub>	dBm	-169.00	-169.00	-169.00	-169.00
BW	kHz	800	800	800	800
Total (N)	dBm	-110.0	-110.0	-110.0	-110.0
Assumed SNR (RSS/N)	dB	1.0	1.0	1.0	1.0
Superficial Link Margin (Including Fading)	dB	0.4	0.4	0.2	0.3
Substantial Margin RSS/Sensitivity(-114dBm)	dB	5.5	5.5	5.2	5.4

### LECIM-MR-OFDM 900MHz ( 920MHz ) Required Eb/No (Based on Okumura Hata Model)

Parameter	unit	Large City	Medium City	Suburban	Open Space
		Sensor to AP Large Urban	Sensor to AP Small Urban	Sensor to AP Suburban1	Sensor to AP Rural (Open Site)
Frequency	MHz	920	920	920	920
Distance	m	800	1000	2000	16000
AP Antenna Height	m	20	15	10	50
STA Antenna Height	m	2	2	2	2
Okumura Hata (A+B*LOG(d)+C)					
A		129.10	130.83	133.26	123.60
B		36.38	37.20	38.35	33.77
C		-1.05	-1.30	-11.05	-29.69
RX Antenna Gain (AP)	dBi	12	12	12	12
Total Path Loss (L)	dB	124.53	129.53	133.76	134.58
Shadowing	dB	12.00	7.00	3.00	2.00
Path Loss + Shadowing	dB	136.53	136.53	136.76	136.58
Tx Power (STA)	dBm	13	13	13	13
Tx Antenna Gain (STA)	dBi	3	3	3	3
Received Signal Power(RSS)	dBm	-108.53	-108.53	-108.76	-108.58
NF+Implementation	dB	5	5	5	5
No	dBm	-169.00	-169.00	-169.00	-169.00
BW	kHz	800	800	800	800
Total (N)	dBm	-110.0	-110.0	-110.0	-110.0
Data Rate	kbps	6.25	6.25	6.25	6.25
Eb	dBm	-146.49	-146.49	-146.72	-146.54
Fading Margin (only for E/No calculation)	dB	15.00	15.00	15.00	15.00
Eb/No	dB	7.51	7.51	7.28	7.46

### LECIM-MR-OFDM 2400MHz Band Link Budget (Based on COST231 Hata Model & Erceg Model)

		Large City	Hilly	Mid-Hilly/Flat	Flat
Frequency	MHz	2400	2400	2400	2400
Distance	m	300	1600	1600	8000
AP Antenna Height	m	20	15	10	50
STA Antenna Height	m	2	2	2	2
Okumura Hata (A+B*LOG(d)+C)					
A		142.91	55.16	55.16	55.16
B		36.38	53.28	56.45	37.50
C		1.95	10.60	9.60	8.20
RX Antenna Gain (AP)	dBi	12	12	12	12
Total Path Loss (L)	dB	125.84	129.91	132.74	134.73
Shadowing	dB	12.00	7.00	3.00	2.00
Path Loss + Shadowing	dB	137.84	136.91	135.74	136.73
Tx Power (STA)	dBm	13	13	13	13
Tx Antenna Gain (STA)	dBi	3	3	3	3
Received Signal Power(RSS)	dBm	-109.84	-108.91	-107.74	-108.73
NF+Implementation	dB	5	5	5	5
N <sub>total</sub>	dBm	-169.00	-169.00	-169.00	-169.00
BW	kHz	800	800	800	800
Total (N)	dBm	-110.0	-110.0	-110.0	-110.0
Assumed SNR (RSS/N)	dB	1.0	1.0	1.0	1.0
Superficial Link Margin (Including Fading)	dB	-0.9	0.1	1.2	0.2
Substantial Link Margin RSS/Sensitivity(-114dBm)	dB	4.2	5.1	6.3	5.3

### LECIM-MR-OFDM 2400MHz Band Link Budget (Based on COST231 Hata Model & Erceg Model)

Parameter	unit	Large City	Hilly	Mid-Hilly/Flat	Flat
		Sensor to AP Large Urban	Sensor to AP Mid-city/Suburban	Sensor to AP Suburbanl	Sensor to AP Rural (Open Site)
Frequency	MHz	2400	2400	2400	2400
Distance	m	300	1600	1600	8000
AP Antenna Height	m	20	15	10	50
STA Antenna Height	m	2	2	2	2
Okumura Hata (A+B*LOG(d)+C)					
A		142.91	55.16	55.16	55.16
B		36.38	53.28	56.45	37.50
C		1.95	10.60	9.60	8.20
RX Antenna Gain (AP)	dBi	12	12	12	12
Total Path Loss (L)	dB	125.84	129.91	132.74	134.73
Shadowing	dB	12.00	7.00	3.00	2.00
Path Loss + Shadowing	dB	137.84	136.91	135.74	136.73
Tx Power (STA)	dBm	13	13	13	13
Tx Antenna Gain (STA)	dBi	3	3	3	3
Received Signal Power(RSS)	dBm	-109.84	-108.91	-107.74	-108.73
NF+Implementation	dB	5	5	5	5
No	dBm	-169.00	-169.00	-169.00	-169.00
BW	kHz	800	800	800	800
Total (N)	dBm	-110.0	-110.0	-110.0	-110.0
Data Rate	kbps	6.25	6.25	6.25	6.25
Eb	dBm	-147.80	-146.87	-145.69	-146.69
Fading Margin (only for E/No calculation)	dB	15.00	15.00	15.00	15.00
Eb/No	dB	6.20	7.13	8.31	7.31

# LECIM-DSSS-PSK

## Purpose of LECIM-DSSS-PSK extension

- Existing DSSS-PSK chip rate repertoire of current 15.4 is including,
  - (1) Chip rate of 100Kcps with FEC and several optional data rates for narrower available channels in various regional bands above 470MHz,
  - (2) Chip rate of 1M/2Mcps with FEC and several optional data rates for sufficiently wider channels within international 2.4GHz band, 915MHz US ISM band and Chinese 783MHz band.
  - (3) Chip rates between 100KHz and 1MHz without FEC and with fixed single data rate for sub 1GHz band (800MHz ~ 1GHz), including Japanese obsolete 950MHz.
- The purpose of proposing LECIM-DSSS-PSK extension is to append a few chip rates between 100KHz and 1MHz with FEC and several optional data rates using different spreading factors which properly fulfill 15.4k requirements.
- Simultaneously, each technical element constructing this extension is selected from existing building blocks of 15.4 Std. in order to facilitate the design of multiple modes VLSI and legacy compatibility.



## General structure of LECIM-DSSS-PSK scheme

- A few Chip rates between 100Kcps and 1Mcps should be appended with FEC and variable spreading factor to be used in the channel spacing between 600KHz and 1MHz.
- Chip rates : 300K and 500Kcps (Open to discuss about other rates)
- Modulation scheme could be OQPSK (BPSK) with optional spreading factor of 2/4/8/16/32 using same m-sequences as 15.4g.
- Corresponding data rates are,  
(1) For 300Kcps: 75/37.5/18.75/9.375/4.6875Kbps  
(2) For 500Kbps: 250/125/62.5/31.25/15.625Kbps
- Convolutional Code:  $r=1/2$   $k=7$  {133, 171} with interleaver.

## Link resource allocation and management based on Slower Channel Agility

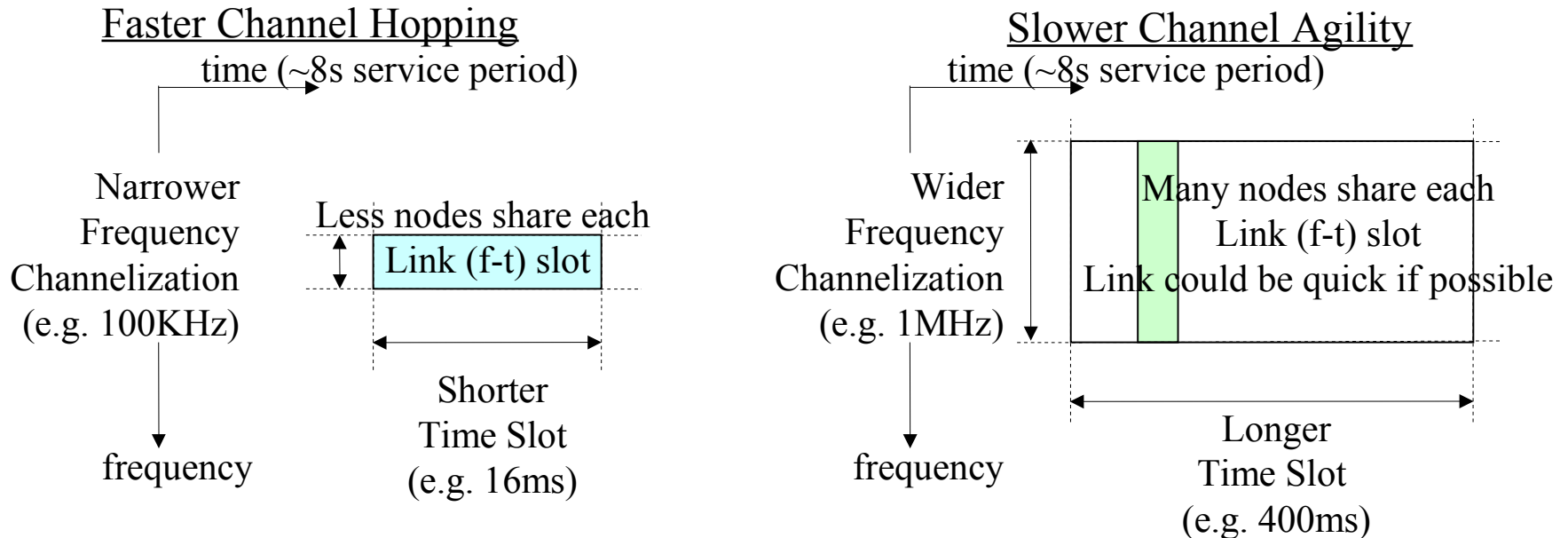

- **8 co-existing network with more than 1000 nodes each > 10000 nodes**
  - 10000 nodes have to share the frequency and time (or code) resource.
- **CSMA type sharing of link (f-t) slot may facilitate the management.**
  - **Variable Data rate adaptation using SF** and relaying still maintain network resiliency. (OFDM-PUSC and DSSS-PSK)

## Minimum DS-PSK Extension on IEEE802.15.4x Existing PHY

Std 15.	Modulation Scheme	Data Rates	Channel Spacing	FEC / Interleaver	Rx Sensitivity 10%/250octet (w/t FEC)	Remarks
4i	DS-OQPSK	100kbps	600kHz	No	-85dBm(1%/20octet) w/o FEC	400kcps(25ksymbol/s)
4i	DS-OQPSK	250kbps	2MHz	No	-85dBm(1%/20octet) w/o FEC	1Mcps(62.5ksymbol/s)
4i	DS-OQPSK	250kbps	5MHz	No	-85dBm(1%/20octet) w/o FEC	2Mcps(62.5ksymbol/s)
4i	DS-BPSK	20k/40kbs	600kHz/2MHz	No	-92dBm(1%/20octet) w/o FEC	300kcps/600kcps
4g	DS-OQPSK	31.25k/62.5/125/250/500kbps	2MHz/5MHz	PHR:60bit/PDU:126bit	-110/-105/-100/-95/-90dBm	1Mcps/2Mcps
4g	DS-OQPSK	6.25/12.5/25k/50kbps	200kHz	PHR:60bit/PDU:126bit	-110/-105/-100/-95/-90dBm	100kcps
4f	MSK	31.25k/250kbps	60kHz/580kHz	No		
4i	GFSK	100kbps	400kHz	No	-85dBm(1%/20octet) w/o FEC	for 4d Japan sub-1G
4g	(Filter) FSK	4.8/9.6kbps	12.5kHz	Option/16symbols	-97dBm+10log(R/50kbps)	for US450-470MHz
4g	(Filter) FSK	10/20/40kbps	12.5kHz	Option/16symbols	-97dBm+10log(R/50kbps)	for US928-960MHz
4g	(Filter) FSK	100kbps/150kbps/200kbps	400kHz	Option/16symbols	-97dBm+10log(R/50kbps)	
4g	(Filter) FSK	400kbps	600kHz	Option/16symbols	-97dBm+10log(R/50kbps)	
4g	OFDM	50/100/150/200/300kbps	200kHz	1symbol/xSF(upto192bit)	-105/-103/-100/-97/-94dBm	16DFT(14tones)
4g	OFDM	50/100/200/300/400/600kbps	400kHz	1symbol/xSF	-105/-103/-100/-97/-94/-91dBm	32DFT(26tones)
4g	OFDM	50/100/200/400/600/800kbps	800kHz	1symbol/xSF	-105/-103/-100/-97/-94/-91dBm	64DFT(52tones)
4g	OFDM	100/200/400/800kbps	1.2MHz	1symbol/xSF	-103/-100/-97/-94dBm	128DFT(104tones)

## LECIM DSSS-PSK PHY Parameters

Parameters	Value		Remarks
Chip Rate	300Kcps	500Kcps	Open to discuss in term of 200 and 400Kcps
Data Rate & (SF)	37.5K (4) 18.75K (8) 9.375K (16) 4.6875K (32)	31.25Kbps (8) 15.625Kbps (16) 7.8125Kbps (32) 3.90625Kbps (64)	
Convolutional Code	K=7, 1/2 rate Std. code		Existing 15.4 FEC $1+x+x^2+x^3+x^6/1+x^2+x^3+x^5+x^6$
Interleaver	PHR 60bit PDU 126bit		Existing 15.4 Interleaver
Primary Modulation	OQPSK (BPSK)		With BDE Optional coherent detection
SHR Length	Proportional to SF		Under consideration
Channel Spacing	800KHz (600KHz) / 1MHz		600KHz for EU 868.3MHz
Legacy Compatibility	No		But possible dual mode VLSI chip with DSSS-DBPSK (15.4i )

## LECIM DSSS-PSK PHY Block Diagram

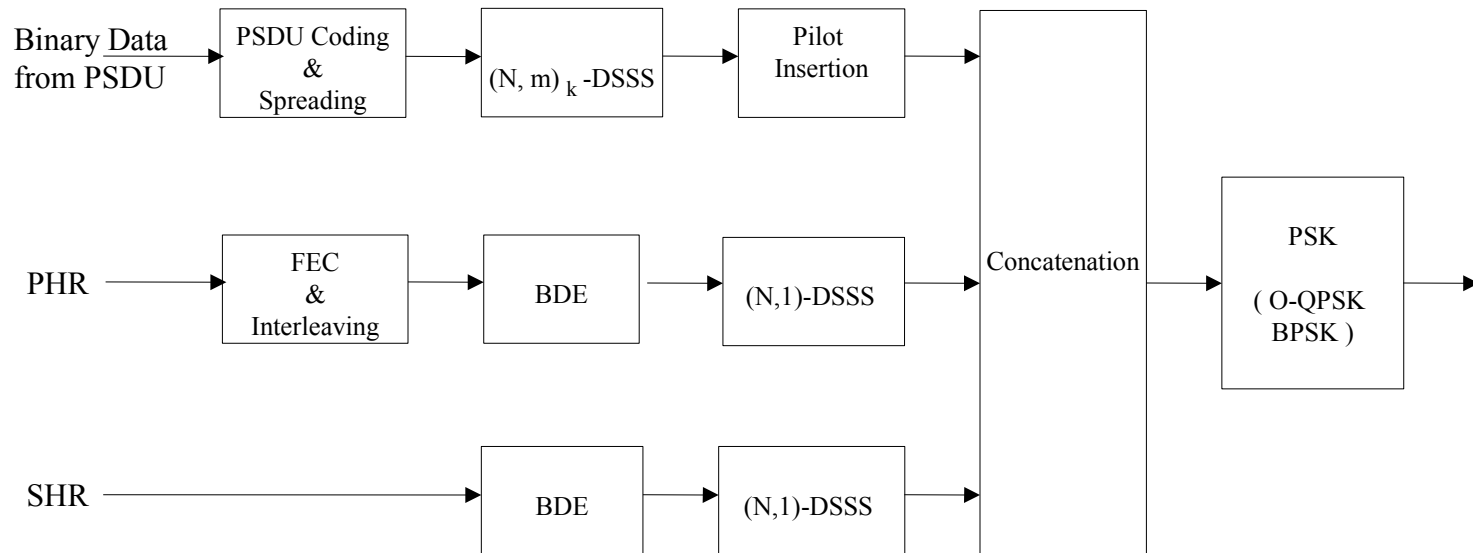

Almost same as existing 15.4g MR-OQPSK

## Receiver Sensitivity

Chip rate	Rate Mode 0	Rate Mode 1	Rate Mode 2	Rate Mode 3
300Kcps (SF)	-111dBm (32)	-108dBm (16)	-105dBm (8)	-100dBm (4)
500Kcps (SF)	-111dBm (64)	-108dBm (32)	-105dBm (16)	-100dBm (8)
Remarks	Above estimations are based on the required sensitivities of existing 15.4g MR-OQPSK scheme and open to discuss, if they are overly conservative.			

## Samples of Link Budget

- Instead of using higher Tx power (e.g. 30dBm output) at AP (collector), higher antenna gain at AP is assumed. This may enhance the world wide commonality.

### LECIM-MR-PSK 300kps/800KHz ( 920MHz ) Band Link Budget (Based on Okumura Hata Model)

Parameter	unit	Large City	Medium City	Suburban	Open Space
		Sensor to AP Large Urban	Sensor to AP Small Urban	Sensor to AP Suburbanl	Sensor to AP Rural (Open Site)
Frequency	MHz	920	920	920	920
Distance	m	800	1000	2000	16000
AP Antenna Height	m	20	15	10	50
STA Antenna Height	m	2	2	2	2
Okumura Hata (A+B*LOG(d)+C)					
A		129.10	130.83	133.26	123.60
B		36.38	37.20	38.35	33.77
C		-1.05	-1.30	-11.05	-29.65
RX Antenna Gain (AP)	dBi	12	12	12	12
Total Path Loss (L)	dB	124.53	129.53	133.76	134.62
Shadowing	dB	12.00	7.00	3.00	2.00
Path Loss + Shadowing	dB	136.53	136.53	136.76	136.62
Tx Power (STA)	dBm	13	13	13	13
Tx Antenna Gain (STA)	dBi	3	3	3	3
Received Signal Power(RSS)	dBm	-108.53	-108.53	-108.76	-108.62
NF+Implementation	dB	5	5	5	5
N <sub>total</sub>	dBm	-169.00	-169.00	-169.00	-169.00
BW	kHz	800	800	800	800
Total (N)	dBm	-110.0	-110.0	-110.0	-110.0
Assumed SNR (RSS/N)	dB	1.0	1.0	1.0	1.0
Superficial Link Margin (Including Fading)	dB	0.4	0.4	0.2	0.3
Substantial Margin RSS/Sensitivity(-111dBm)	dB	2.5	2.5	2.2	2.4



**LECIM-MR-PSK 300Kcps/800KHz ( @ 920MHz ) Required Eb/No (Based on Okumura Hata Model)**

Parameter	unit	Large City	Medium City	Suburban	Open Space
		Sensor to AP Large Urban	Sensor to AP Small Urban	Sensor to AP Suburbanl	Sensor to AP Rural (Open Site)
Frequency	MHz	920	920	920	920
Distance	m	800	1000	2000	16000
AP Antenna Height	m	20	15	10	50
STA Antenna Height	m	2	2	2	2
Okumura Hata (A+B*LOG(d)+C)					
A		129.10	130.83	133.26	123.60
B		36.38	37.20	38.35	33.77
C		-1.05	-1.30	-11.05	-29.69
RX Antenna Gain (AP)	dBi	12	12	12	12
Total Path Loss (L)	dB	124.53	129.53	133.76	134.58
Shadowing	dB	12.00	7.00	3.00	2.00
Path Loss + Shadowing	dB	136.53	136.53	136.76	136.58
Tx Power (STA)	dBm	13	13	13	13
Tx Antenna Gain (STA)	dBi	3	3	3	3
Received Signal Power(RSS)	dBm	-108.53	-108.53	-108.76	-108.58
NF+Implementation	dB	5	5	5	5
No	dBm	-169.00	-169.00	-169.00	-169.00
BW	kHz	800	800	800	800
Total (N)	dBm	-110.0	-110.0	-110.0	-110.0
Data Rate	kbps	4.7	4.7	4.7	4.7
Eb	dBm	-145.25	-145.25	-145.48	-145.30
Fading Margin (only for E/No calculation)	dB	15.00	15.00	15.00	15.00
Eb/No	dB	8.75	8.75	8.52	8.70

### LECIM-MR-PSK 500Kcps/1MHz (@ 2400MHz ) Link Budget (Based on COST231 Hata Model & Erceg Model)

Parameter	unit	Large City	Hilly	Mid-Hilly/Flat	Flat
		Sensor to AP Large Urban	Sensor to AP Terrain A	Sensor to AP Terrain B	Sensor to AP Rural (Flat)
Frequency	MHz	2400	2400	2400	2400
Distance	m	300	1600	1600	8000
AP Antenna Height	m	20	15	10	50
STA Antenna Height	m	2	2	2	2
Okumura Hata (A+B*LOG(d)+C)					
A		142.91	55.16	55.16	55.16
B		36.38	53.28	56.45	37.50
C		1.95	10.60	9.60	8.20
RX Antenna Gain (AP)	dBi	12	12	12	12
Total Path Loss (L)	dB	125.84	129.91	132.74	134.73
Shadowing	dB	12.00	7.00	3.00	2.00
Path Loss + Shadowing	dB	137.84	136.91	135.74	136.73
Tx Power (STA)	dBm	13	13	13	13
Tx Antenna Gain (STA)	dBi	3	3	3	3
Received Signal Power(RSS)	dBm	-109.84	-108.91	-107.74	-108.73
NF+Implementation	dB	5	5	5	5
N <sub>total</sub>	dBm	-169.00	-169.00	-169.00	-169.00
BW	kHz	800	800	800	800
Total (N)	dBm	-110.0	-110.0	-110.0	-110.0
Assumed SNR (RSS/N)	dB	1.0	1.0	1.0	1.0
Superficial Link Margin (Includng Fading)	dB	-0.9	0.1	1.2	0.2
Substantial Link Margin RSS/Sensitivity(-114dBm)	dB	4.2	5.1	6.3	5.3

**LECIM-MR-PSK 500Kcps/1MHz (@ 2400MHz) Required Eb/No (Based on COST231 Hata Model & Erceg Model)****Large City****Hilly****Mid-Hilly/Flat****Flat**

Parameter	unit	Sensor to AP Large Urban	Sensor to AP Mid-city/Suburban	Sensor to AP Suburbanl	Sensor to AP Rural (Open Site)
Frequency	MHz	2400	2400	2400	2400
Distance	m	300	1600	1600	8000
AP Antenna Height	m	20	15	10	50
STA Antenna Height	m	2	2	2	2
Okumura Hata (A+B*LOG(d)+C)					
A		142.91	55.16	55.16	55.16
B		36.38	53.28	56.45	37.50
C		1.95	10.60	9.60	8.20
RX Antenna Gain (AP)	dBi	12	12	12	12
Total Path Loss (L)	dB	125.84	129.91	132.74	134.73
Shadowing	dB	12.00	7.00	3.00	2.00
Path Loss + Shadowing	dB	137.84	136.91	135.74	136.73
Tx Power (STA)	dBm	13	13	13	13
Tx Antenna Gain (STA)	dBi	3	3	3	3
Received Signal Power(RSS)	dBm	-109.84	-108.91	-107.74	-108.73
NF+Implementation	dB	5	5	5	5
No	dBm	-169.00	-169.00	-169.00	-169.00
BW	kHz	800	800	800	800
Total (N)	dBm	-110.0	-110.0	-110.0	-110.0
Data Rate	kbps	3.9	3.9	3.9	3.9
Eb	dBm	-145.75	-144.82	-143.65	-144.64
Fading Margin (only for E/No calculation)	dB	15.00	15.00	15.00	15.00
Eb/No	dB	8.25	9.18	10.35	9.36

# Conclusion

## Minimum extension on 15.4 fulfilling LECIM requirement

Both of proposed LECIM-MR-OFDM and DSSS-PSK are intended to be minimum extension of existing IEEE802.15.4 PHY including 15.4g draft to fulfill LECIM requirements with viable CapEx. & OpEx. by enhanced reliability, including possible resilient relaying with data rate adaptation.

LECIM extension of MR-OFDM is to append PUSC (Partial Usage of Sub-Carriers) function on existing MR-OFDM scheme in order to increase per-bit energy of transmission and diversity gain additionally. Also, MAC frequency agility mechanism (e.g. TSCH of IEEE802.15.4e) works with it as well.

LECIM extension of DSSS-PSK is to supplement existing MR-OQPSK with FEC in order to fill a few modulation schemes using medium chip rates (e.g. 300/500Kcps) with FEC and to fulfill LECIM requirements.

## Expecting PHY Overview including IEEE802.15.4k (except for UWB)

Std 15.	Modulation Scheme	Data Rates	Channel Spacing	FEC / Interleaver	Rx Sensitivity 10%/250octet (w/t FEC)	Remarks
4i	DS-OQPSK	100kbps	600kHz	No	-85dBm(1%20octet) w/o FEC	400kcps(25ksymbol/s)
4i	DS-OQPSK	250kbps	2MHz	No	-85dBm(1%20octet) w/o FEC	1Mcps(62.5ksymbol/s)
4i	DS-OQPSK	250kbps	5MHz	No	-85dBm(1%20octet) w/o FEC	2Mcps(62.5ksymbol/s)
4i	DS-BPSK	20k/40kbs	600k/2MHz	No	-92dBm(1%20octet) w/o FEC	300kcps/600kcps
4g	DS-OQPSK	31.25k/62.5/125/250/500kbps	2M/5MHz	PHR:60bit/PDU:126bit	-110/-105/-100/-95/-90dBm	1Mcps/2Mcps
4g	DS-OQPSK	6.25/12.5/25k/50kbps	200kHz	PHR:60bit/PDU:126bit	-110/-105/-100/-95/-90dBm	100kcps
4k	DS-PSK	4.6875/9.375/18.75/37.5/kbps	600/800kHz	TBD PHR:60/PDU:126	-111/-108/-105/-100dBm	EU868M/JP920M, etc.
4k	DS-PSK	3.906/7.8125/15.625/31.25kbps	1MHz	TBD PHR:60/PDU:126	-111/-108/-105/-100dBm	Asia Region inc.JP920
4f	MSK	31.25k/250kbps	60k/580kHz	No		
4i	GFSK	100kbps	400kHz	No	-85dBm(1%20octet) w/o FEC	for 4d Japan sub-1G
4g	Filter FSK	4.8/9.6kbps	12.5kHz	Option/16symbols	-97dBm+10log(R/50kbps)	for US450-470MHz
4g	Filter FSK	10/20/40kbps	12.5kHz	Option/16symbols	-97dBm+10log(R/50kbps)	for US928-960MHz
4g	Filter FSK	100kbps/150kbps/200kbps	400kHz	Option/16symbols	-97dBm+10log(R/50kbps)	
4g	Filter FSK	400kbps	600kHz	Option/16symbols	-97dBm+10log(R/50kbps)	
4g	OFDM	50/100/150/200/300kbps	200kHz	1symbol/xSF(upto192bit)	-105/-103/-100/-97/-94dBm	16DFT(14tones)
4g	OFDM	50/100/200/300/400/600kbps	400kHz	1symbol/xSF(upto192bit)	-105/-103/-100/-97/-94/-91dBm	32DFT(26tones)
4g/k	OFDM	6.25/12.5/25/50/100/200/400/600/800kbps	800kHz	1symbol/xSF(upto192bit)	-114/-111/-108/-105/-103/-100/-97/-94/-91dBm	64DFT(52tones)
4g/k	OFDM	12.5/25/50/100/200/400/800kbps	1.2MHz	1symbol/xSF(upto192bit)	-112/-109/-106/-103/-100/-97/-94dBm	128DFT(104tones)

**End**

**Open to discuss for mergers and simplifications !!**