

Project: IEEE P802.15 Working Group for Wireless Personal Area Networks (WPANs)

Submission Title: Texas Instruments Impulse Radio UWB Physical Layer Proposal

Date Submitted: 04 May, 2009

Source: June Chul Roh, Anuj Batra, Sudipto Chakraborty, Srinath Hosur, and Timothy Schmidl
Texas Instruments
12500 TI Blvd MS 8649, Dallas, TX, USA
E-mail: {jroh, batra, schakraborty, hosur, schmidl}@ti.com

Re: Response to IEEE 802.15.6 call for proposals

Abstract: This document describes the Texas Instruments impulse radio UWB physical layer proposal for IEEE 802.15.6.

Purpose: For discussion by IEEE 802.15 TG6

Notice: This document has been prepared to assist the IEEE P802.15. It is offered as a basis for discussion and is not binding on the contributing individual(s) or organization(s). The material in this document is subject to change in form and content after further study. The contributor(s) reserve(s) the right to add, amend or withdraw material contained herein.

Release: The contributor acknowledges and accepts that this contribution becomes the property of IEEE and may be made publicly available by P802.15.

Texas Instruments Impulse Radio UWB Physical Layer Proposal

June Chul Roh, Anuj Batra, Sudipto Chakraborty,
Srinath Hosur, and Timothy Schmidl

Texas Instruments

May 2009

Outline

- Motivation
- Details About the Impulse Radio UWB PHY:
 - Frequency Band of Operation
 - Frame Format: Preamble, Header, PSDU
 - Symbol Structure
 - Burst Position Modulation with Time-Hopping (BPM-TH)
 - Time-Hopping Sequence
 - FEC: BCH Codes
 - System Parameters
- Performance Results:
 - Link Budget and Receiver Sensitivity
 - Simulation Results in AWGN and Multipath Channels
 - Performance with Co-channel Interference
 - Complexity and Power Consumption
- Summary and Conclusions

Overview of Proposal

- Goal: Design a low-power, low-complexity UWB PHY for BAN
- Start by re-using some aspects of IEEE 802.15.4a PHY:
 - Preamble structure
 - Burst position modulation and time-hopping (BPM-TH)
- Add new features that reduce complexity and lower power consumption:
 - More efficient symbol structure – eliminates unnecessary overheads
 - A new time-hopping sequence that supports new symbol structure
 - Limit modulation scheme to BPM-TH – simplifies receiver
 - Limit systems to a single bandwidth of 512 MHz – simplifies receiver
 - Limit systems to higher frequency bands – eliminates need for complex DAA
 - Replace RS codes with low-complexity binary BCH codes
 - Add support for simultaneous operation of at least 12 piconets

Key Improvements over 15.4a

- New frequency band plan
 - Use only the UWB high band → does not require power-hungry DAA
 - Each band has 512 MHz bandwidth
- New symbol structure and time-hopping sequence
 - No fixed guard interval for improved PHY efficiency
 - Time-hopping sequence is designed to prevent inter-symbol interference (ISI)
- Binary burst position modulation with time-hopping (BPM-TH)
 - Binary BPM → simple non-coherent receiver in mind
 - BPSK and convolutional coding of 802.15.4a is not included in this proposal → want ultra-simple receivers
- Low-complexity binary FEC codes
 - BCH (31, 16, $t = 3$), BCH (63, 51, $t = 2$), BCH (63, 57, $t = 1$)

WW Regulations on UWB Band

- Low Band*

- DAA or LDC is a must (except USA) after 2010
- ⇒ DAA results in huge penalty on complexity and power for BAN transceivers

	PSD	Frequency Bands	Remarks
Australia	N/A	N/A	N/A
EU	-41.3 dBm/MHz	3.1 - 4.8 GHz	LDC or DAA is needed
		4.2 - 4.8 GHz	By Dec. 31, 2010
Japan	-41.3 dBm/MHz	3.4 - 4.8 GHz	DAA is needed
		4.2 - 4.8 GHz	By Dec. 31, 2010
Korea	-41.3 dBm/MHz	3.1 - 4.8 GHz	LDC or DAA is needed
		4.2 - 4.8 GHz	By Dec. 31, 2010
USA	-41.3 dBm/MHz	3.1 -10.6 GHz	

- High Band*

- DAA is not required
- ⇒ Ideal for low-complexity, low-power BAN
- Concern: only 1.25GHz bandwidth is common worldwide
- ⇒ Solution: new proposed band plan

	Frequency Bands	PSD	Remarks
Australia	N/A	N/A	N/A
EU	6 - 8.5 GHz	-41.3 dBm/MHz	
Japan	7.25 - 10.25 GHz	-41.3 dBm/MHz	
Korea	7.2 -10.2 GHz	-41.3 dBm/MHz	
USA	3.1 -10.6 GHz	-41.3 dBm/MHz	
Common	7.25 -8.5 GHz	-41.3 dBm/MHz	

* Tables from P802.15-08-0034

Frequency Bands of Operation

- Channelization:

Band Number	Supported Region	BW (MHz)	Low Freq. (MHz)	Center Freq. (MHz)	High Freq. (MHz)
1	US, EU	512	6400	6656	6912
2	US, EU	512	6912	7168	7424
3	US, EU, Japan, Korea	512	7424	7680	7936
4	US, EU, Japan, Korea	512	7936	8192	8448
5	US, Japan, Korea	512	8448	8704	8960

- All bands are located in UWB high band
- At least 3 bands available per country: 4 SOPs per band → support at least 12 SOPs
- Center frequencies are integer multiples of 512 MHz: $512 \times [13, 14, 15, 16, 17]$
- PLL is easier to implement than PLL for 802.15.4a

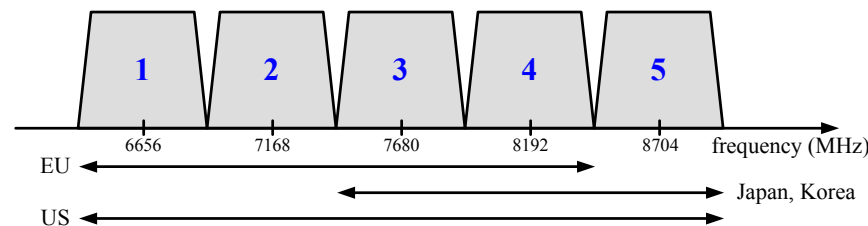

PLCP Frame Format

- PPDU comprised of three components:
 - PLCP Preamble: used for packet detection, timing acquisition, carrier frequency offset estimation, etc
 - PLCP Header: convey information about how to decode PSDU
 - PSDU: MAC Header + MAC Frame Body (information) + FCS

- Structure:

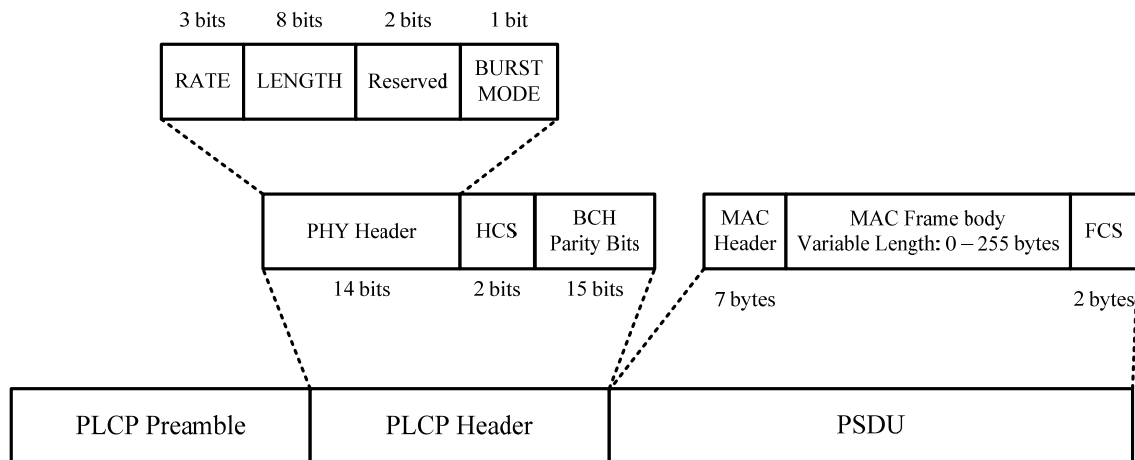

PLCP Preamble

- Reuse the 802.15.4a preamble signal structure: $N_{sync} = 64$ or 16 ; $N_{sfd} = 8$
- Use the length 31 ternary codes (of 802.15.4a) with following band assignment
 - Define 4 preamble codes per band
 - Assign different preambles to adjacent bands, minimizes false alarms due to adjacent channel energy leaking into the desired band

Code index	Code sequence	Band number
1	-0000+0-0+++0+-000+--+++00--+0-00	1, 3, 5
2	0+0+-0+0+000-++0-+---00+00++000	1, 3, 5
3	--0+++000-+--+00++0+00-0000-0+0-	1, 3, 5
4	0000+-00-00-++++0+-+000+0-0++0-	1, 3, 5
5	-0+-00+++--+000-+0+++0-0+0000-00	2, 4
6	++00+00----+0+-000+0+0-+0+0000	2, 4
7	+0000+-0+0+00+000+0+-+---0-+00-+	2, 4
8	0+00-0-0++0000--+00-+0+-+0+00	2, 4

PLCP Header

- Proposed PLCP Header Structure (31 bits)

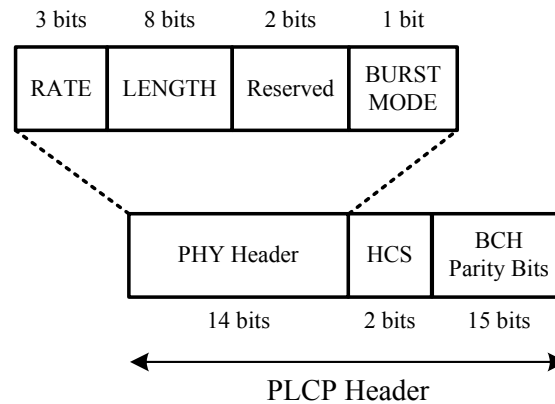

- Format the PHY header as shown in figure based on data provided by the MAC
 - Calculate the 2-bit HCS value over the PHY header
 - CRC-2 polynomial: $g(x) = 1 + x + x^2$
 - Apply a BCH (31,16) code to PHY header + HCS
- The resulting encoded bits are modulated using the lowest data rate

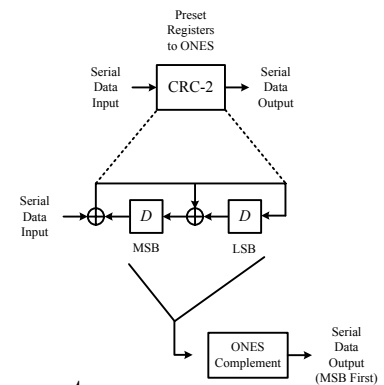

Burst Position Modulation with Time-Hopping

- Basic concept:
 - Binary PPM based modulation
 - Multiple pulses are continuously transmitted in a symbol
 - Time-hopping for multiple access (symbol-rate hopping)
 - Random pulse polarity changes within a pulse burst
- Signal for k -th symbol interval may be mathematically expressed*:

$$x^{(k)}(t) = \sum_{n=0}^{N_{cpb}-1} s_{kN_{cpb}+n} p(t - d^{(k)}T_{BPM} - h^{(k)}T_{burst} - nT_c)$$

$p(t)$: transmitted pulse shape at the antenna input,

$s_{kN_{cpb}+n} \in \{-1, 1\}$: chip scrambling code used during the k -th symbol interval,

$d^{(k)} \in \{0, 1\}$: k -th data symbol carrying information,

$h^{(k)} \in \{0, 1, \dots, N_{hop} - 1\}$: time-hopping position for the burst during the k -th symbol interval,

N_{cpb} : number of chips per burst,

$T_{burst} = N_{cpb}T_c$: slot time (or burst time),

T_c : chip time,

$T_{BPM} = N_{hop}T_{burst}$: BPM (burst position modulation) interval.

* For proposed symbol structure (slide 15).

802.15.4a Symbol Structure

- 802.15.4a symbol structure: designed for much longer range (0–30 m)

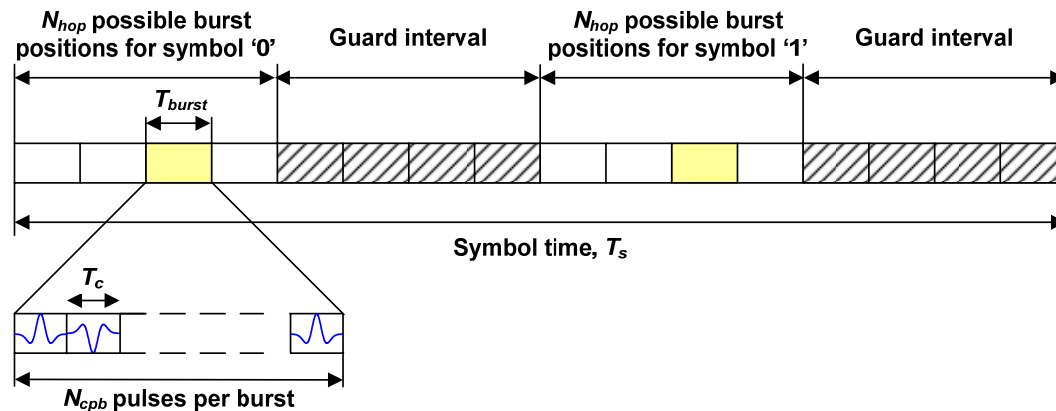

- 50% of symbol duration is reserved as guard interval (GI): 50% of symbol is *overhead!*
- GI is unnecessarily large compared to typical channel delay spread for data rates of interest
- Why two guard intervals in 15.4a?
 - 1st GI avoids interference from symbol '0' to symbol '1' region
 - 2nd GI prevents inter-symbol interference (ISI)

Elimination of 1st Guard Interval

- 1st guard interval (GI) of 15.4a is unnecessary as BPM-TH inherently provides GI
 - Since $(N_{hop}-1)T_{burst} > \tau_{max}$ for data rates of interest (τ_{max} : max expected delay spread of channel)
- ‘Fixed-length’ 2nd GI with $T_{GI} > \tau_{max}$ can be used to prevent ISI

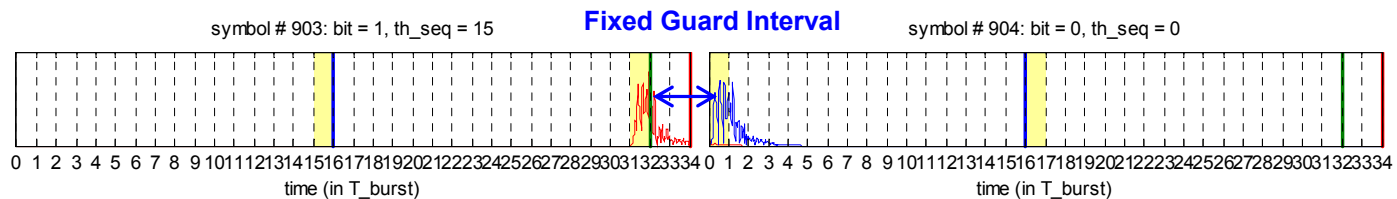

- Leads to a more efficient symbol structure with less overhead

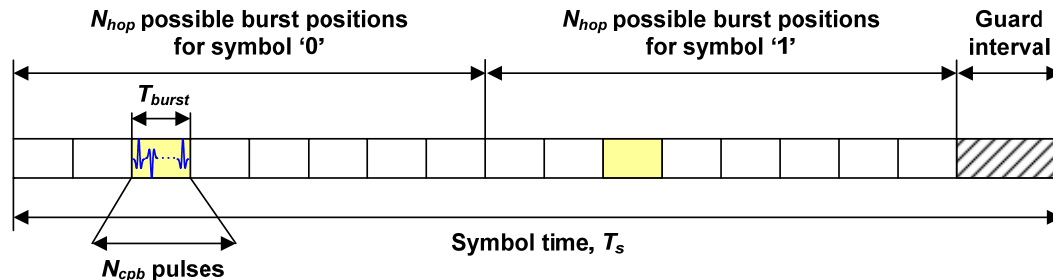

- Q: Can we do better?

Proposed Optimal Symbol Structure (1)

- A: Yes, We Can!
- ISI occurs when transmitting a ‘1’ on previous symbol at the end of the symbol, and when transmitting a ‘0’ on current symbol in the beginning of the symbol

• Example:

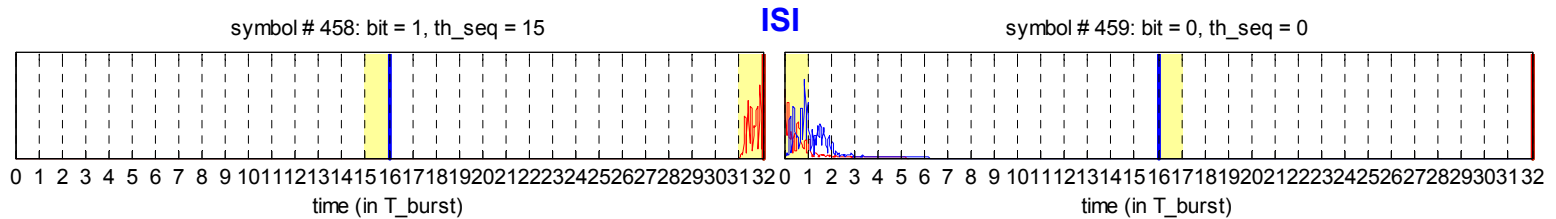

• Can eliminate these cases from happening by designing the time-hopping sequence properly!

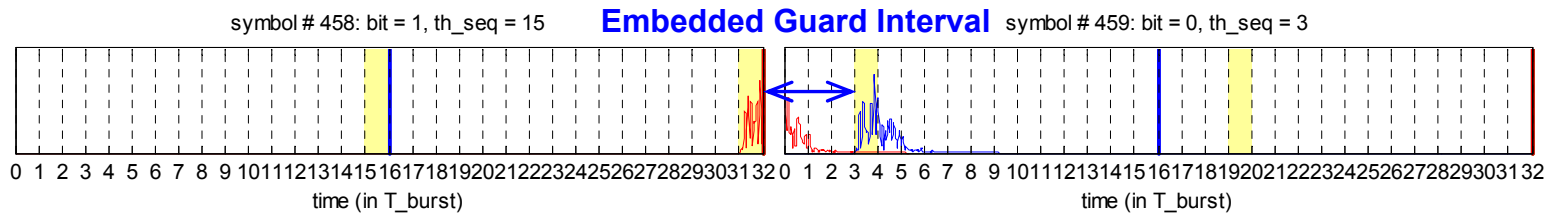

Proposed Optimal Symbol Structure (2)

- New proposed symbol structure: highly optimized for BAN channel environments

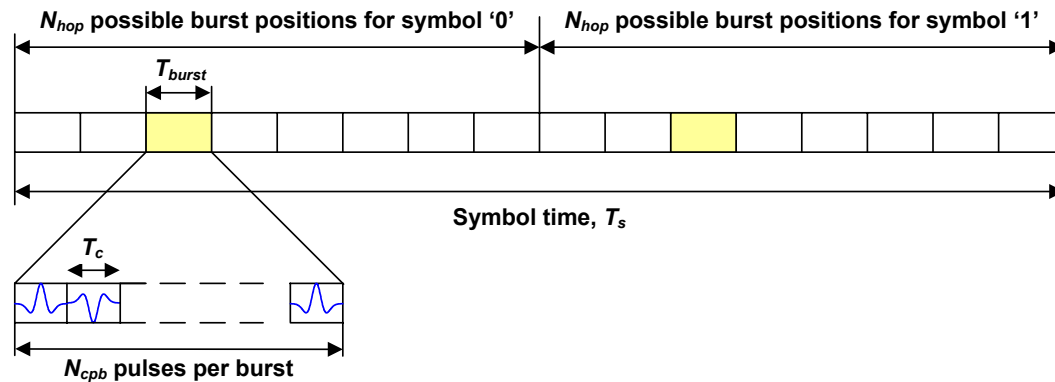

- Completely eliminate the two fixed guard intervals of 15.4a
- Time-hopping sequence provides embedded guard interval *only when necessary*
 - ISI can happen when two consecutive hop locations are at the end and in the beginning of symbol
 - Design time-hopping to avoid the ISI condition
- Increased channel efficiency can be used for
 - Increasing the overall possible data rates (increase channel efficiency), and/or
 - Providing better interference mitigation capability by increasing N_{hop}

Time-Hopping Sequence

- Time-hopping sequence design constraint to avoid ISI:

$$h^{(k)} \geq h^{(k-1)} - (N_{hop} - N_{ch} - 1) \quad \text{for } k \geq 1 \tag{1}$$

$h^{(k)} \in \{0, 1, \dots, N_{hop} - 1\}$: time-hopping sequence for the k -th symbol,

τ_{max} : expected maximum delay spread of channel,

$N_{ch} = \left\lceil \frac{\tau_{max}}{T_{burst}} \right\rceil - 1$: embedded guard interval length (in T_{burst})

- An intuitive example:
 - Let $N_{hop} = 8$ and $N_{ch} = 4$

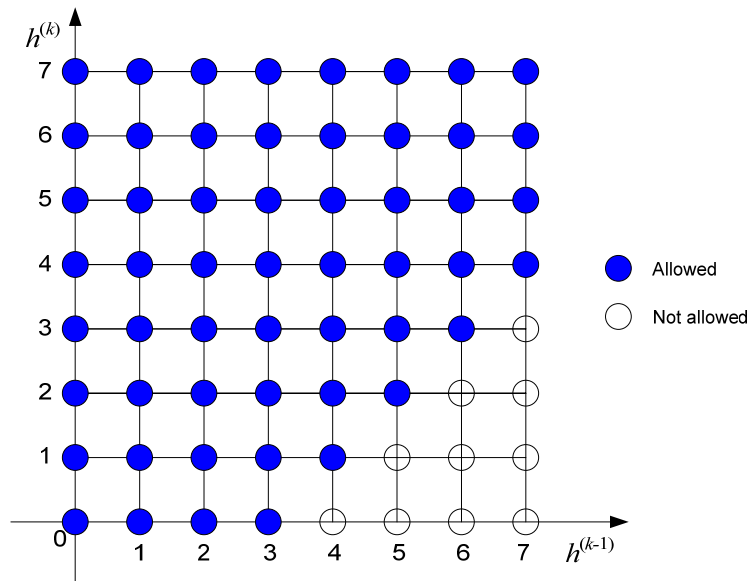

Time-Hopping Sequence Generation

1. Generate a random number $z^{(k)} \in \{0, 1, \dots, N_{hop} - 1\}$ by tapping $m = \log_2(N_{hop})$ shift registers of the 802.15.4a LFSR. For each symbol interval, the LFSR shall be clocked N_{cpb} times.

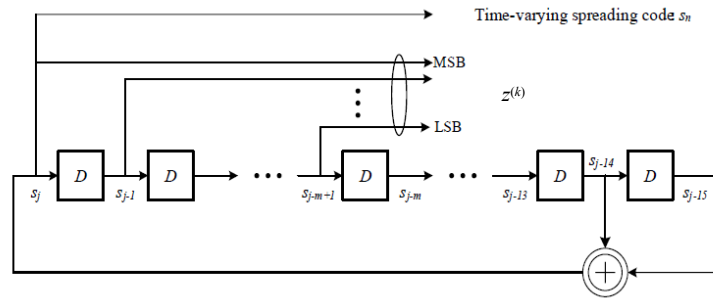

2. Calculate related parameters: $\alpha = h^{(k-1)} - \gamma$, $N_{reduced} = N_{hop} - \alpha$ (or use a look-up table)

where $\gamma = N_{hop} - N_{ch} - 1$ is known (pre-calculated) for each data rate.

3. Generate time-hopping sequence as follows:

$$h^{(k)} = \begin{cases} z^{(k)}, & \text{if } h^{(k-1)} \leq \gamma \\ [(z^{(k)} + c^{(k)}) \bmod N_{reduced}] + \alpha, & \text{if } h^{(k-1)} > \gamma \end{cases}$$

where $c^{(k)}$ is a 7-bit counter when $N_{hop} = 16$, or a 6-bit counter when $N_{hop} = 8$.

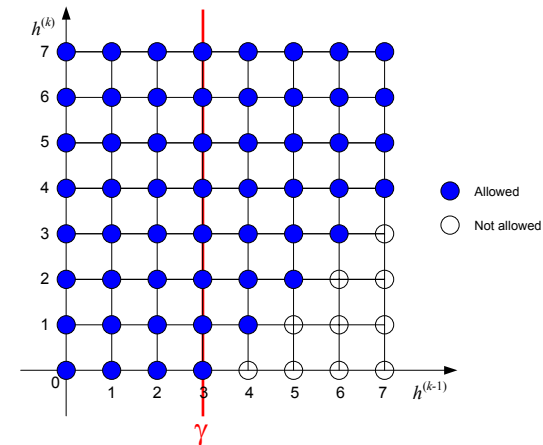

BCH Encoder

- BCH (31,16) code: $g(x) = 1 + x + x^2 + x^3 + x^5 + x^7 + x^8 + x^9 + x^{10} + x^{11} + x^{15}$
- Low-complexity, low-power implementation:

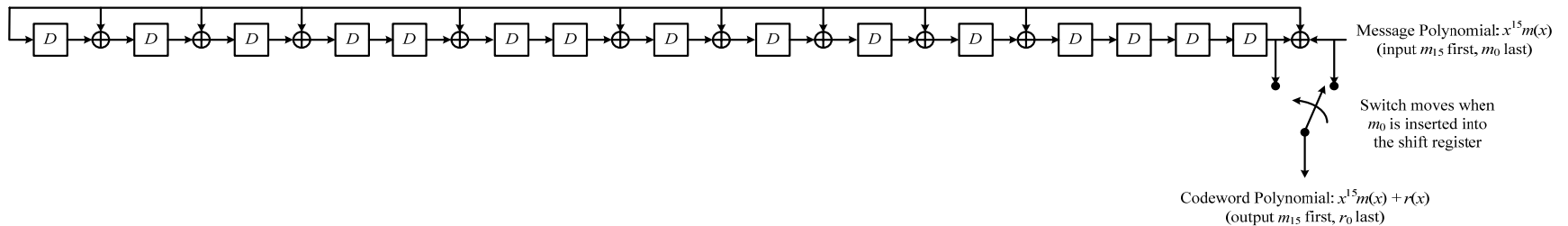

- BCH (63, 51): $g(x) = 1 + x^3 + x^4 + x^5 + x^8 + x^{10} + x^{12}$
- BCH (63, 57): $g(x) = 1 + x + x^6$

Process for BCH Encoding

1. Compute the number of bits in the PSDU: $N_{PSDU} = (N_{MACheader} + N_{payload} + N_{FCS}) \times 8$
2. Calculate the number of BCH codewords: $N_{CW} = \left\lceil \frac{N_{PSDU}}{k} \right\rceil$
3. Compute the total number of shortening bits*: $N_{shorten} = N_{CW} \times k - N_{PSDU}$
4. Calculate the number of shortening bits needed per codeword: $N_{spcw} = \left\lfloor \frac{N_{shorten}}{N_{CW}} \right\rfloor$
5. Distribute shortening bits uniformly over codewords:
 - a. Each of the first $rem(N_{shorten}, N_{CW})$ codewords have $N_{spcw} + 1$ shortened bits
 - b. Remaining codewords have N_{spcw} shortened bits
6. Shortened bits are *not* transmitted on-air, but receiver *will* re-insert them into known locations

* Shortened bits are message bits that are set to zero

System Parameters

MCS number	1	2	3	4	5	6	7
Chip rate (MHz)	512	512	512	512	512	512	512
Chip time (ns), T_c	1.953125	1.953125	1.953125	1.953125	1.953125	1.953125	1.953125
Modulation	BPM-TH	BPM-TH	BPM-TH	BPM-TH	BPM-TH	BPM-TH	BPM-TH
BCH code rate, r	16/31	16/31	16/31	16/31	51/63	57/63	57/63
# bursts in symbol, N_{burst}	32	32	32	32	32	16	16
# hop bursts, N_{hop}	16	16	16	16	16	8	8
# of chips in burst, N_{cpb}	64	32	16	8	6	5	3
# chips per symbol, N_{cps}	2048	1024	512	256	192	80	48
Burst length (ns), T_{burst}	125.0000	62.5000	31.2500	15.6250	11.7188	9.7656	5.8594
Symbol period (ns), T_s	4000.00	2000.00	1000.00	500.00	375.00	156.25	93.75
Symbol rate (ksps), R_s	250.00	500.00	1000.00	2000.00	2666.67	6400.00	10666.67
Data rate (kbps), R_b	129.03	258.06	516.13	1032.26	2158.73	5790.48	9650.79
Average PRF (MHz)	16.00	16.00	16.00	16.00	16.00	32.00	32.00
N_{ch} for TH sequence	1	1	2	3	4	4	5

Energy-Detection Based Non-coherent Receiver

- Low complexity and low power-consumption receiver

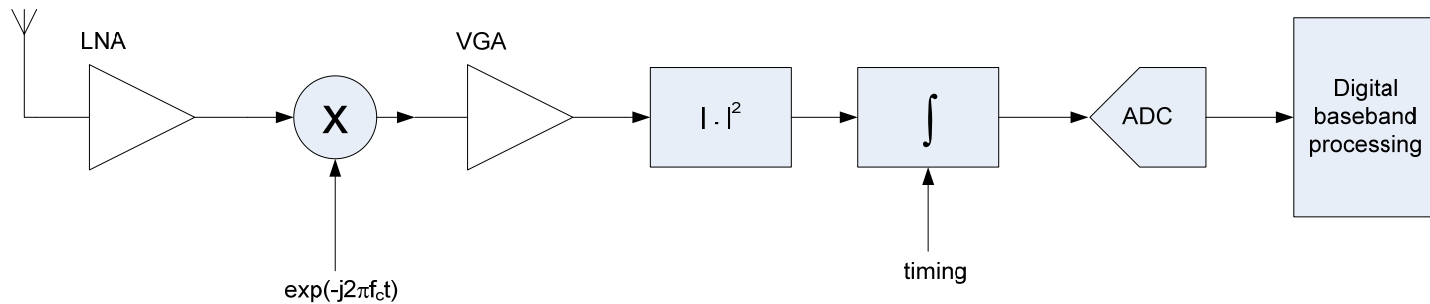

- Other non-coherent receiver structures are also possible

Link Budget and Receiver Sensitivity

Parameter	Value	Value	Value	Unit
Bit rate (R_b)	129.03	1032.26	9650.79	kbps
Center frequency (f_c)	8704	8704	8704	MHz
Bandwidth (B)	512	512	512	MHz
Average Tx power	-16.21	-16.21	-16.21	dBm
Tx/Rx switch loss	1	1	1	dB
Average Tx power before Tx Ant (P_T)	-17.21	-17.21	-17.21	dBm
Tx antenna gain (G_T)	0	0	0	dBi
Distance (d)	3	3	2	m
Path loss at d meter (L)	60.77	60.77	57.25	dB
Rx antenna gain (G_R)	0	0	0	dBi
Rx power ($P_R = P_T + G_T + G_R - L$)	-77.98	-77.98	-74.46	dBm
Average noise power per bit ($N = -174 + 10 \cdot \log_{10} R_b$)	-122.89	-113.86	-104.15	dBm
Rx noise figure (N_F)	10	10	10	dB
Total noise power per bit ($P_N = N + N_F$)	-112.89	-103.86	-94.15	dBm
Received SNR	34.91	25.88	19.69	dB
Minimum required E_b/N_0 (S)	17.82	14.49	13.03	dB
Implementation loss (I)	3	3	3	dB
Link margin ($M = P_R - P_N - S - I$)	14.09	8.39	3.67	dB
Proposed min Rx sensitivity level	-92.07	-86.37	-78.13	dBm

Justification for IEEE 802.15.3a Channel Model (1)

- 802.15.6 CM3: Average Power Decay Profile

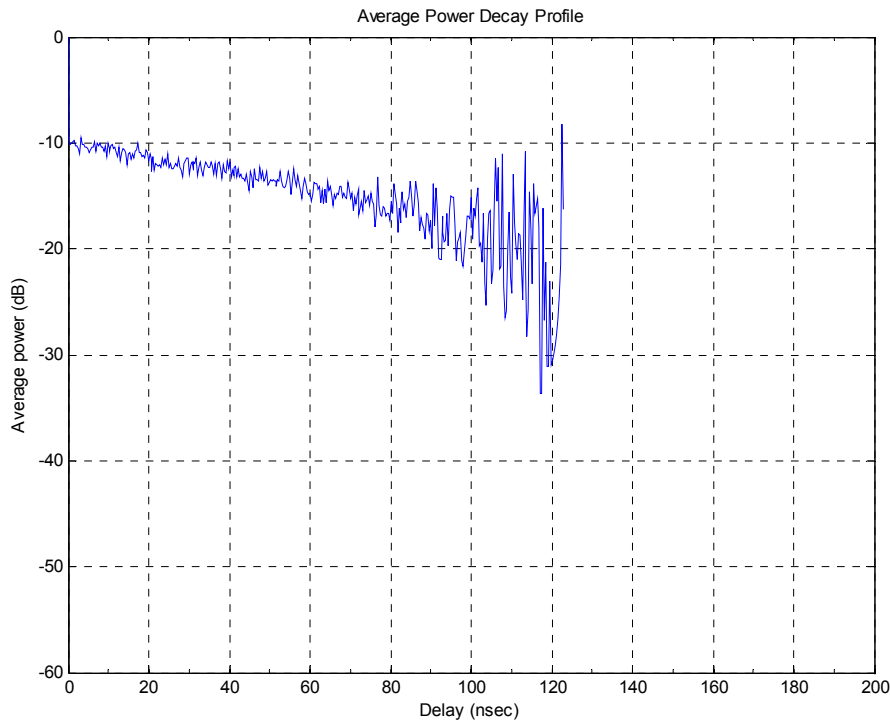

- PDP decays 30dB at $\tau = 200$ ns
- Mean excess delay: 26.3 ns
- RMS delay spread: 19 ns

- 802.15.6 CM4: Average Power Decay Profile

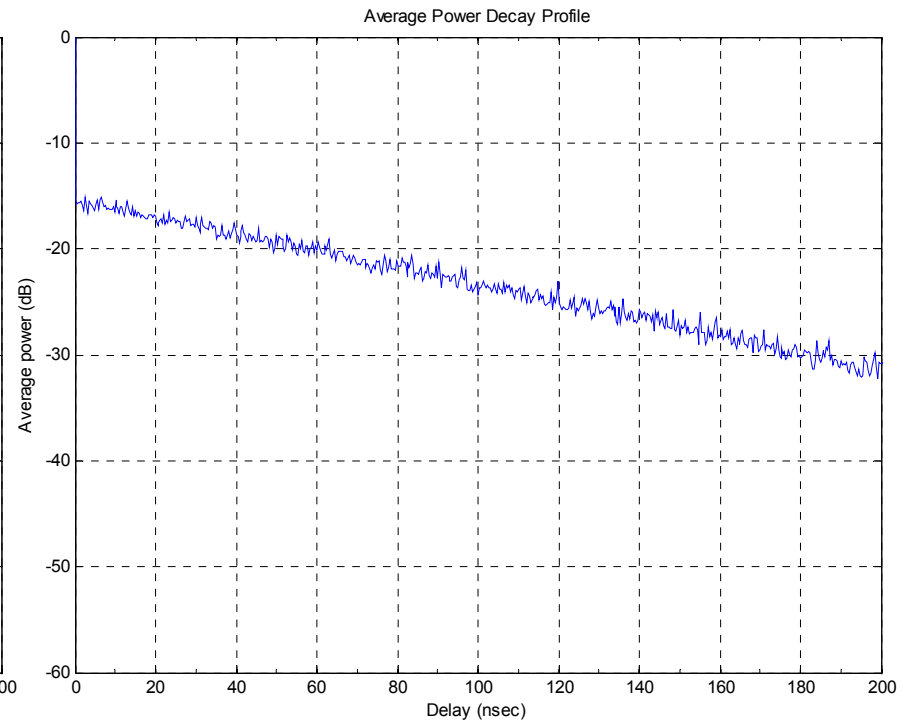

- PDP decays 30dB at $\tau = 180$ ns
- Mean excess delay: 40.9 ns
- RMS delay spread: 42 ns

Justification for IEEE 802.15.3a Channel Model (2)

- 802.15.4a CM3 (Indoor office, 3–28m, LOS)

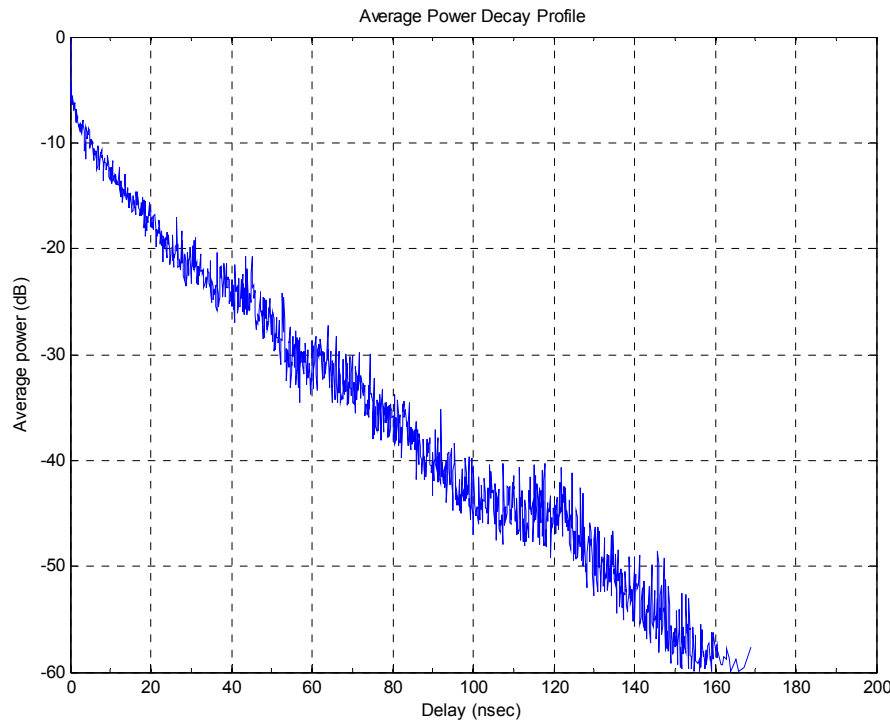

- PDP decays 30dB at $\tau = 60$ ns
- Mean excess delay: 9.1 ns
- RMS delay spread: 10 ns

- 802.15.4a CM4 (Indoor office, 3–28m, NLOS)

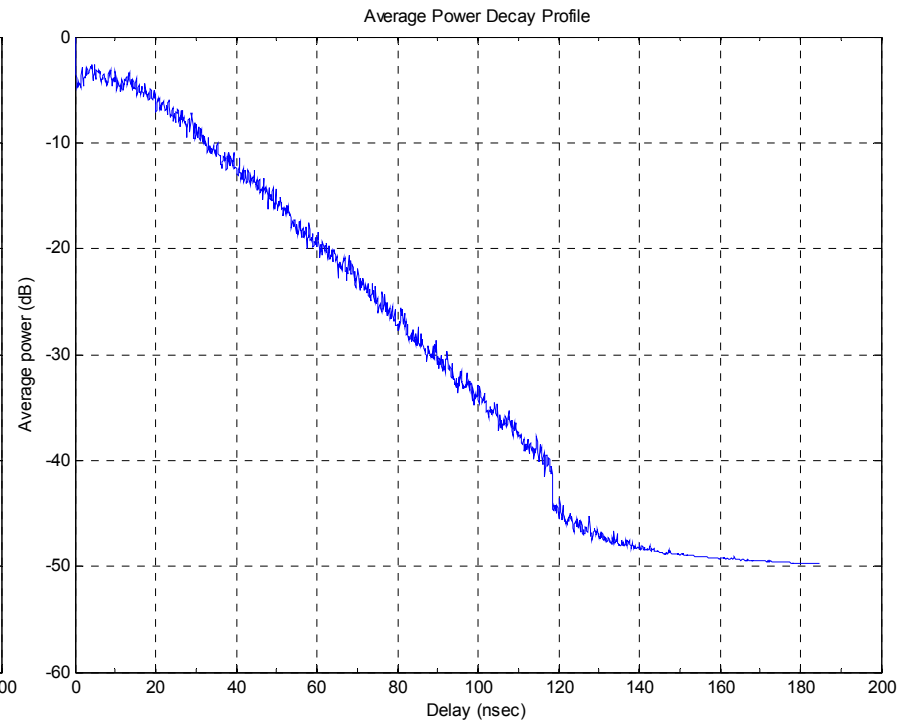

- PDP decays 30dB at $\tau = 90$ ns
- Mean excess delay: 16.5 ns
- RMS delay spread: 13 ns

Justification for IEEE 802.15.3a Channel Model (3)

- 802.15.3a CM1 (0–4m, LOS): Average PDP

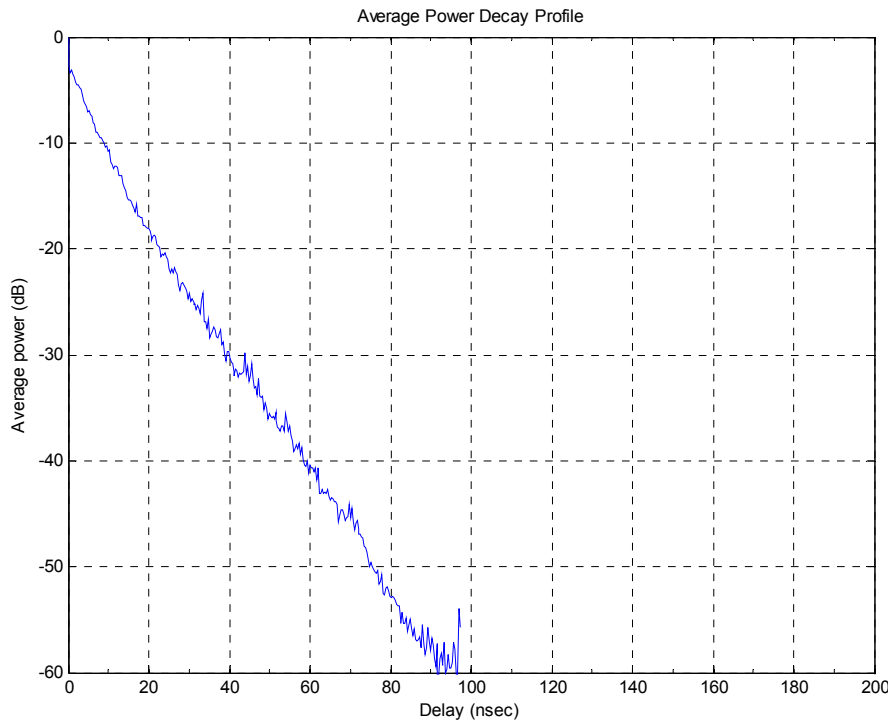

- PDP decays 30dB at $\tau = 40$ ns
- Mean excess delay: 5.2 ns
- RMS delay spread: 6 ns

- 802.15.3a CM2 (0–4m, NLOS): Average PDP

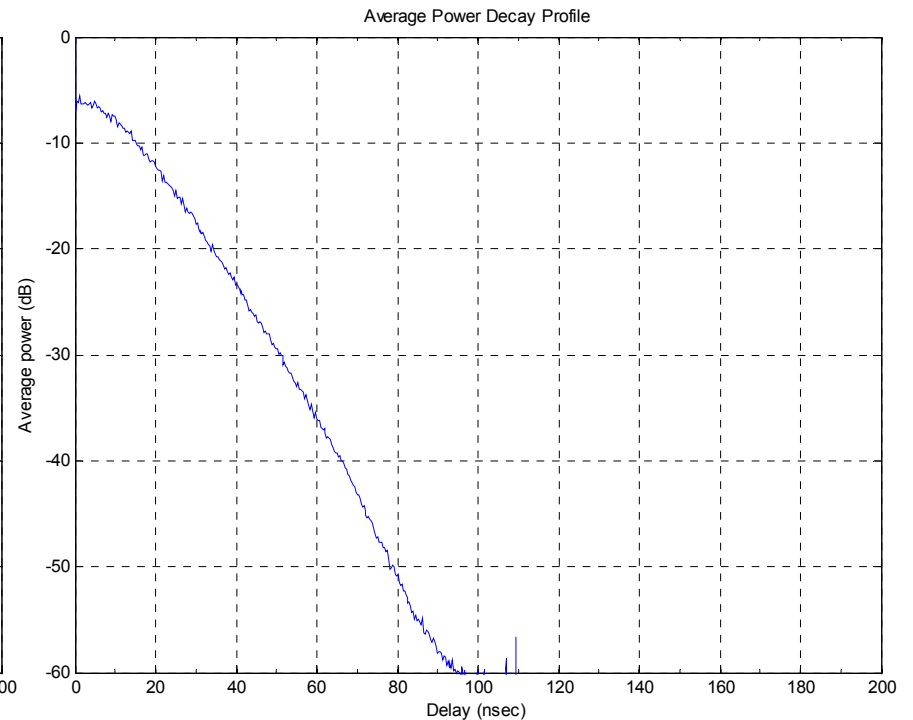

- PDP decays 30dB at $\tau = 50$ ns
- Mean excess delay: 9.6 ns
- RMS delay spread: 8 ns

Simulation Parameters

- PSDU = 256 bytes
- Transmit pulse: root-raised cosine pulse ($f_{cutoff} = 240$ MHz and $\alpha = 0.6$)
- Channel
 - AWGN
 - Multipath channel: 802.15.3a CM1 and CM2 (0–4m, LOS, NLOS)
 - PER results in multipath channel are averaged over 95% best channels
- Receiver
 - Energy-detection based non-coherent demodulator
 - Assume perfect packet detection and header decoding
 - Ideal timing, zero carrier-frequency offset

Packet Error Performance in AWGN

- AWGN results:

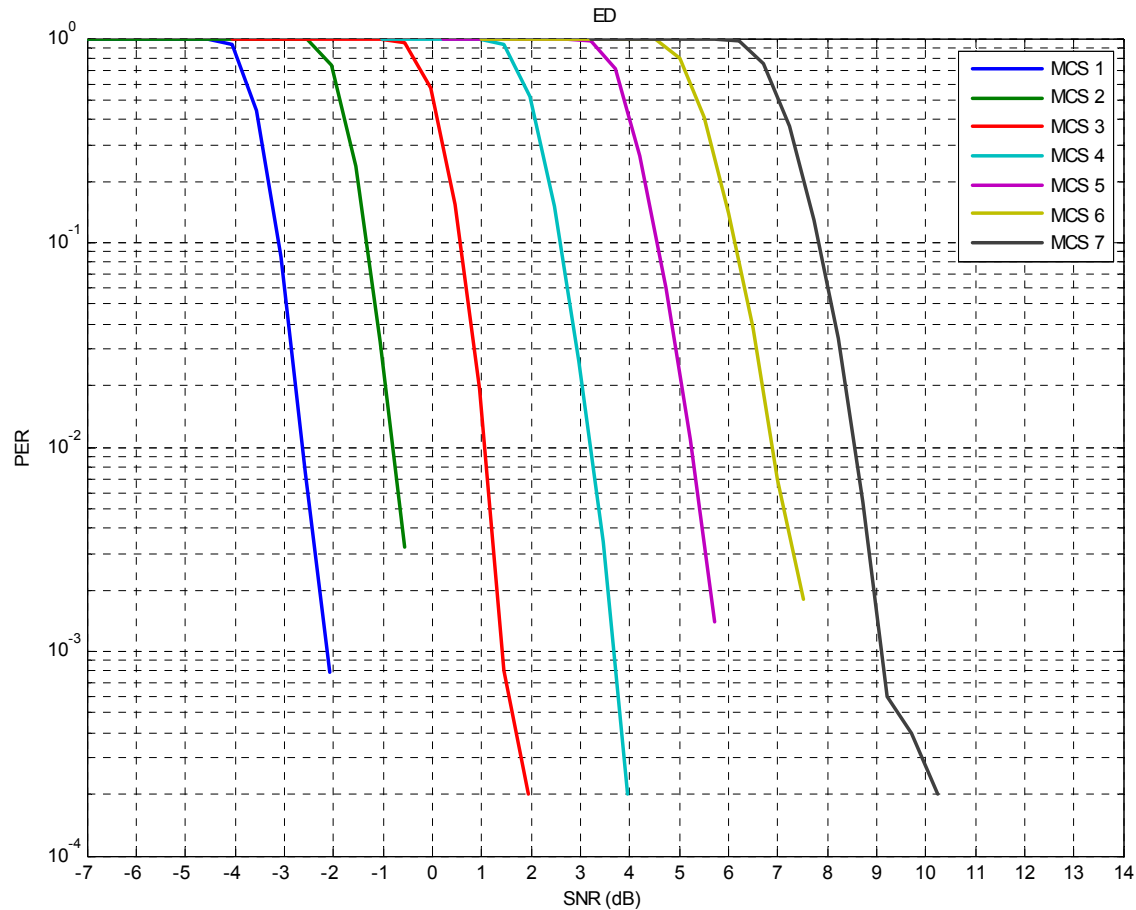

Packet Error Performance in Multi-path

- CM1

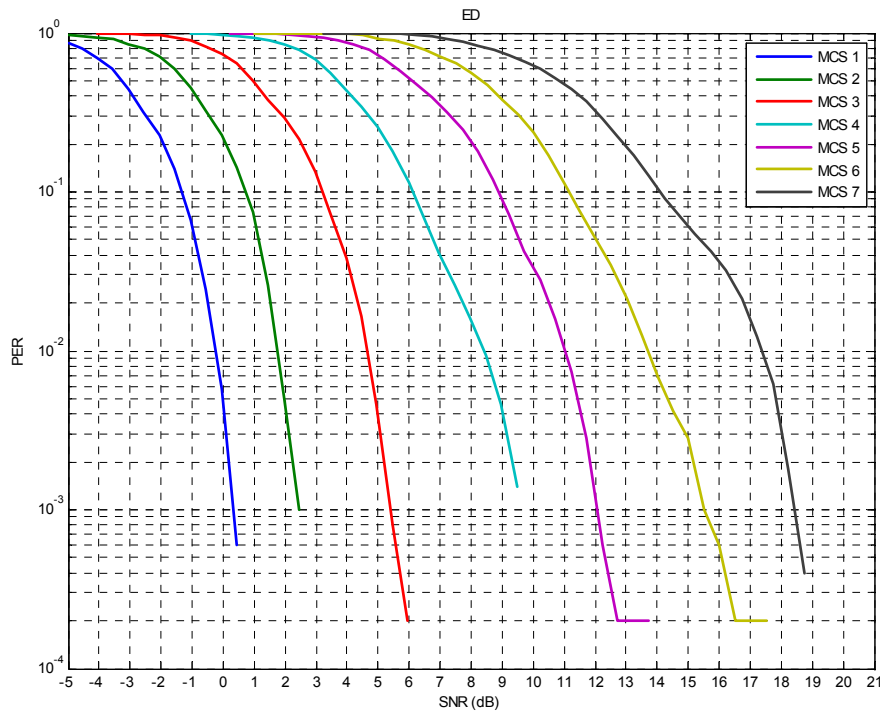

- CM2

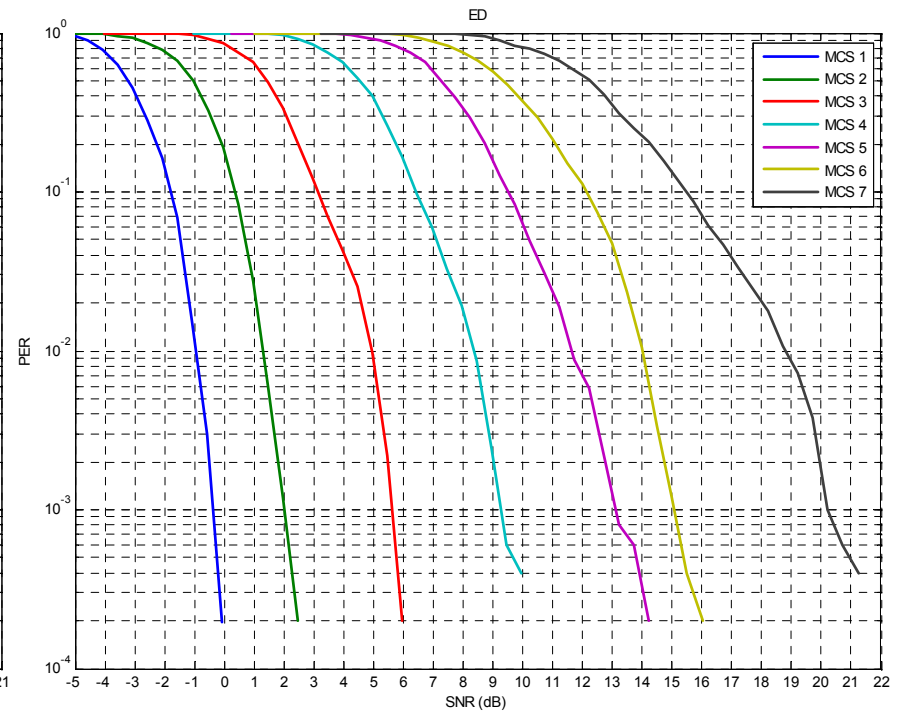

Performance in SOP Co-channel Interference (1)

- 4 SOPs in a band \rightarrow 3 interfering piconets
 - Interferers d_{Intf} from reference receiver
 - Interferers continuously transmitting
 - Asynchronous between signals from multiple piconets
 - Each piconet uses a unique time-hopping sequence
 - All devices transmit at 1Mbps
- Path loss model:
 - Free-space path loss model ($\exp \alpha = 2$)
 - $SIR = 10 \log_{10}(d_{Intf}/d_{Ref})^\alpha$ [dB] for a single interferer
- Channel:
 - Each signal passes through an independent multipath channel (15.3a CM1)
- Receiver: non-coherent receiver based on energy-detection

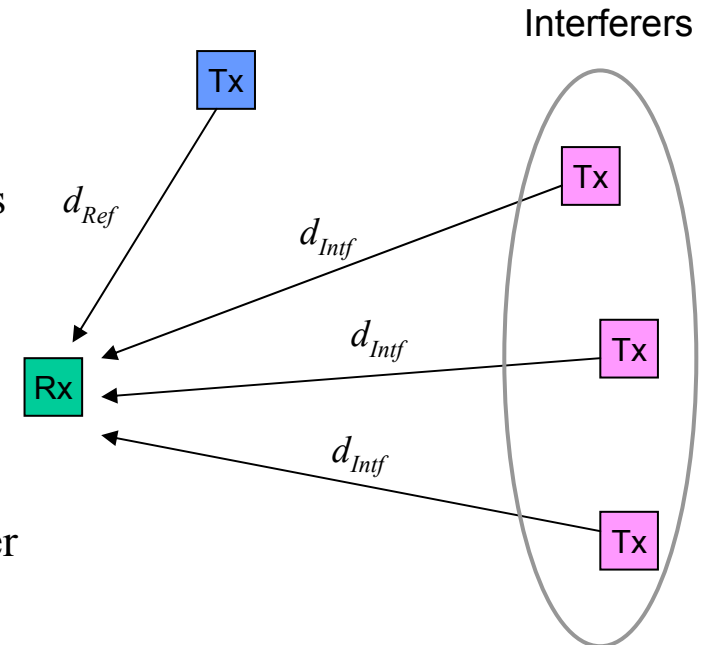

Performance in SOP Co-channel Interference (2)

- SOP results:

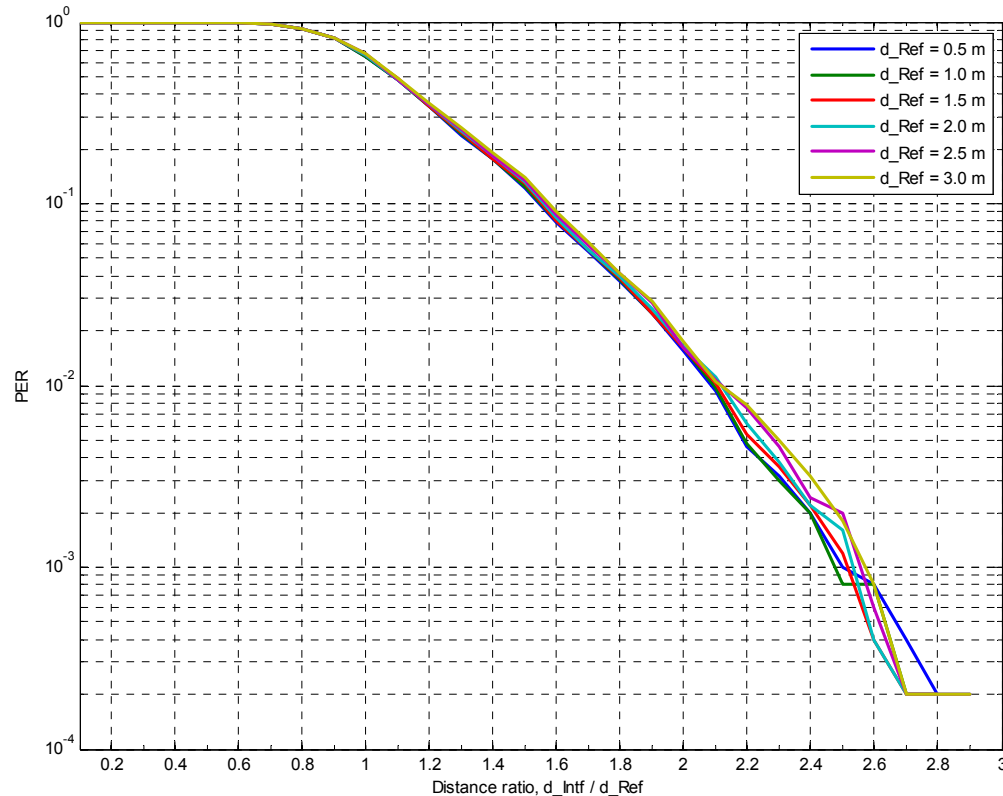

- Results: $d_{Intf} / d_{Ref} = 1.55$ (to maintain a PER = 10%)

Power Consumption

Data rate	1032.26 kbps	9650.79 kbps
Analog Tx		
Peak power	40 mW	27 mW
Idle power	0.2 mW	0.2 mW
Average power	1.6 mW	2.7 mW
Analog Rx		
Peak power	18 mW	18 mW
Idle power	0.2 mW	0.2 mW
Average power	2.0 mW	4.0 mW
Tx Total	2.1 mW	3.2 mW
Rx Total	2.5 mW	4.5 mW

* Power analysis is based on low-voltage, low-leakage 130 nm CMOS technology.

Comparison Criteria

Criteria	Proposed Capability
1. Regulatory	Compliant with TG6 regulatory document in UWB frequency band
2. Raw PHY data rate	129 kbps to 9.65 Mbps supported between node and hub
3. Transmission distance	PER and link budget shown to support 10% PER for 256 octet PSDU at 3 meters within all operating frequency bands proposed.
4. Packet error rate	
5. Link budget	
6. Power emission level	-17.21 dBm maximum EIRP which is under the regulated transmit power limit
7. Interference and coexistence	Channelization: 5 channels total, at least 3 frequency bands available in each region 4 SOP supported per band, at least 12 SOP piconets supported in each region Time-hopping and pulse polarization scrambling used to mitigate interference
8. Security	Can be combined with any MAC providing security
9. Reliability	Sufficient link margin in UWB multipath channel model
10. Quality of Service	Support high-level of QoS up to 9.65 Mbps
11. Scalability	Scalable data rate from common symbol rates
12. MAC transparency	Proposed PHY is transparent to MAC
13. Power Efficiency	Proposed PHY is optimized for low-complexity and low power consumption BAN transceivers
14. Topology	Star topology, broadcast beacon supported. Maximum number of nodes supported via multiple access mechanisms
15. Bonus Point	-

Summary and Conclusions

- Reuse the strengths of 802.15.4a PHY as much as possible
- Proposed a new frequency band plan → simplifies receiver, no DAA requirements
- New symbol structure, time-hopping sequence → eliminates ISI w/o needing a GI
- Low complexity and low power-consumption standard
 - Binary burst position modulation with time-hopping (BPM-TH) → non-coherent Rx
 - Low-complexity binary BCH codes
- Wide range of data rates are supported: 129 kbps to 9.65 Mbps
- Supports for 12 simultaneously operating piconets

Summary and Conclusions

- Complete impulse radio UWB PHY proposal optimized for BAN
- Reuse the strengths of 802.15.4a PHY as much as possible
- Proposed a new frequency band plan → simplifies receiver, no DAA requirements
- New symbol structure, time-hopping sequence → eliminates ISI w/o needing a GI
- Low complexity and low power-consumption standard
 - Binary burst position modulation with time-hopping (BPM-TH) → non-coherent Rx
 - Low-complexity binary BCH codes
- Wide range of data rates are supported: 129 kbps to 9.65 Mbps
- Supports for 12 simultaneously operating piconets

Acronyms and Abbreviations

- BCH Code Bose, Ray-Chaudhuri, Hocquenghem Code
- BPM Burst Position Modulation
- DAA Detection And Avoidance
- FCS Frame Check Sequence
- FEC Forward Error Correction
- GI Guard Interval
- HCS Header Check Sequence
- ISI Inter-Symbol Interference
- LDC Low Duty Cycle
- LFSR Linear Feedback Shift Register
- MAC Media Access Control
- PDP Power Decay Profile
- PHY Physical Layer
- PLCP Physical Layer Convergence Protocol
- PPDU Physical Layer Protocol Data Unit
- PRF Pulse Repetition Frequency
- PSDU Physical Service Data Unit
- SFD Start-of-Frame Delimiter
- SOP Simultaneously Operating Piconet
- TH Time-Hopping
- UWB Ultra-Wide Band

Backup

Better Channel Efficiency with Proposed Symbol Structure

- 15.4a symbol structure

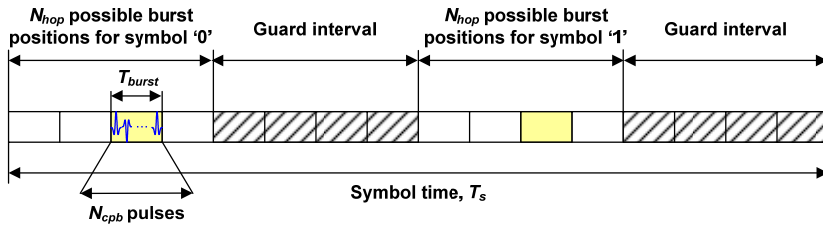

- Proposed symbol structure: N_{hop} doubled

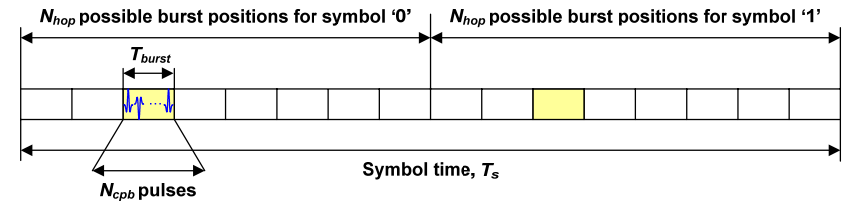

- Proposed symbol structure: data rate doubled

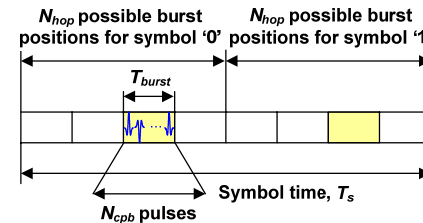

* For all the cases, the number of chips per burst N_{cpb} is the same.

Time-Hopping Sequence Generation (2)

- Conditional distributions from simulation: $N_{hop} = 8$ and $N_{ch} = 4$

