

Project: IEEE P802.15 Working Group for Wireless Personal Area Networks (WPANs)

Submission Title: [PicoCast MAC Protocol]

Date Submitted: [8 March 2009]

Source: [S.M. Ryu, T.H.Kim, J.G.Han, D.Y.Kim, C.S.Eun, & H.S.Lee]

Company [Casuh, CNU, PicoCast Forum, ETRI]

Address [#813 Leaders B/D, 342-1, Bundang, Seongnam, Kyeonggi, 463-828, Korea]

Voice: [+82-31-709-5577, +82-2-2082-1264, +82-42-821-6862], FAX: [+82-31-709-5578]

E-Mail:[retaw@casuh.com, jhan@picocast.org, taehyung@casuh.com, dykim@cnu.kr, hsulee@etri.re.kr]

Re: [Contribution to IEEE 802.15.6 Meeting, March 2009]

Abstract: [PicoCast MAC protocol support most of WBAN requirements. Container (Synchronous Frame Set) concept is suitable to support user oriented service convergence and avoid mutual interference. PicoCast single MAC can support multi PHYs and scalable different speed.]

Purpose: [Proposal]

Notice: This document has been prepared to assist the IEEE P802.15. It is offered as a basis for discussion and is not binding on the contributing individual(s) or organization(s). The material in this document is subject to change in form and content after further study. The contributor(s) reserve(s) the right to add, amend or withdraw material contained herein.

Release: The contributor acknowledges and accepts that this contribution becomes the property of IEEE and may be made publicly available by P802.15.

PicoCast MAC Protocol

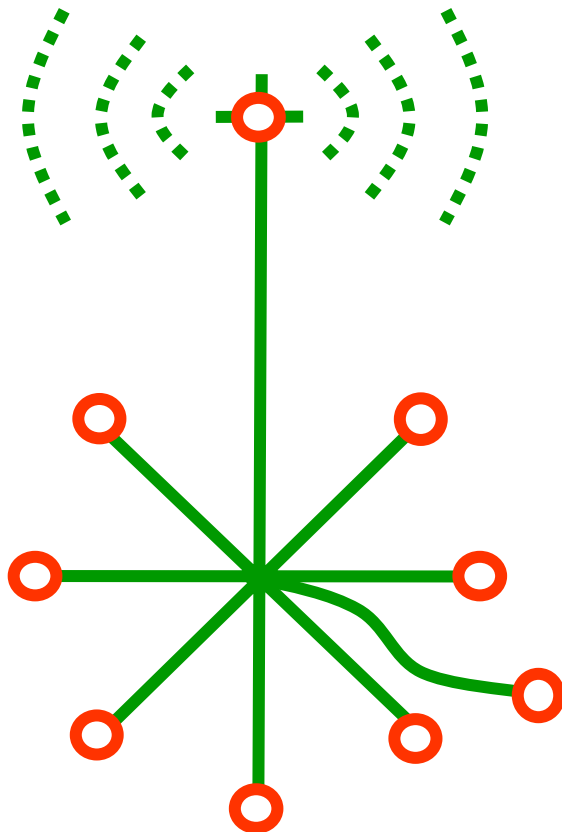

March 2009

S. M. Ryu, T. H. Kim
CASUH Corp.

J. G. Han
PicoCast Forum

D. Y. Kim, C.S. Eun
CNU

H. S. Lee
ETRI

Mark 4:3~9

- (4:3) 『"Listen! A farmer went out to plant some seed.』
- (4:4) 『As he scattered it across his field, some seed fell on a footpath, and the birds came and ate it.』
- (4:5) 『Other seed fell on shallow soil with underlying rock. The plant sprang up quickly,』
- (4:6) 『but it soon wilted beneath the hot sun and died because the roots had no nourishment in the shallow soil.』
- (4:7) 『Other seed fell among thorns that shot up and choked out the tender blades so that it produced no grain.』
- (4:8) 『Still other seed fell on fertile soil and produced a crop that was thirty, sixty, and even a hundred times as much as had been planted." Then he said,』
- (4:9) 『"Anyone who is willing to hear should listen and understand!"』

Spread Spectrum History

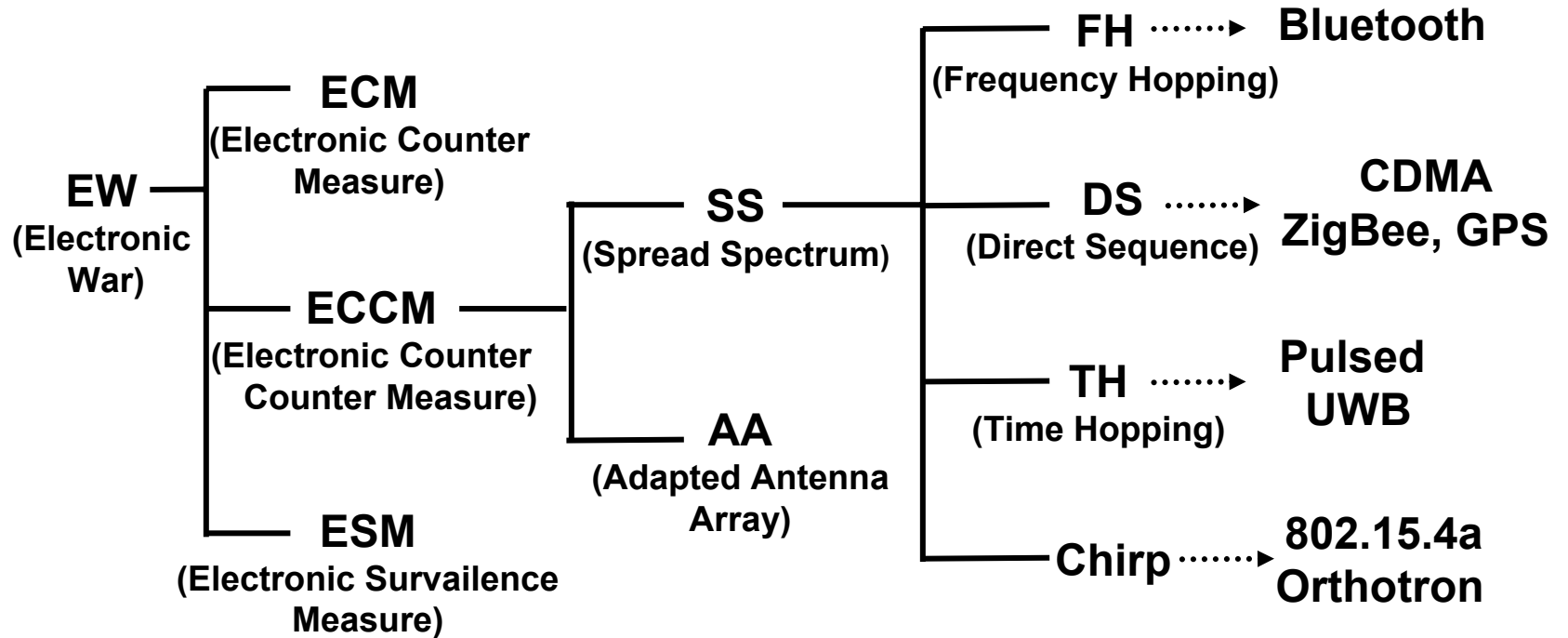

Military : Anti-jamming

Commercial : High Capacity

PicoCast

TDMA , OFDM

PicoCast MAC Position

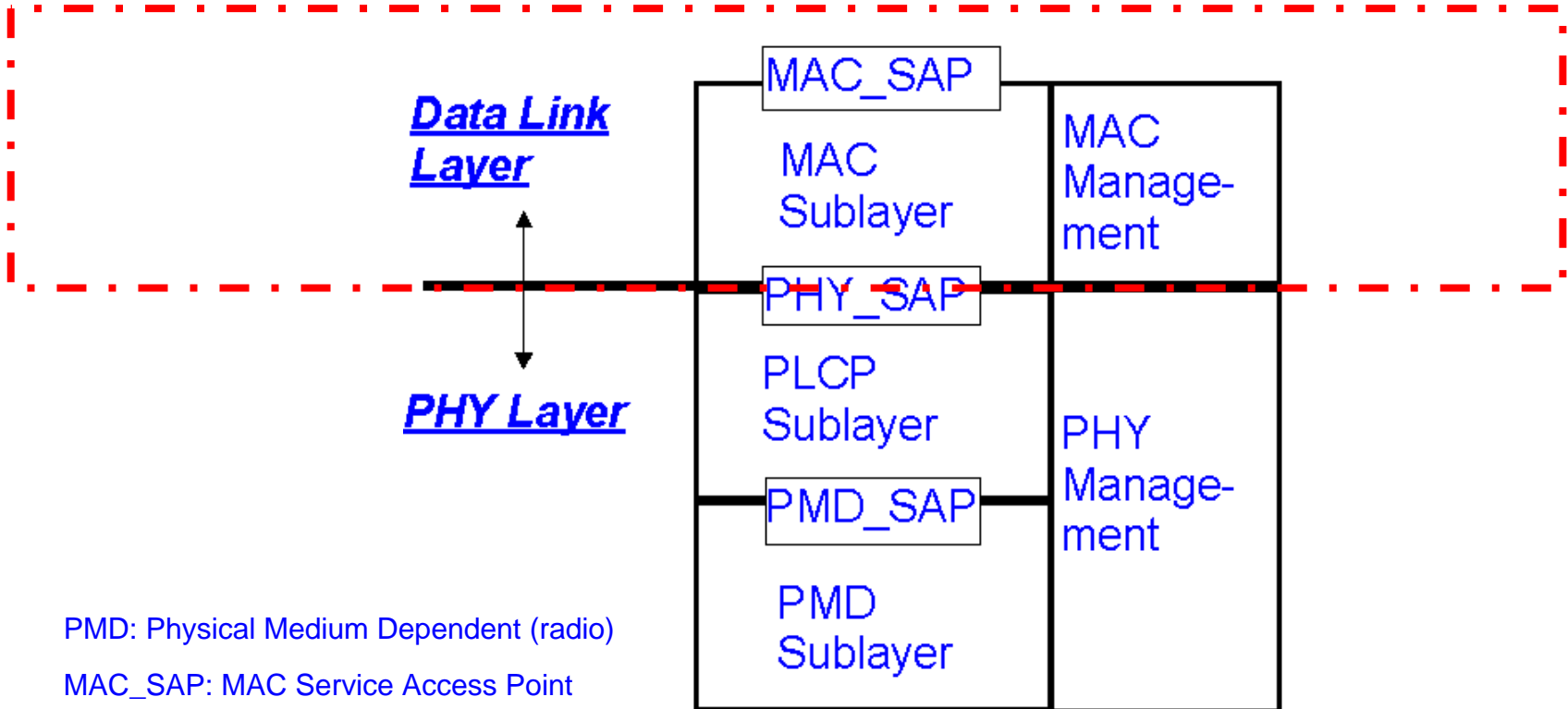

PMD: Physical Medium Dependent (radio)

MAC_SAP: MAC Service Access Point

PHY_SAP: PHY Service Access Point

PLCP: PHY Layer Convergence Protocol

Issues in WBAN Work Scope

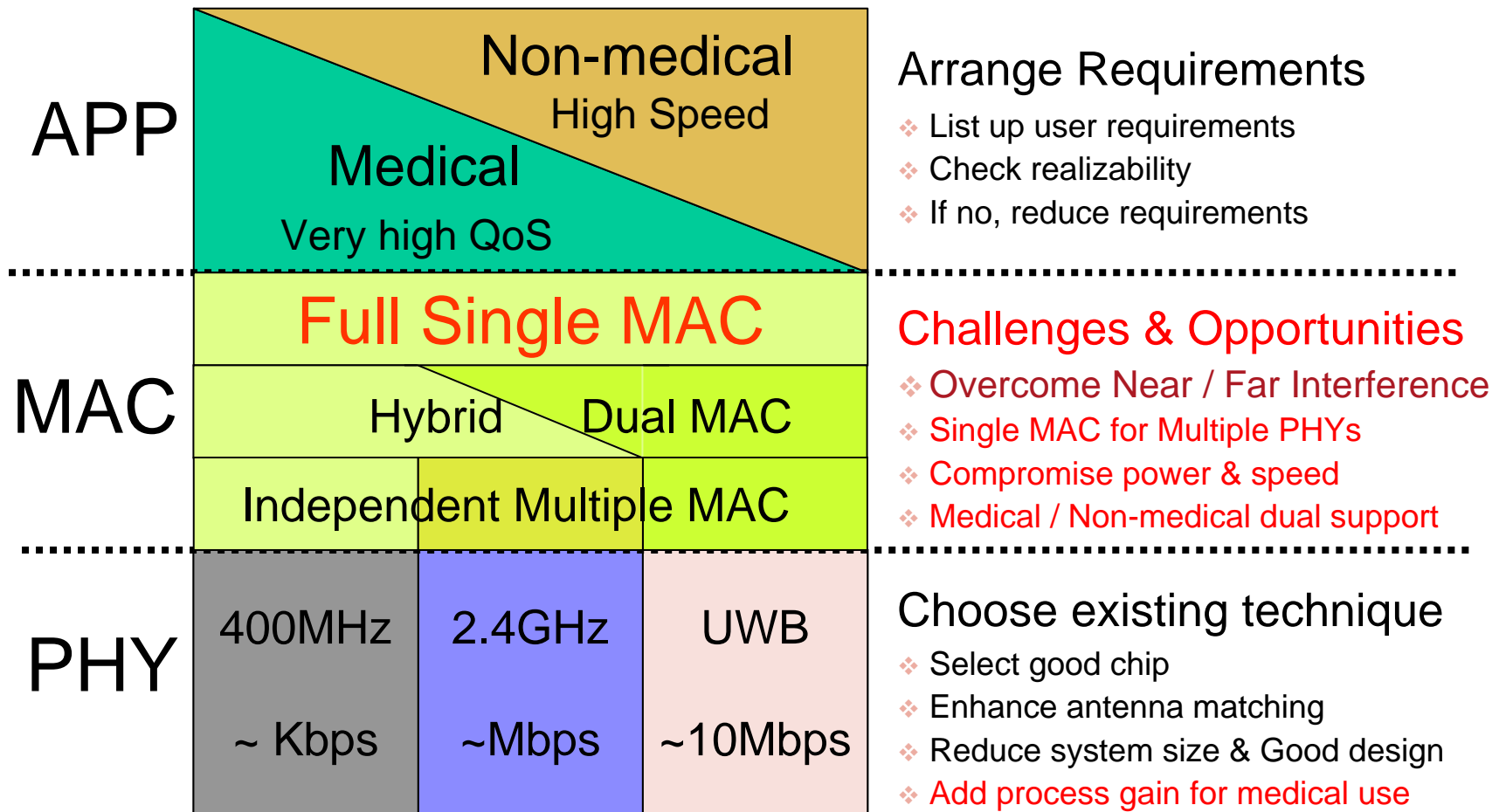

Solutions for Challenges

1. Near / Far Interference

- ❖ Chg. : Even though different frequency bands interfere each other
- ❖ Sol. : **Synchronized Frame** can reject mutual interference among PHYs
128bit multi preamble is necessary to enhance sync. probability

2. Single MAC to support Multi-PHYs

- ❖ Chg. : Single PHY cannot meet so wide user requirements
- ❖ Sol. : **Container Concept** accommodates various information **Boxes**
Synchronized Frame can support different PHYs without interference

3. Compromise Power & Speed

- ❖ Chg. : Low power sensor and High speed multimedia should be supported
- ❖ Sol. : Multi PHY concept can support **Multi RF Block**
Sensor use single RF Block, Multimedia use multi RF Block's

4. Medical / Non-Medical Dual support

- ❖ Chg. : Medical needs 10^{-10} BER performance with low speed
- ❖ Sol. : **128bit Multi preamble** provides **enough Process Gain**
We can use 128bit multi preambles as 1 or 4bit data symbols

PicoCast MAC Protocol Features

- ❖ **Single MAC for Multiple PHYs (1,2,3,10,11,12,14)**
 - Open structure for any PHY with the suggested interface.
 - Support time control for synchronized container concept.
- ❖ **Synchronized Container Concept (7,9,10,11,13,14)**
 - Sensor, data, & multimedia box's can be shipped within a same container
 - Every same size container should be synchronized to avoid interference
 - Every container must reserve the first slot for the control box.
- ❖ **128bit length Multiple Preambles (3,4,5,6,7,9,10,12,13,14)**
 - 127 Preambles(128bits length) are used for different usages.
 - Emergency, short command, synchronization, priority, hand-over & etc
 - Support data integrity for important medical information as 1bit symbol
- ❖ **Hierarchical Code structure & Self Frequency Planning (1,6,7,8,9,13,14)**
 - Group Code, Scan Code, & Security Code are used for various applications.
 - Scan Code supports sounding algorithm to choose the best frequency set.
- ❖ **Adaptive Common Channel Signaling (7,8,9,10,12,13,14)**
 - 16 containers are composed to one vessel(256msec).
 - Control Boxes are used for adaptive common channel signaling

PHY(RF) independent MAC (Baseband)

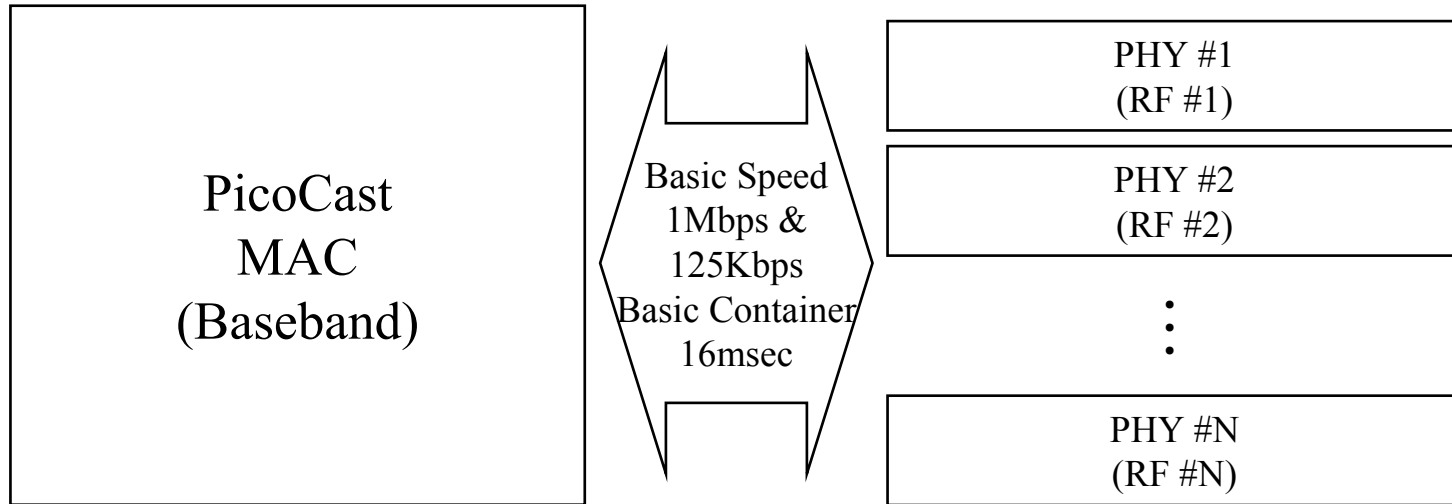

- ❖ **PHY Type** : 2.4G RF, UWB, WMTS, MICS, & etc.
- ❖ **PHY Interface** : Synchronized Container Base
- ❖ **Basic Speed** : 1Mbps (125Kbps for MICS)
- ❖ **Special Features** :
 - Container Synchronized Interference Rejection
 - Scalable data rate depend on PHY

PHY(RF) Requirements

- ❖ Shall satisfy WBAN Requirement
(TG6 Technical Requirements Document)
- ❖ Support the operation of Box structure
 - Box Size : 400 μ sec ~ 15.2msec
 - Basic Data Rate : 1Mbps
 - Scalable Data Rate : 250K,500K,1M, 2M,4M,8M,16Mbps (option)
 - Lock Time : Less than 500 μ sec (230 μ sec recommended)
 - End of Box (EOB) : Less than 300 μ sec (40 μ sec recommended)
 - Operation Mode : Tx / Rx / Idle / Sleep / Power-off
 - Write Parameters : Frequency, Power Level
 - Read Parameters : RSSI, Frequency Drift
 - Clock Stability : Less than 20ppm
- ❖ Special Requirements for low speed MICS Frequency
 - Basic Data Rate : 125Kbps
 - Minimum Box Size : 1.3msec (single Command Box)
 - Linear Modulation to achieve spread spectrum process gain
 - Control Box slot would be reserved for future usage

Example of PHY Interface with SPI

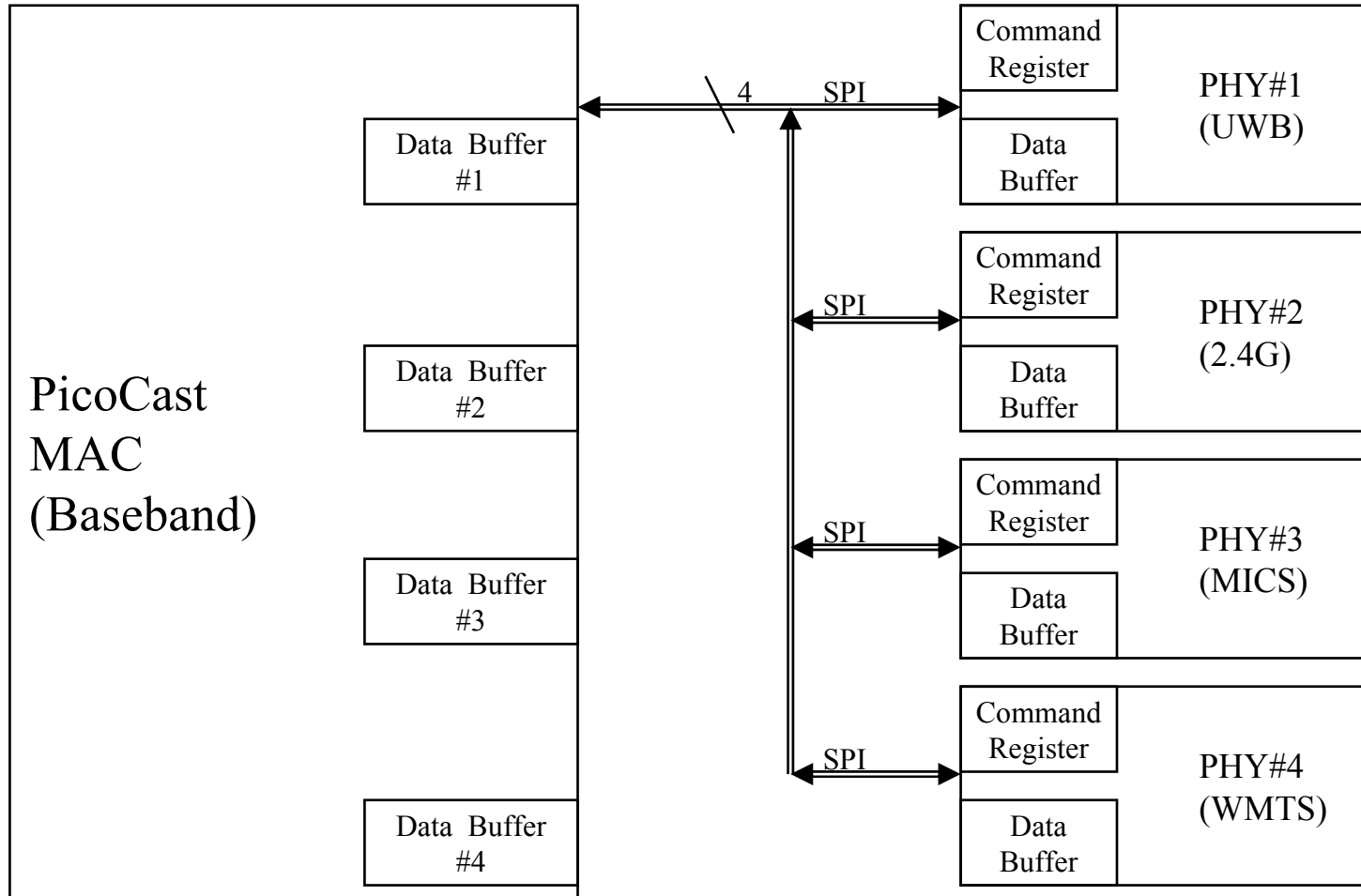

Example of Multi RF Application

- Frequency Diversity
- High speed Tx with narrow band RF
- Low Power Sensor uses single RF

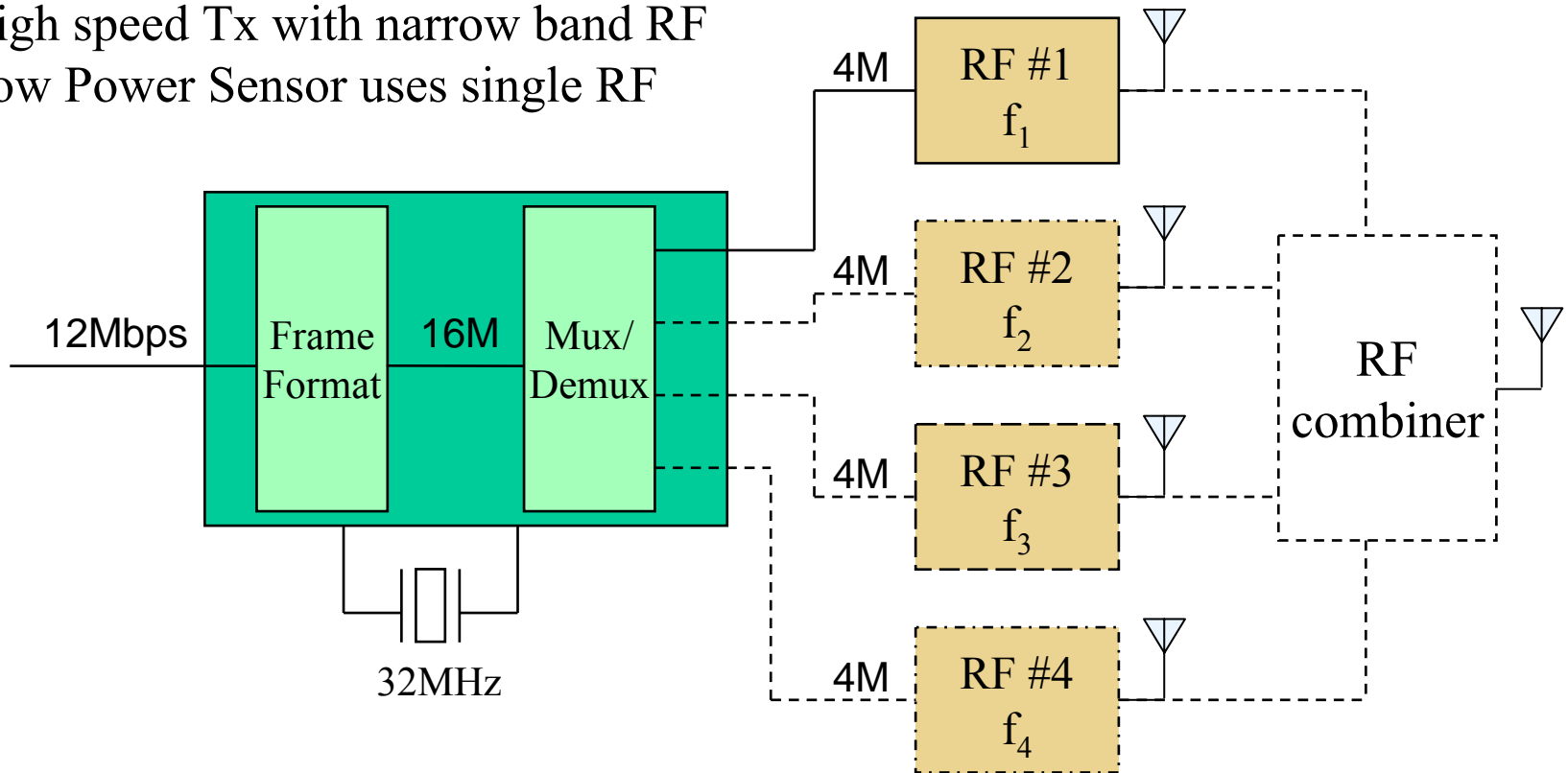

Near / Far Interference

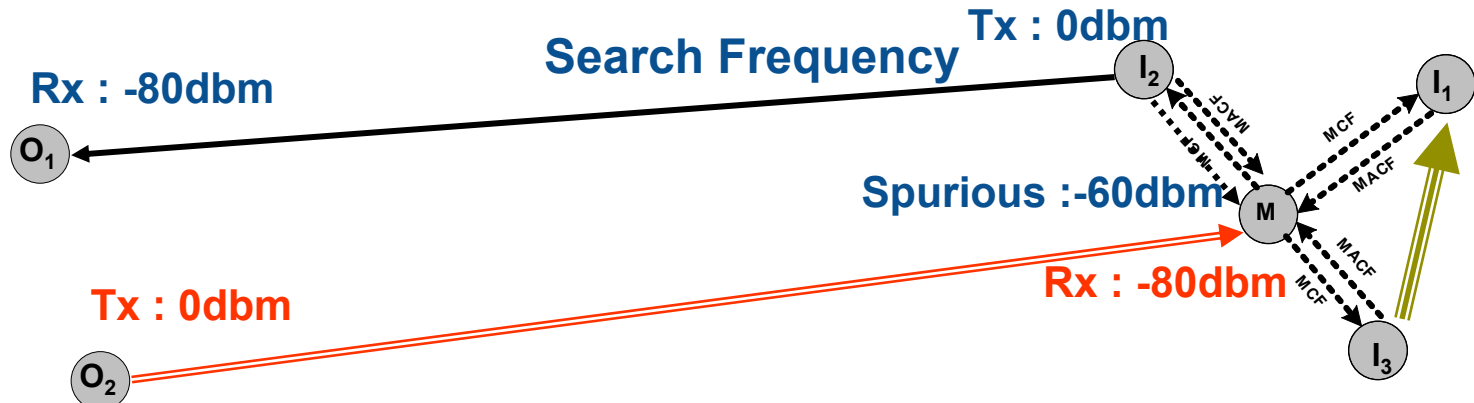

Shall not receive during other PHY is transmitting

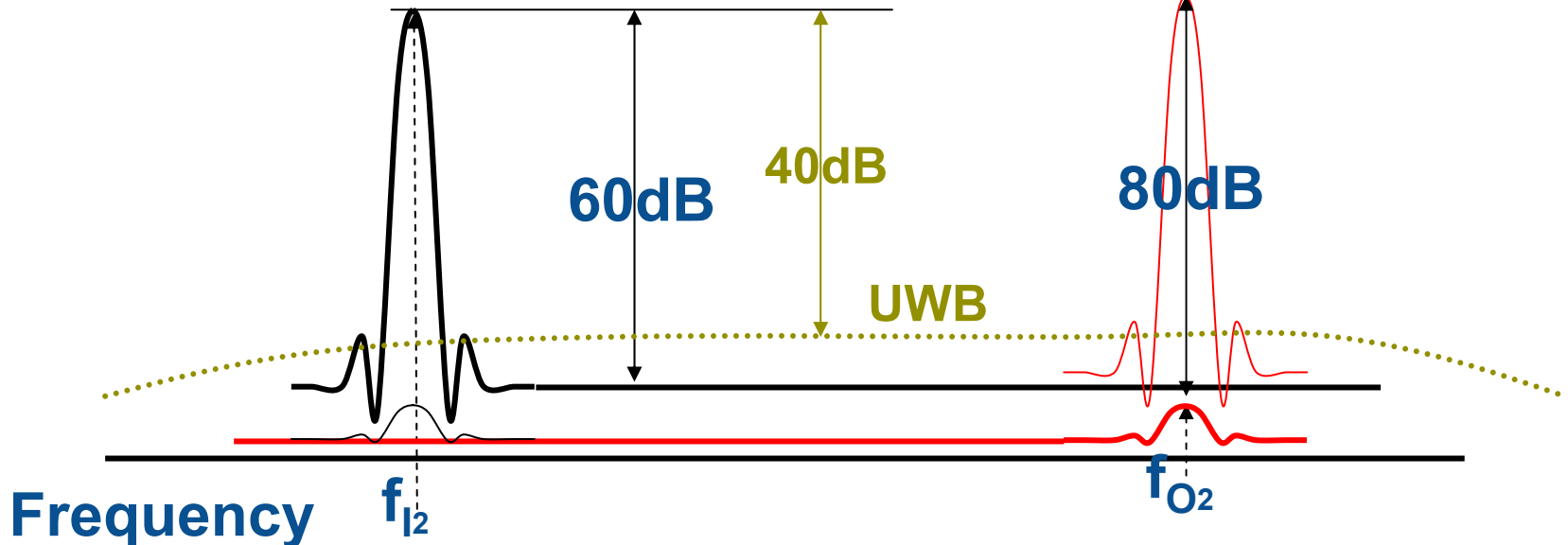

Mutual Interference of existing solution

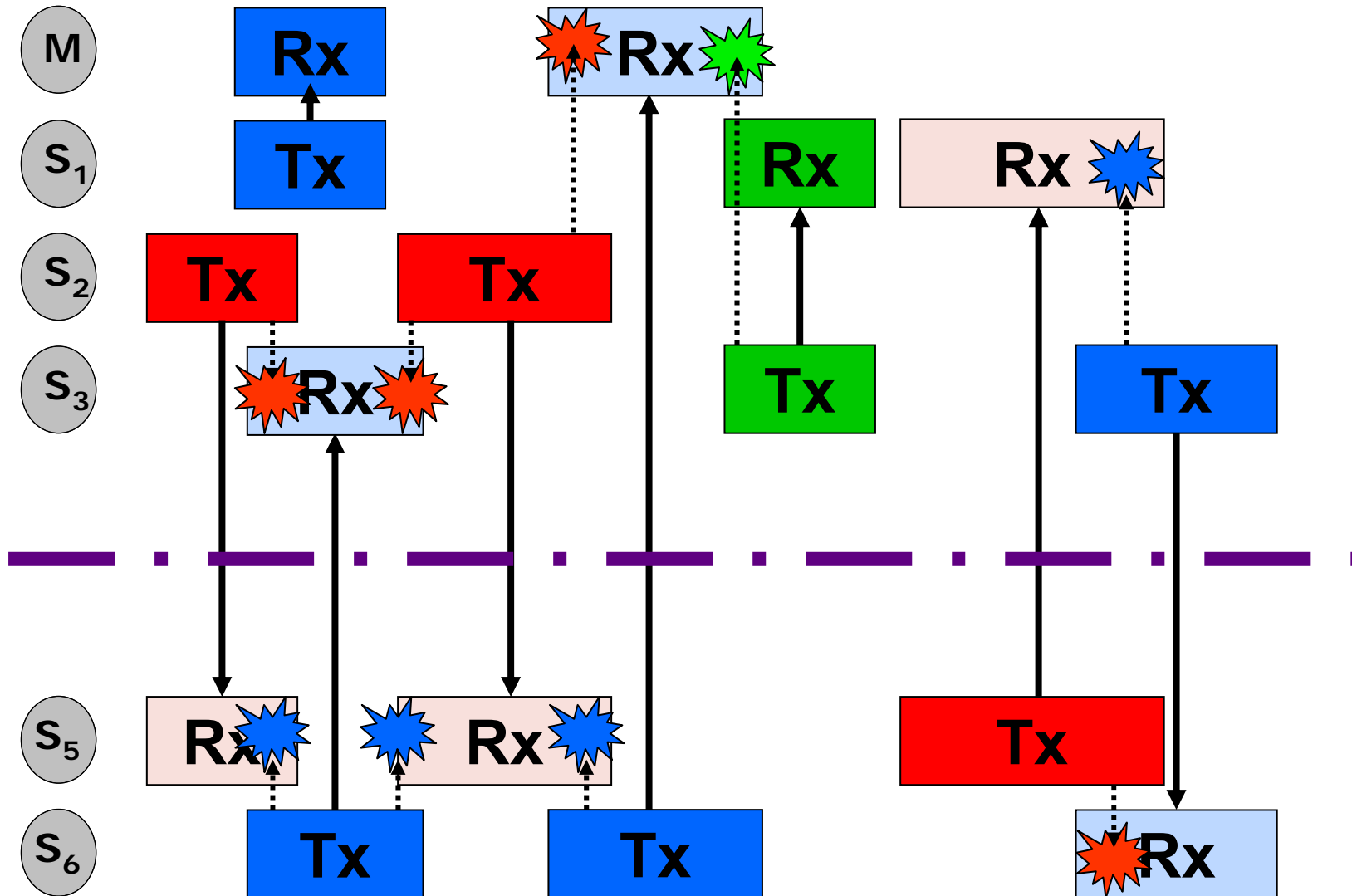

How to avoid mutual interference

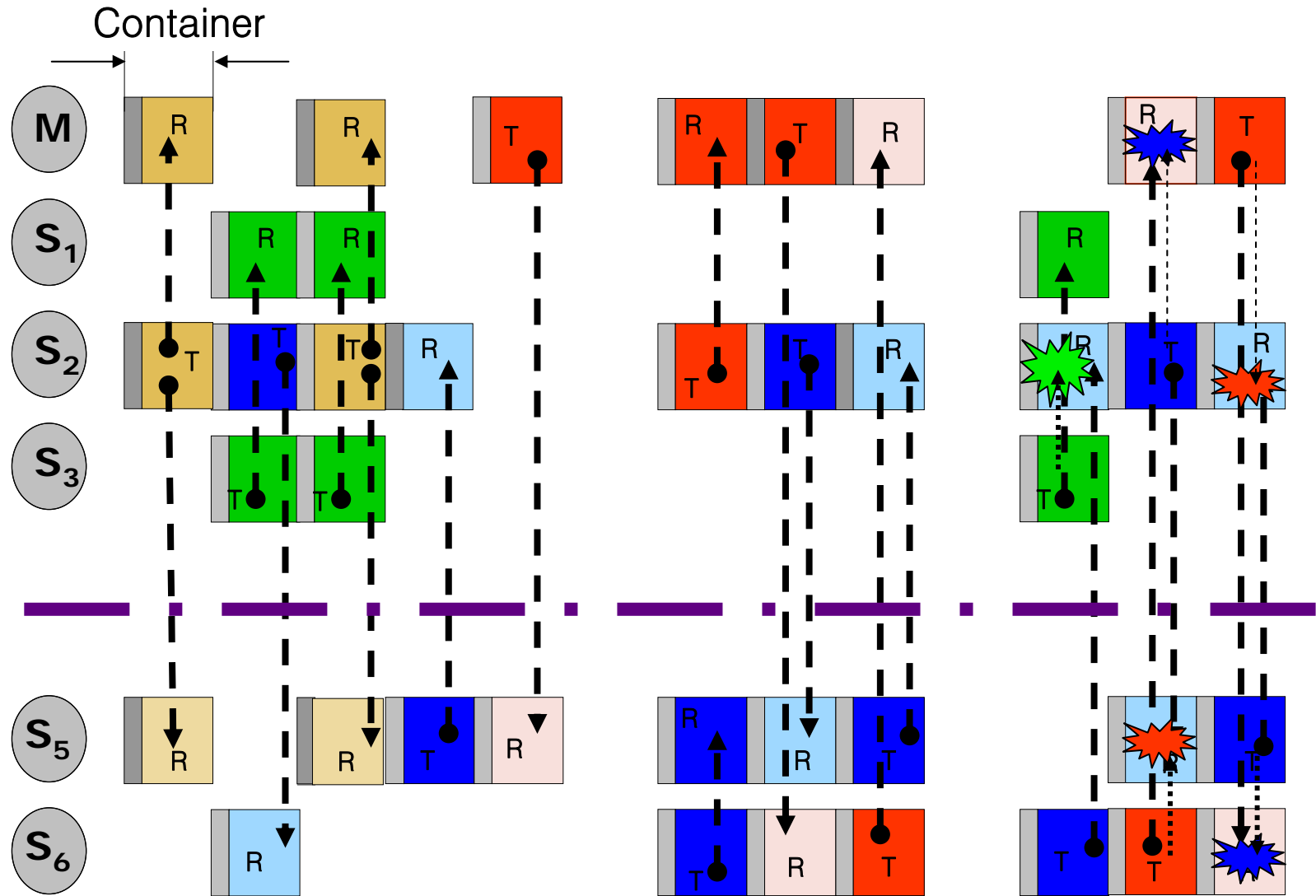

Body Coordinator → Mobile Femto-cell

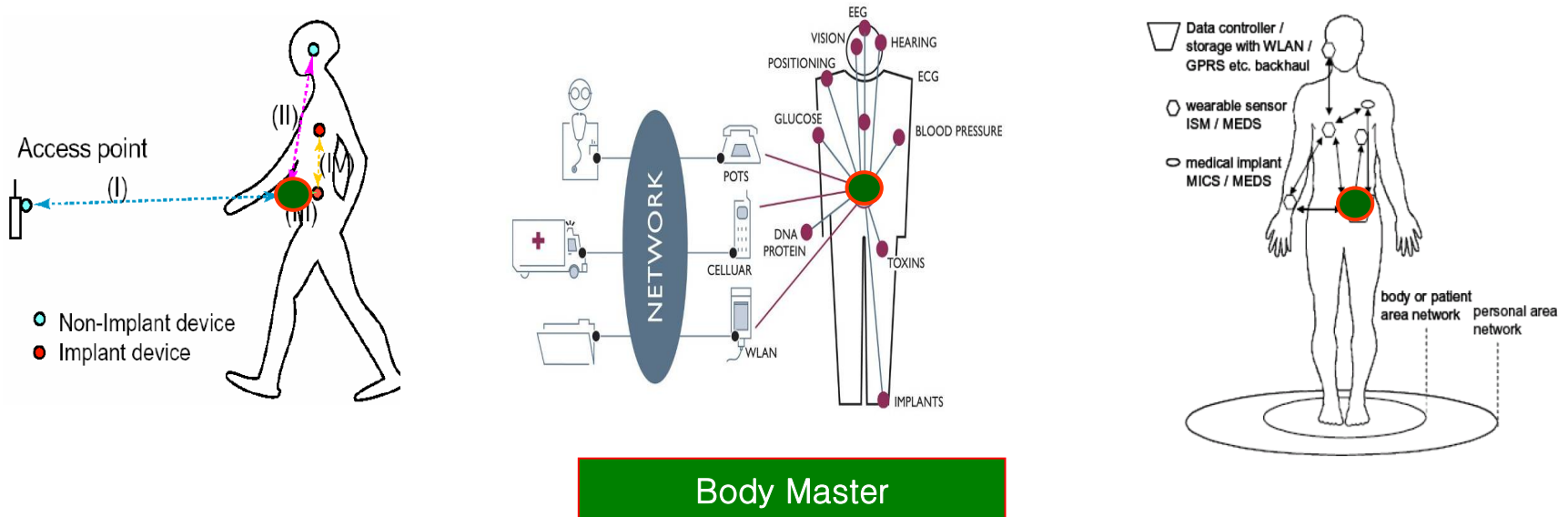

- ❖ **Body coordinator is not a suitable concept.**
 - Synchronous frames can reject mutual interference among RFs .
 - So, Body coordinator should synchronize all of body devices.
- ❖ **Better to rename body coordinator as “Body Master”.**

Synchronized Container Concept

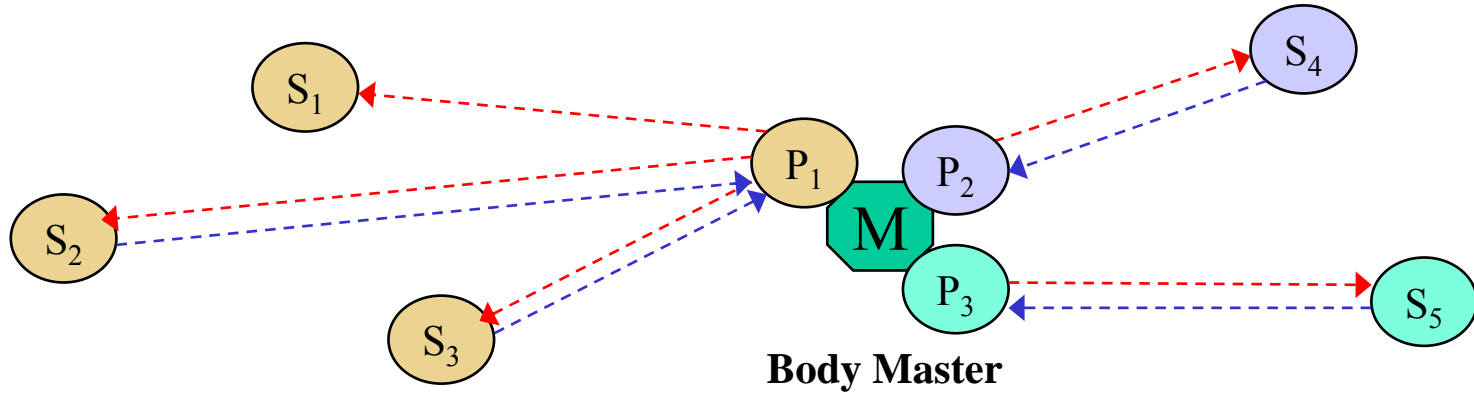

PHY # 1	Tx	Idle	Idle	Idle	Idle	Rx	Idle	Rx
PHY # 2	Tx	Rx	Idle	Tx	Rx	Rx	Idle	Rx
PHY # 3	Idle	Rx	Idle	Tx	Idle	Rx	Tx	Rx

- ❖ **Avoid mutual interference among PHYs in body master**
 - **Shall not receive during other PHY is transmitting.**
 - **Transmit together at the same time.**
- ❖ **Low speed MICS ignores control box time slot (Non Beacon Mode)**

Paradigm Shift : User Oriented

Provider Oriented

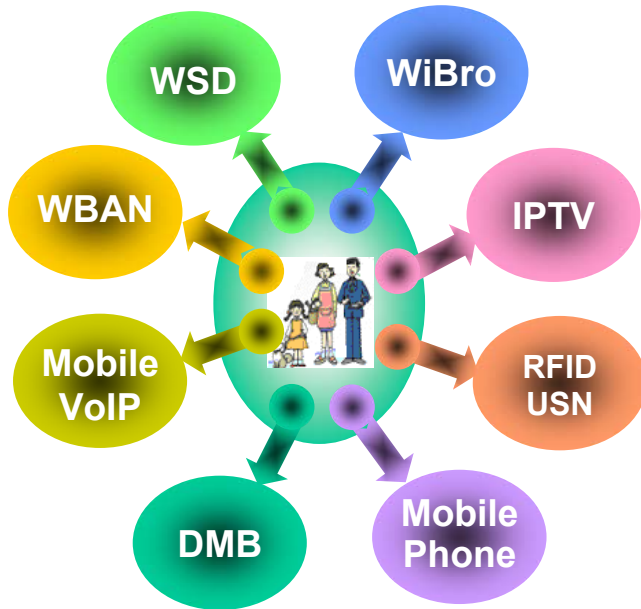

User terminals should meet provider specifications

User Oriented

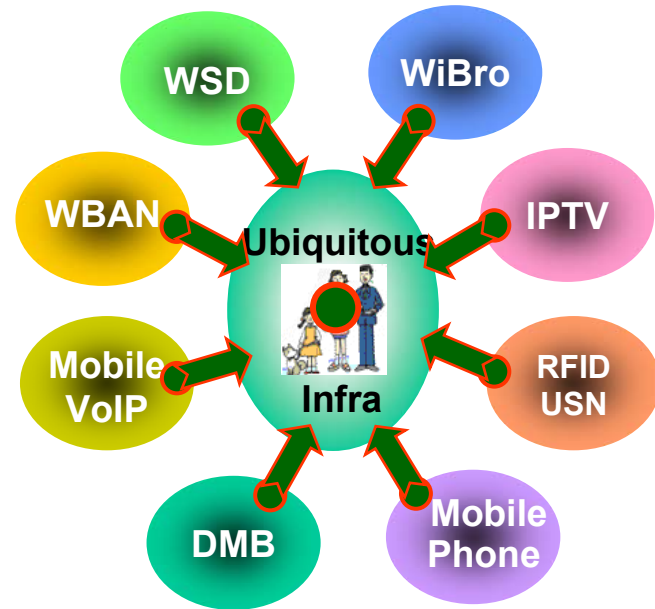

Users select among services broadcast by providers

Market Initiative ⇒ WBAN

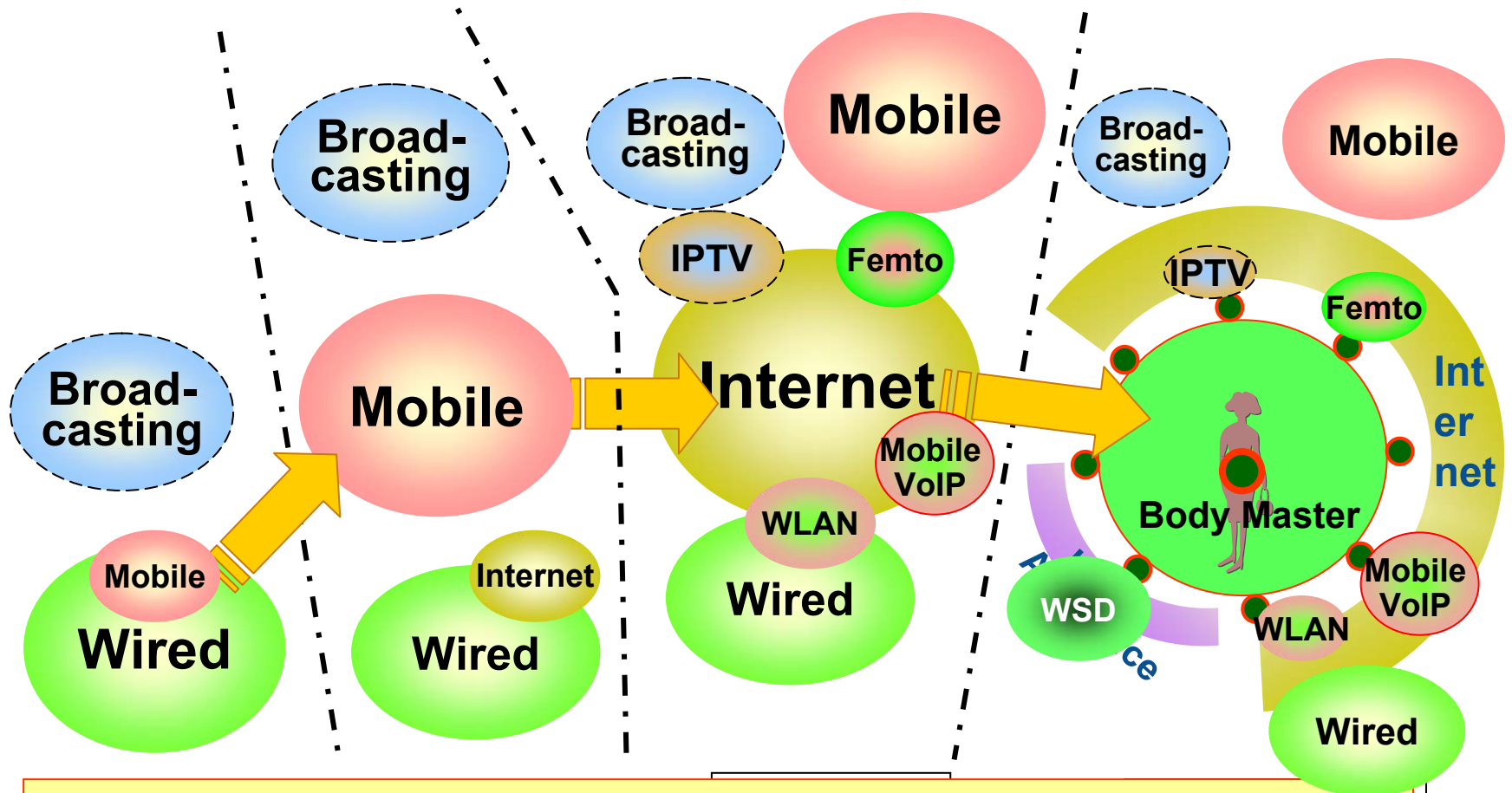

User oriented Ubiquitous ⇒ Mobile Femto-cell ⇒ WBAN

Mobile Femto-cell = Body Master

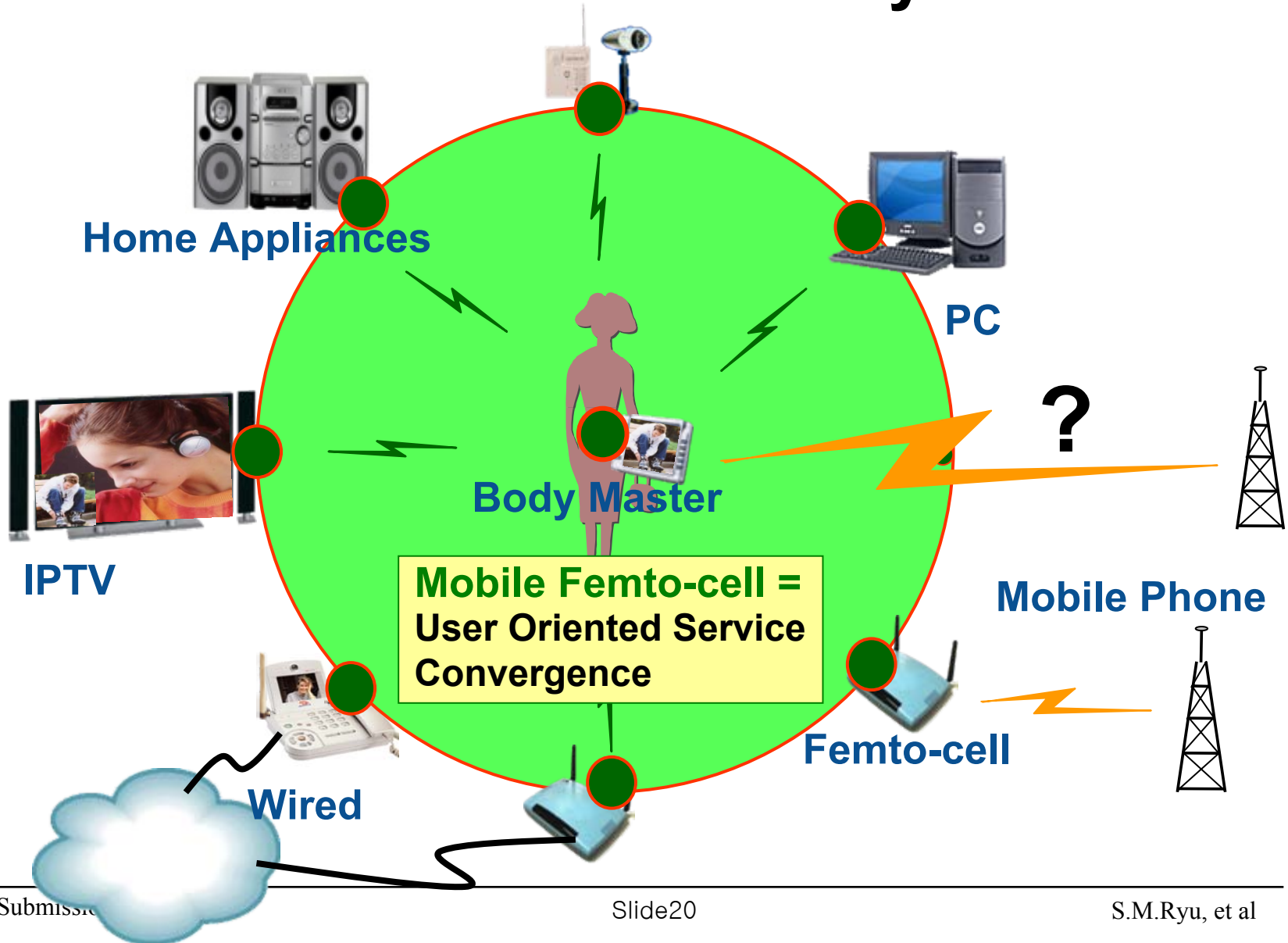

5G : Personal Mobile Space

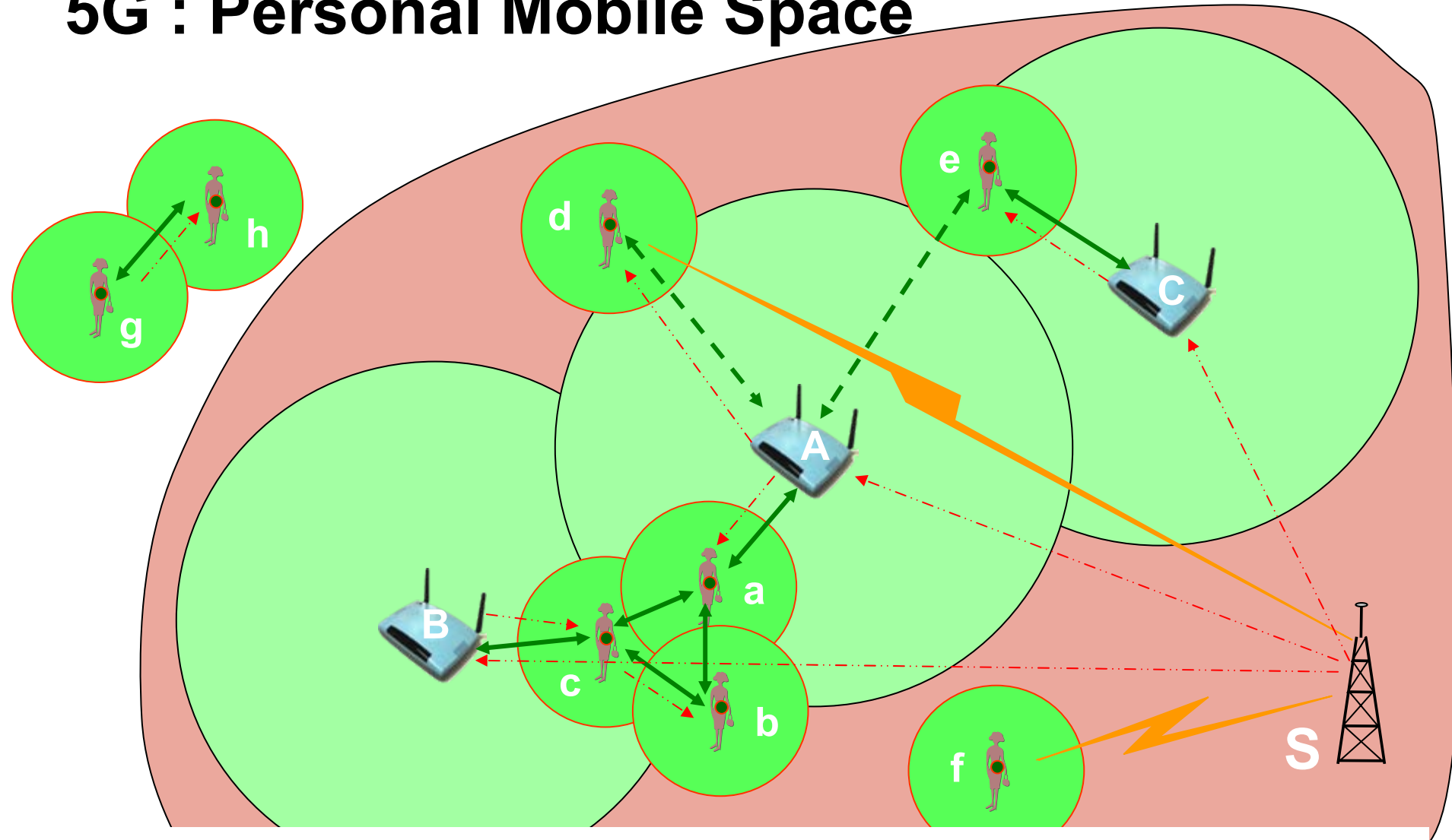

To reduce mutual interference, perfect synchronization is necessary

Hierarchical Sync Structure

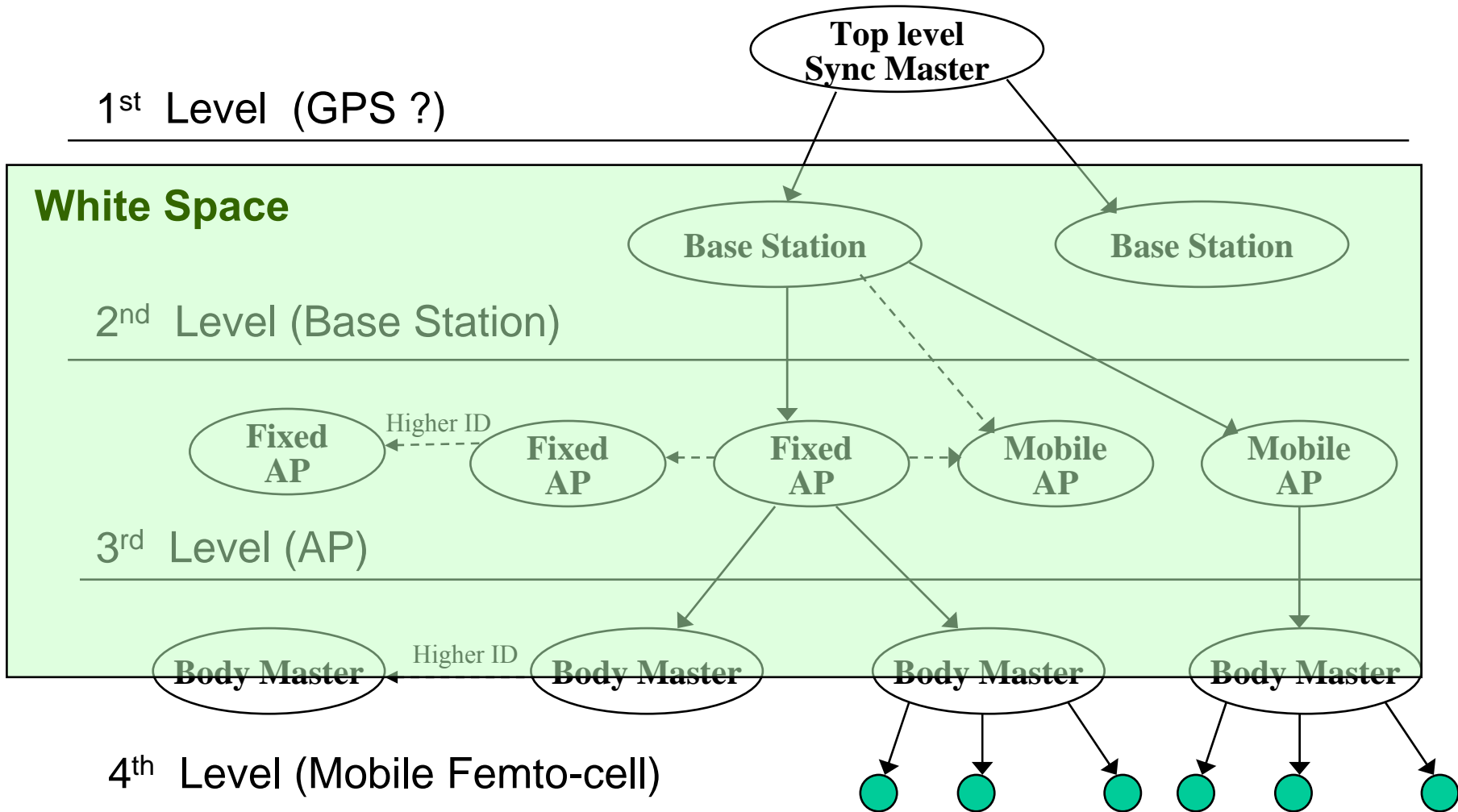

Ubiquitous Cell Planning

• 2-D

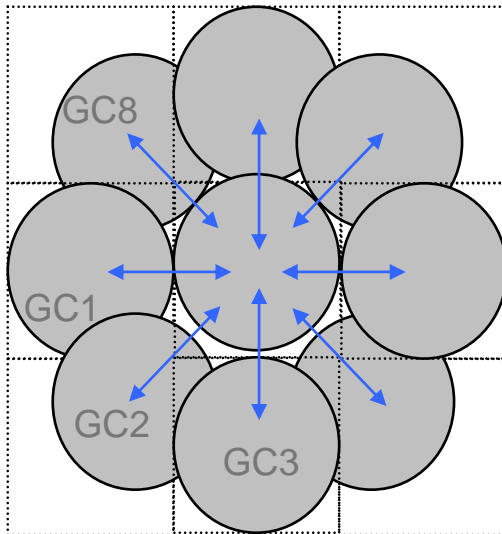

• 3-D

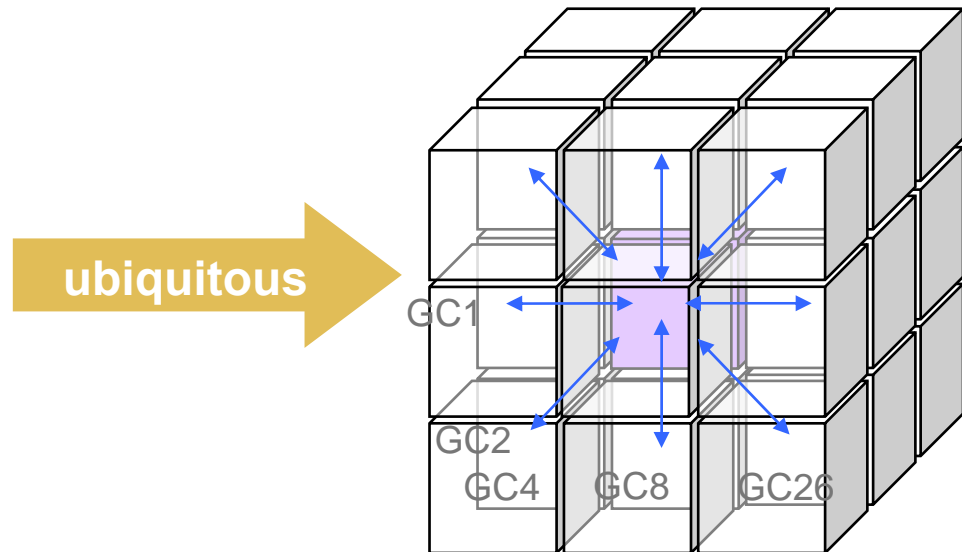

Self Organizing MAC is inevitable

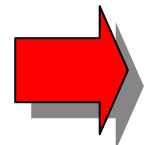

128bit Multi Preambles

False Alarm & False Dismissal Probability of 128bit preamble

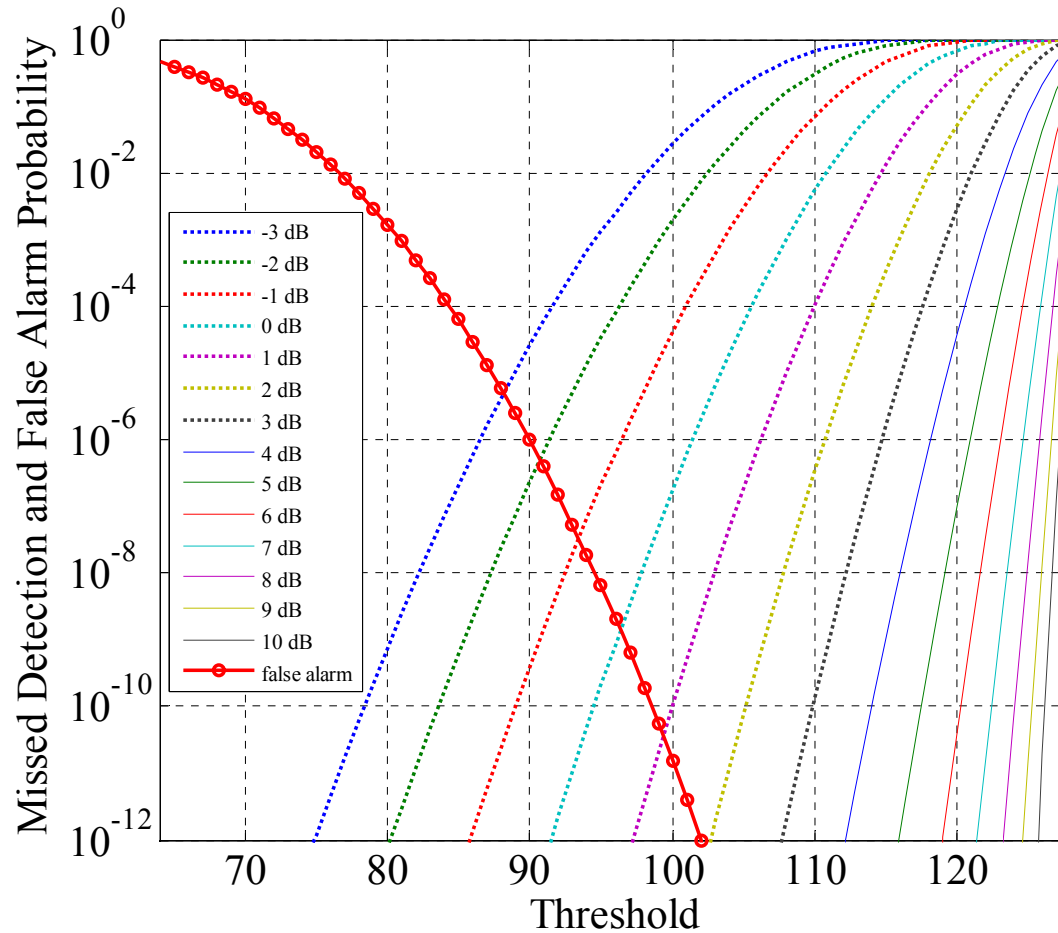

64bit is not enough but 128 bit is high enough ; so we suggest multi Preamble

Multiple Preamble Structure

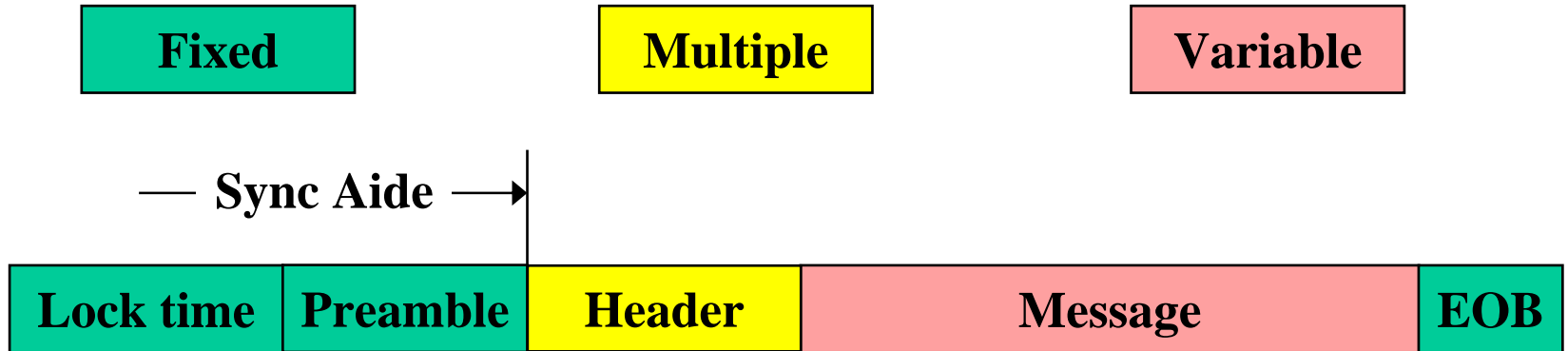

Conventional Frame Structure

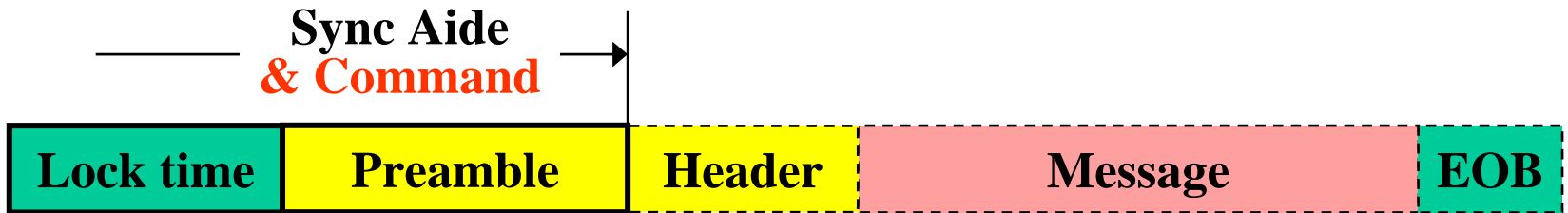

Suggested Frame Structure

Multiple Preamble contains short message

Basic Components of PicoCast MAC

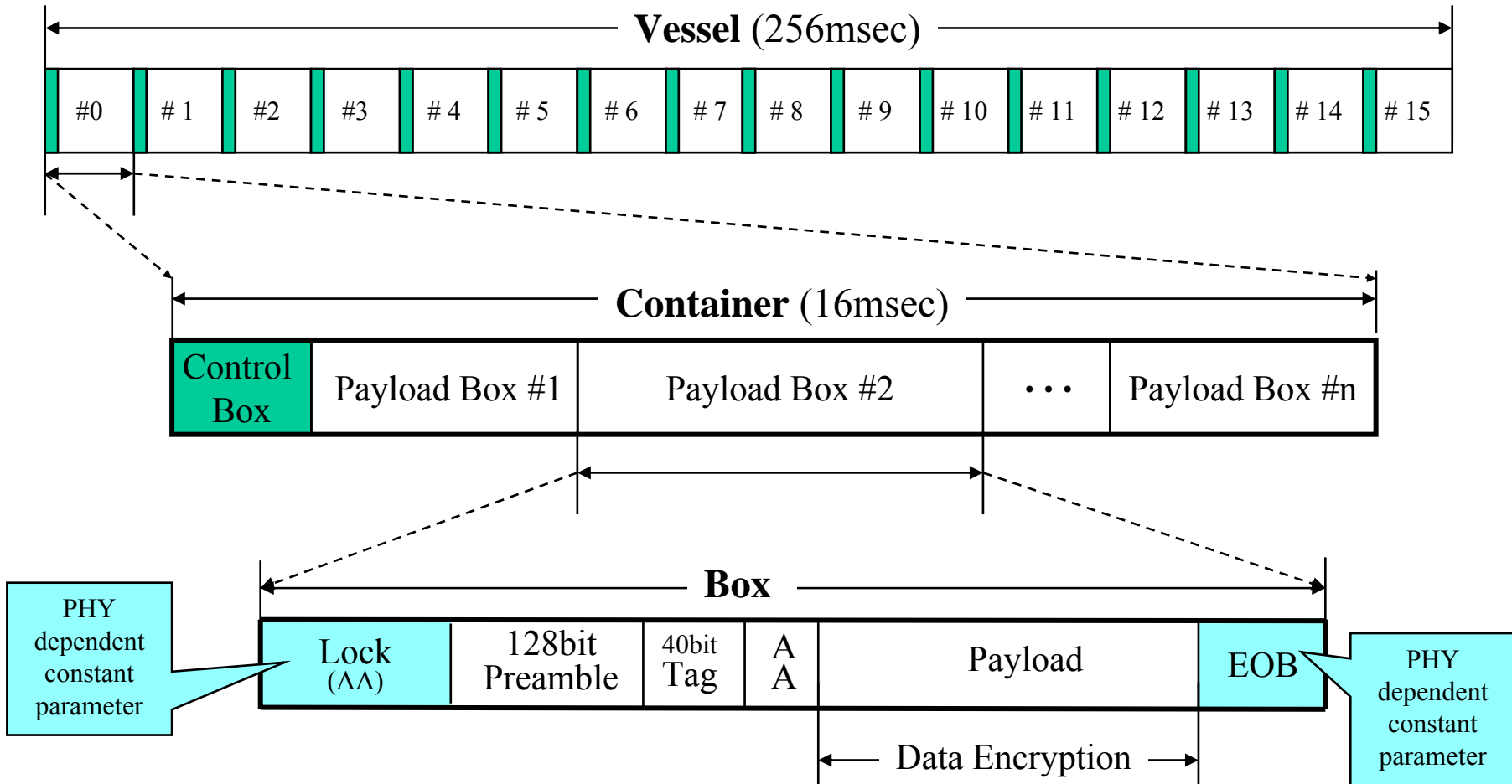

Example of Box Structure for different PHY

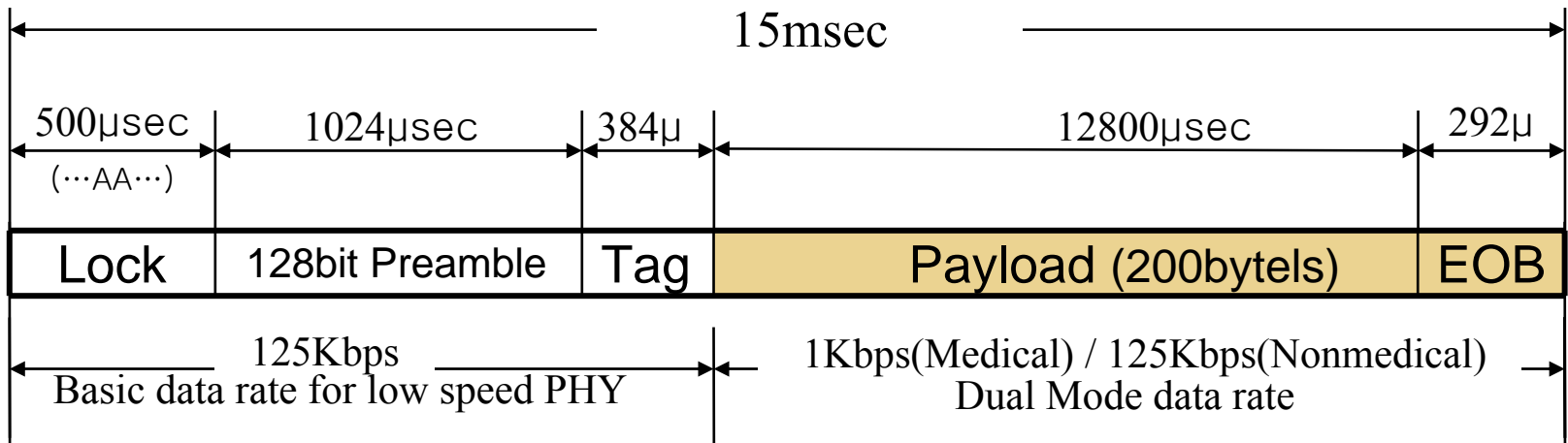
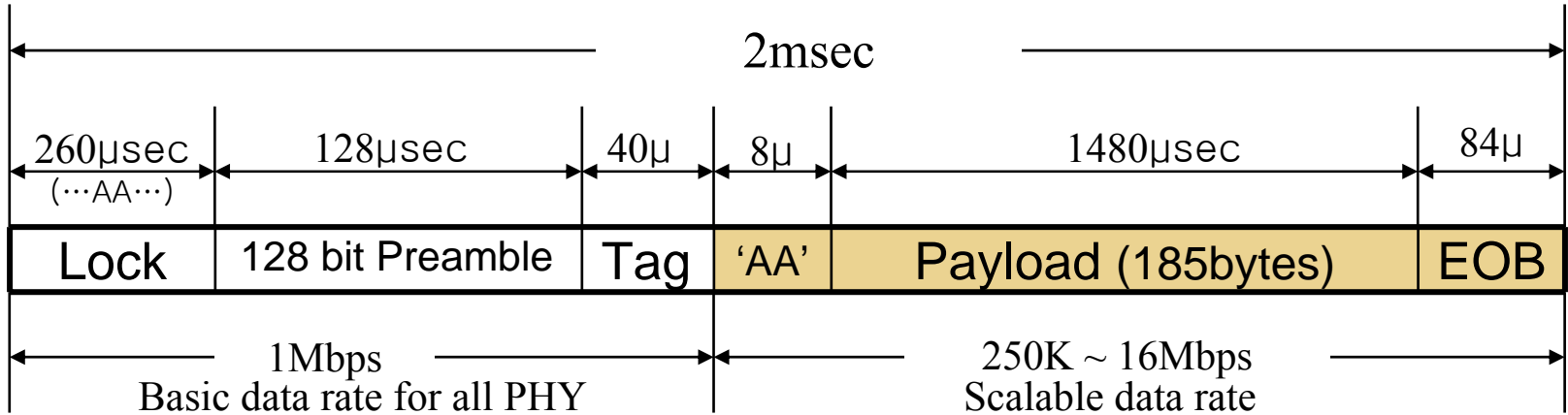

Example of Control box structure

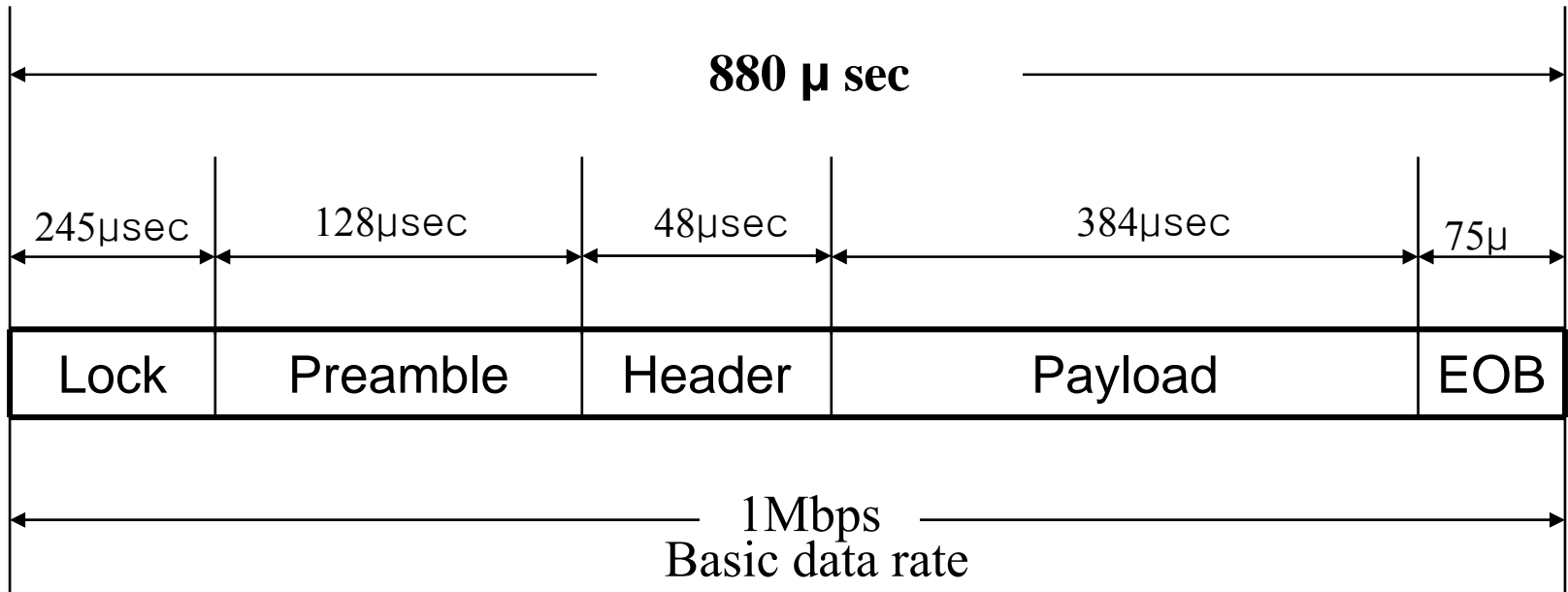

- Preamble : 128µsec : 128bits
- Header : 48µsec : 4Bytes + CRC16
- Payload : 384µsec : 46Bytes + CRC16

Multiple Preamble Generator

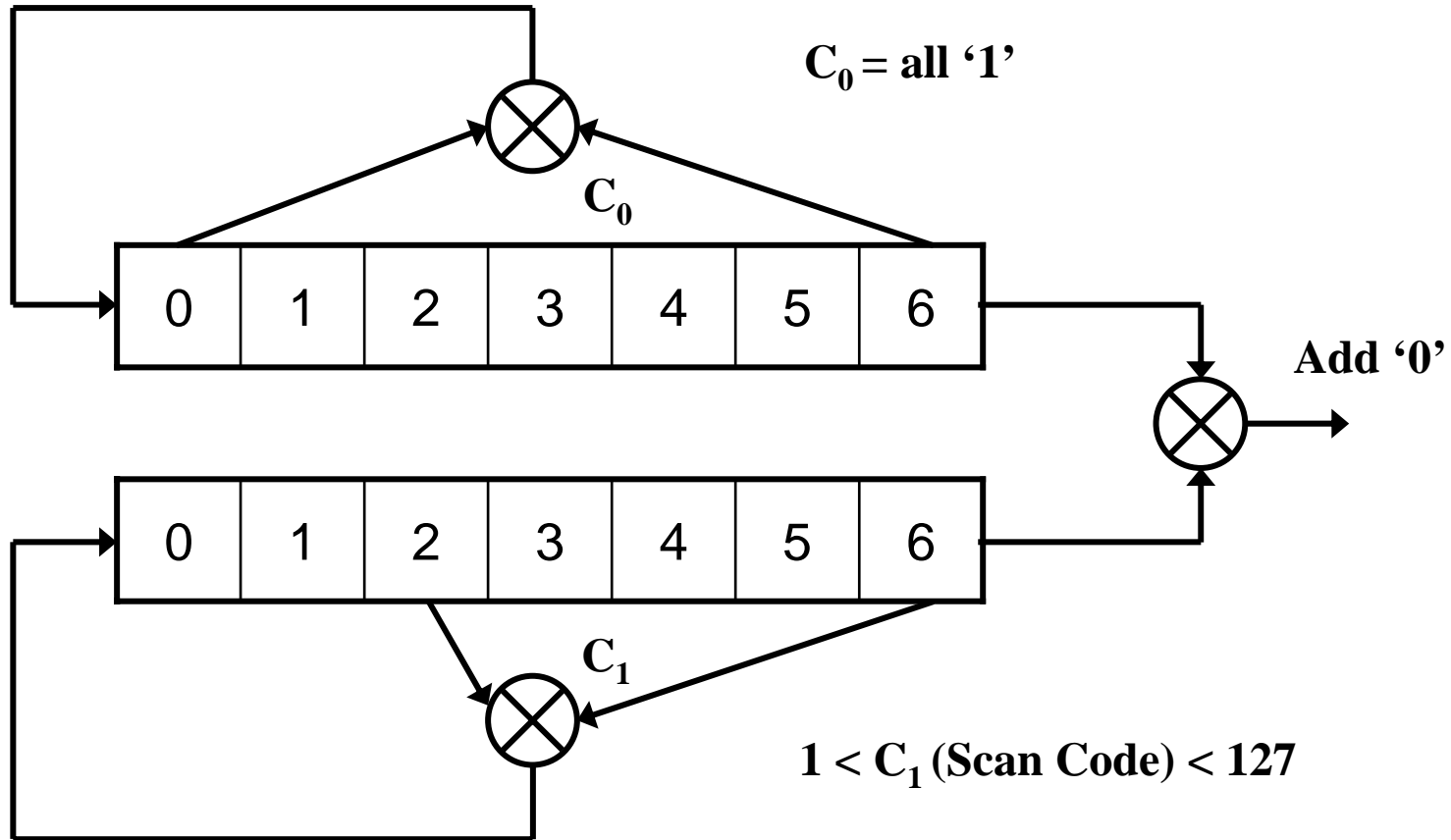

127bit Gold code Generation and '0' insertion

Multiple Preamble Usage

C_1	Remarks
1 ~ 8 (8)	General Box purpose (Control, Payload)
9 ~ 12 (4)	Hierarchy Beacon Box for synchronization
13 ~ 16 (4)	Pairing Box (Fast Beacon Box)
17 ~ 18 (2)	Sounding Box
19	Reliable Medical 1bit/symbol data transmit
20 ~ 35 (16)	Reliable Medical 4bit/symbol data transmit ※ would be substituted by the best code set after simulation study.
36 ~ 41 (16)	Hands over for the local broadcasting
42 ~ 49 (8)	Define Multi-RF to indicate sequence order
50 ~ 127 (except 119)	TBD ; waiting for MICS or special PHY applications
119	Emergency

Performance of 128bit Preamble Symbol

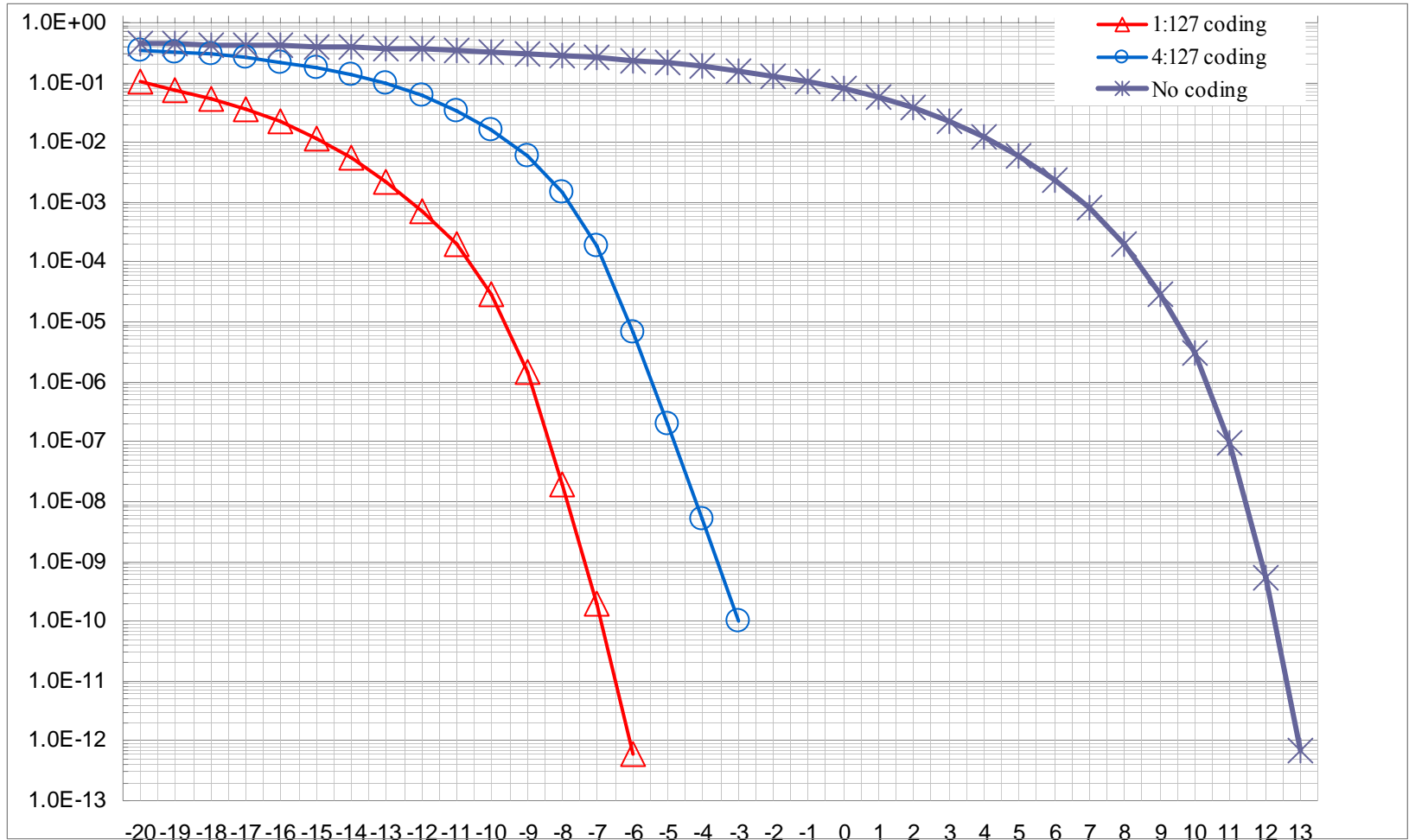

Code Types

Type	Bit	Description
Scan Code	7	C1, To generate multiple preamble
Group Code	64	To generate group encryption pattern
Security Code	16	To protect secure data among group
ID	64	Assigned to every device as serial number

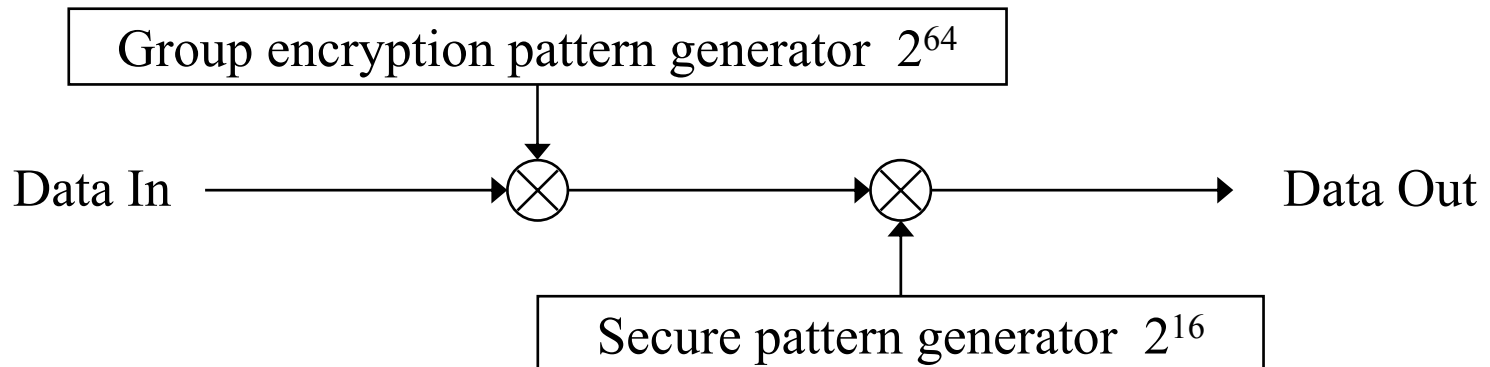

Code application for Box contents

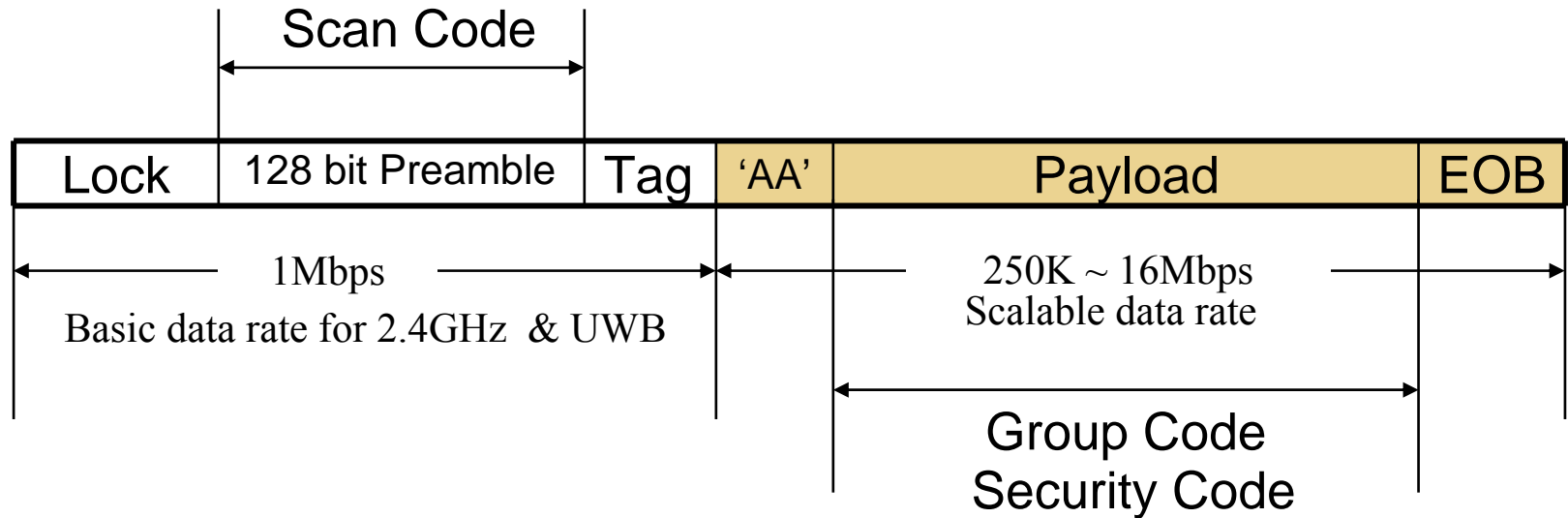

- ❖ **Group Code is used for payload data only.**
 - Different group can not communicate each other
 - 64bit ID of Master can be used as Group code
- ❖ **Security Code is set as '0' for normal communication**

Control Box for normal Vessel

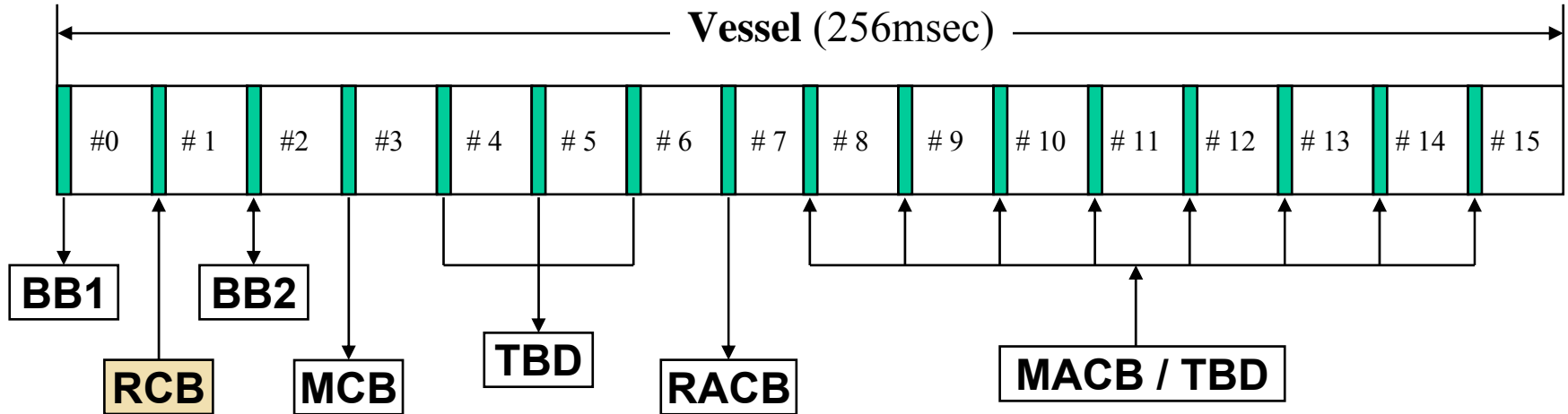

- ❖ **BB1** : Beacon Box 1, (Master Tx only)
- ❖ **BB2** : Beacon Box 2, (Master Tx, Rx Alternate for Sync Relay)
- ❖ **RCB** : Request Control Box ; **Contention permitted mode**
- ❖ **MCB** : Master Control Box
- ❖ **RACB** : RCB Acknowledge Control Box
- ❖ **MACB** : MCB Acknowledge Control Box

Control Box for fast sync Vessel

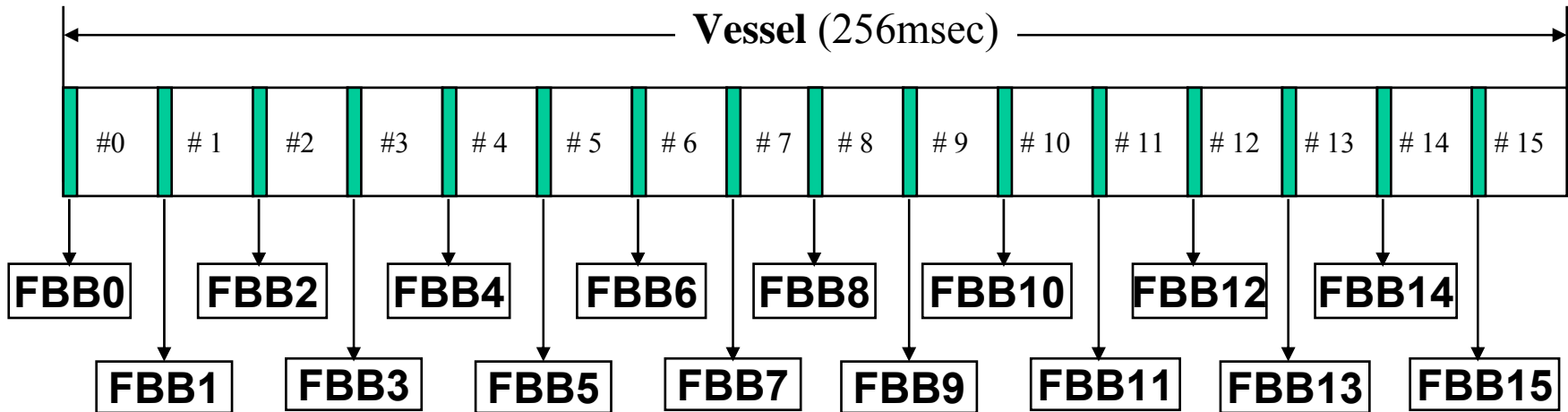

- ❖ **FBB : Fast Beacon Box**
- ❖ **16 frequencies are used for synchronization.**
- ❖ **FBB use special preamble assigned for fast paring**
- ❖ **Normally fast paring is done within 256msec**
- ❖ **Within 1sec paring requirement is realizable**

Vessel Mode Change

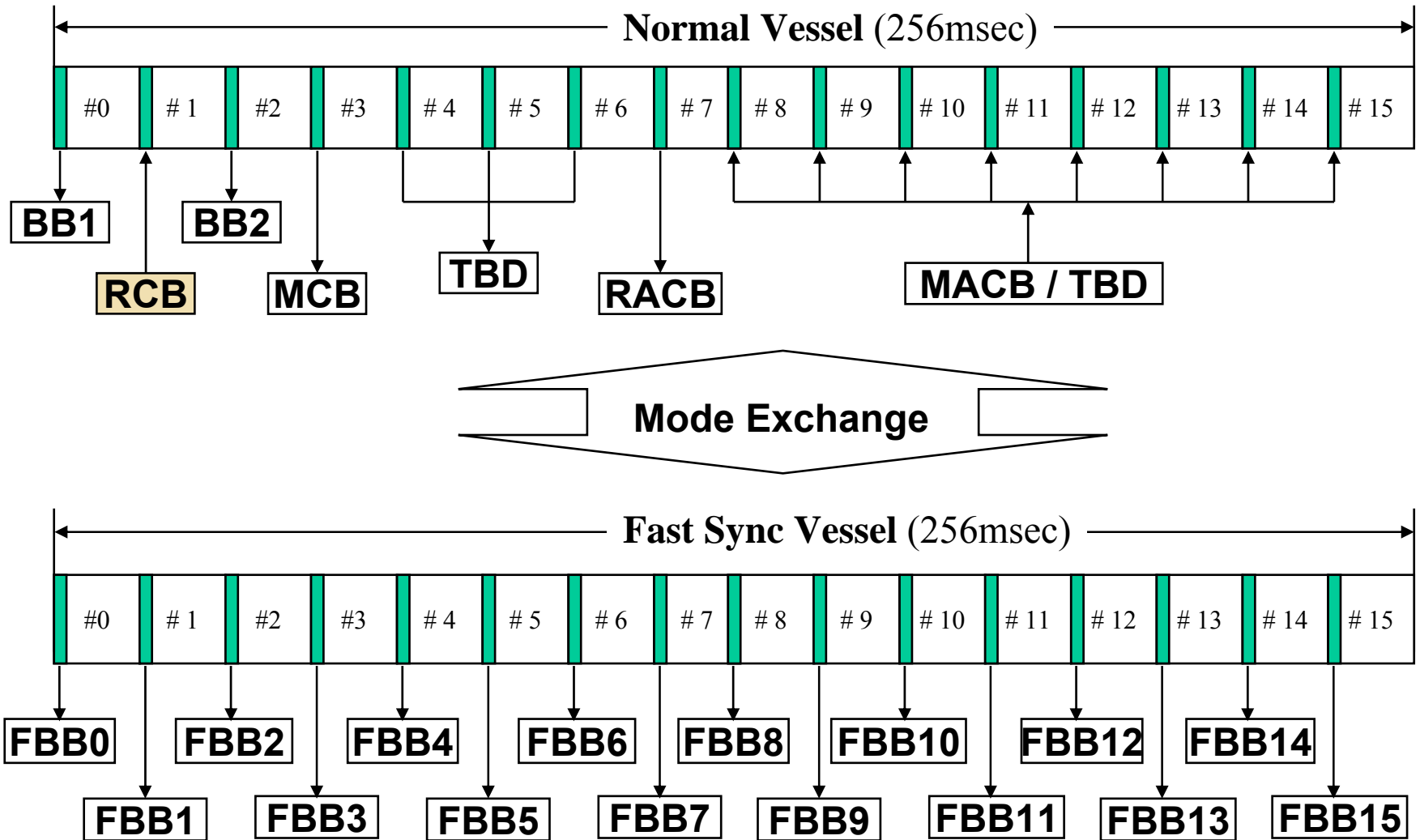

MCB Operation Example

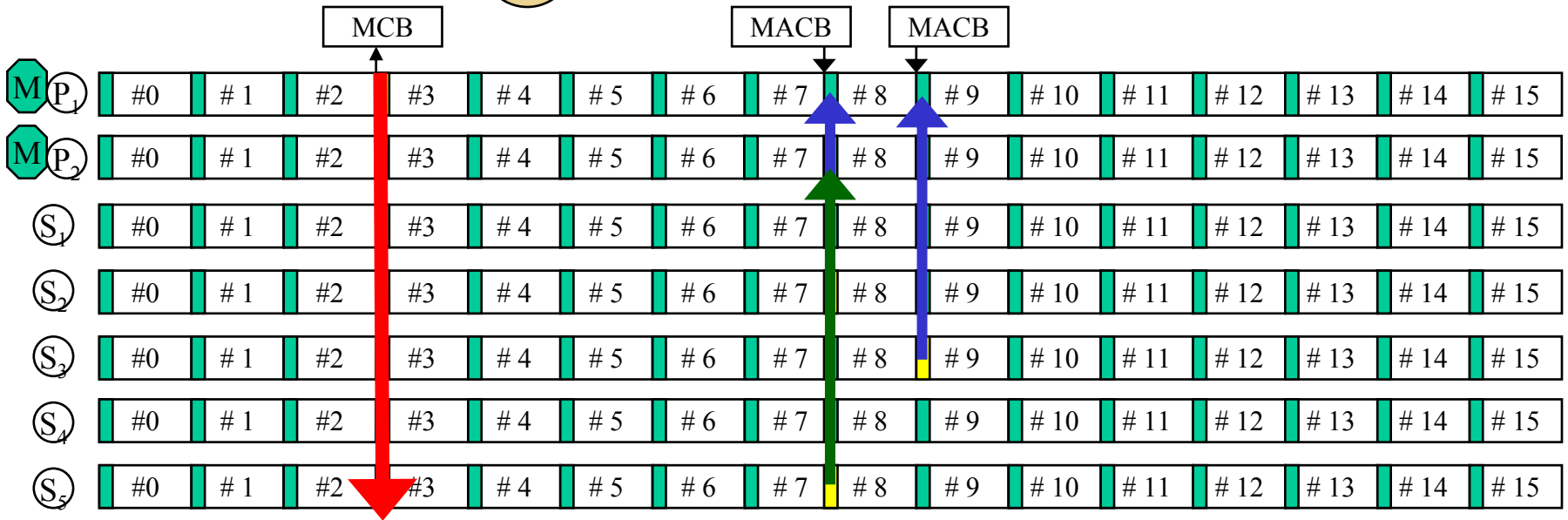
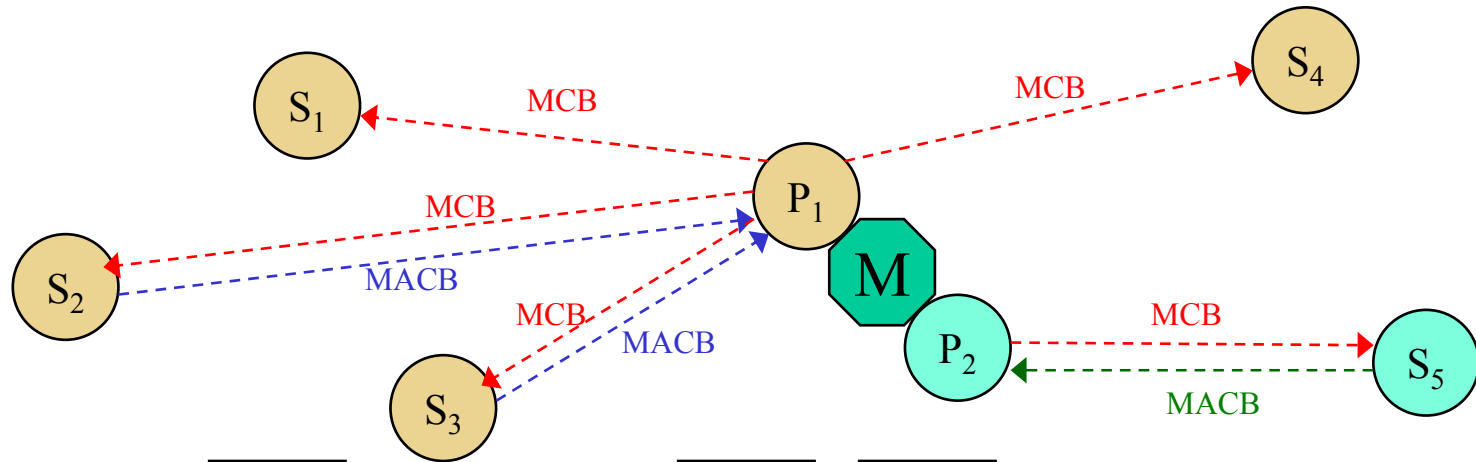

Paring Process

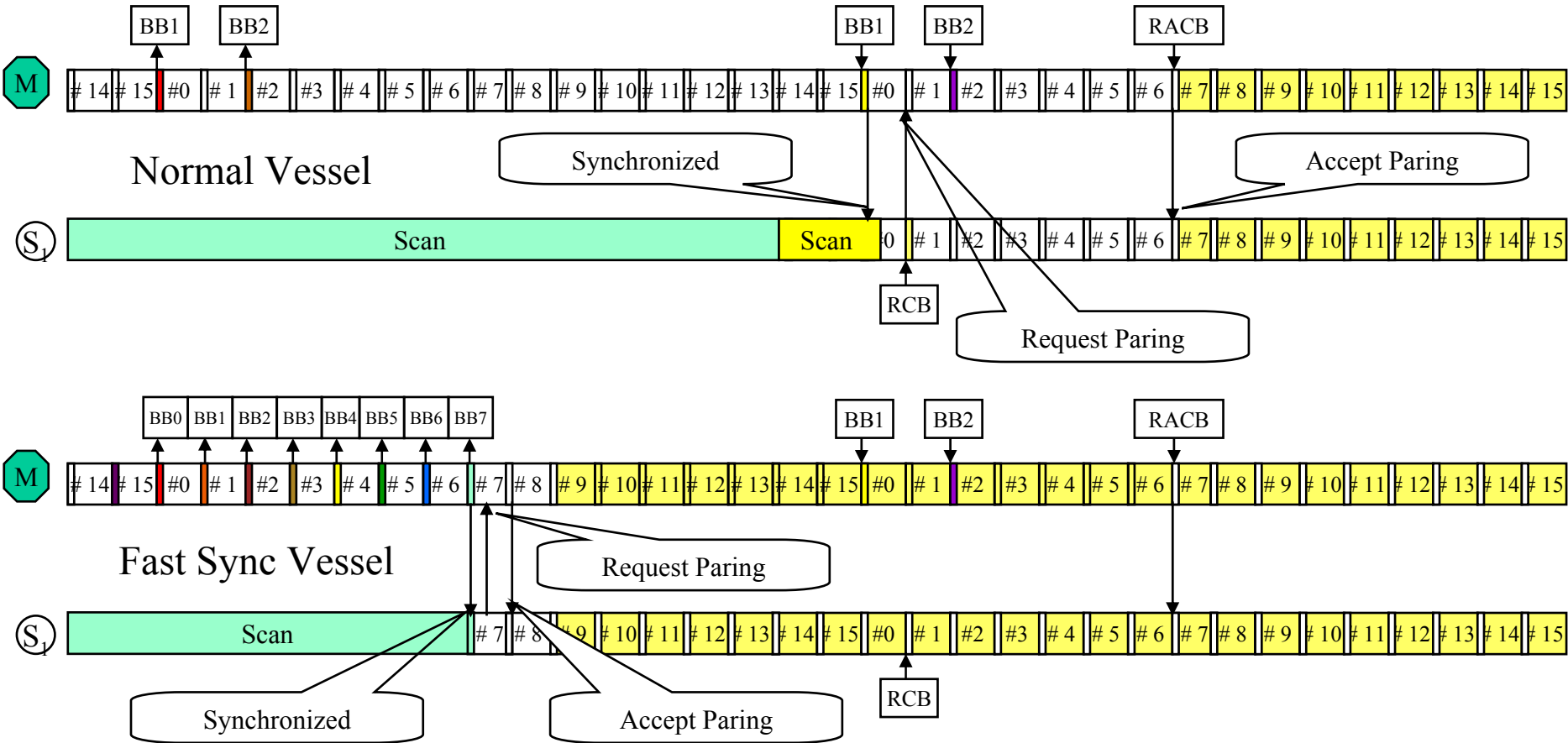

- ❖ Full scan time of normal vessel is 2sec.
- ❖ That of fast sync vessel is only 256msec

Protocol Topologies - continued

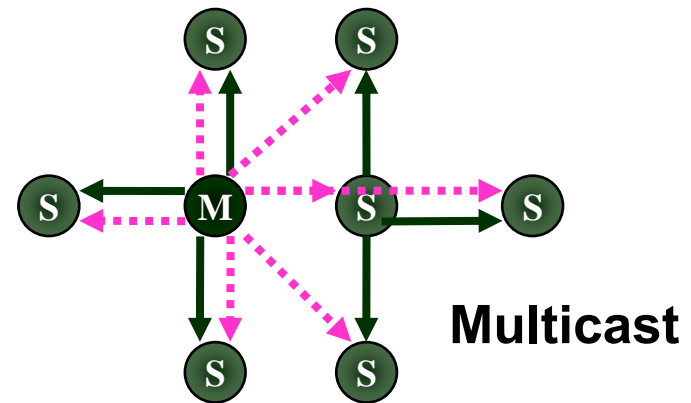
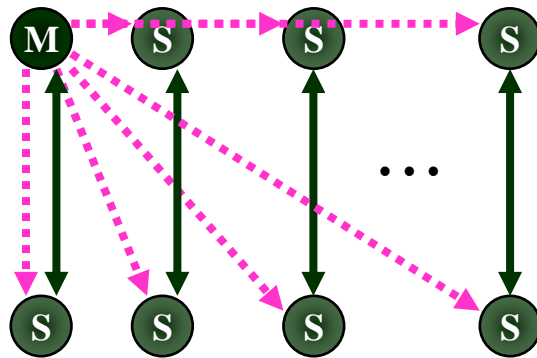
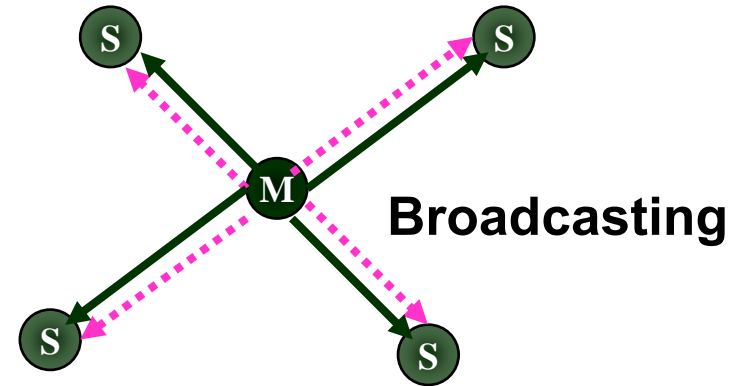
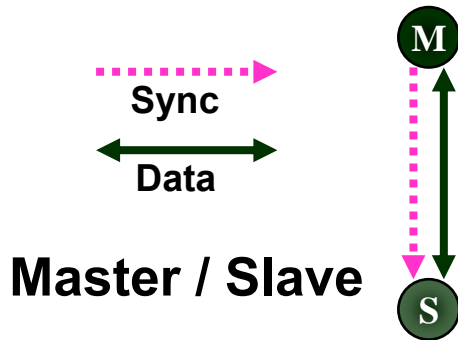

Protocol Topologies

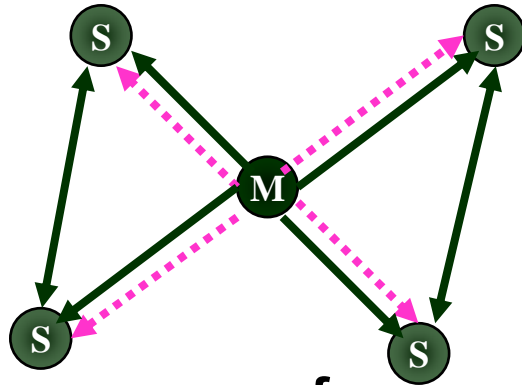

Convergence of Broadcasting & Communication

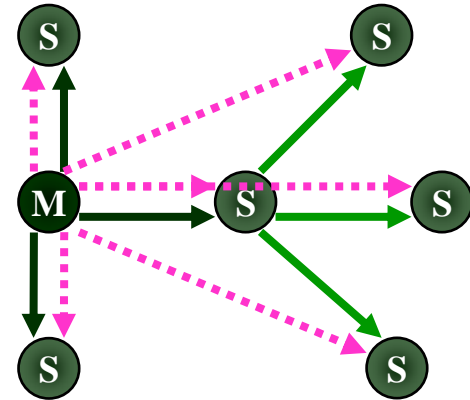

Broadcast Relay with Single Master

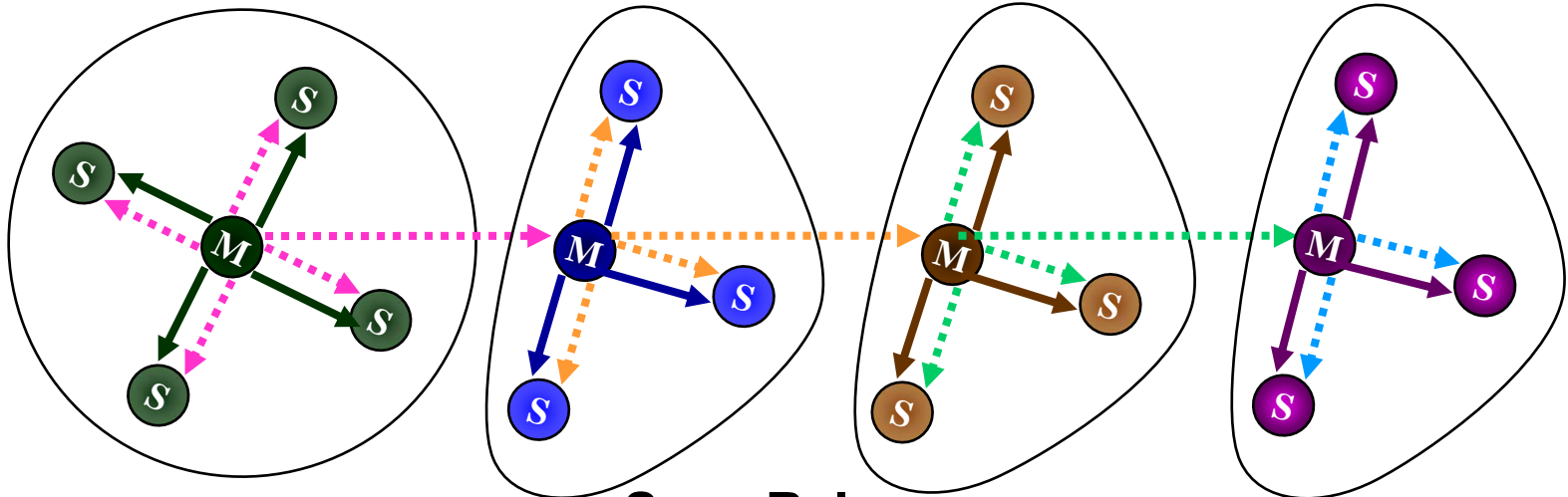

Sync Relay

Additional Considerations for WBAN

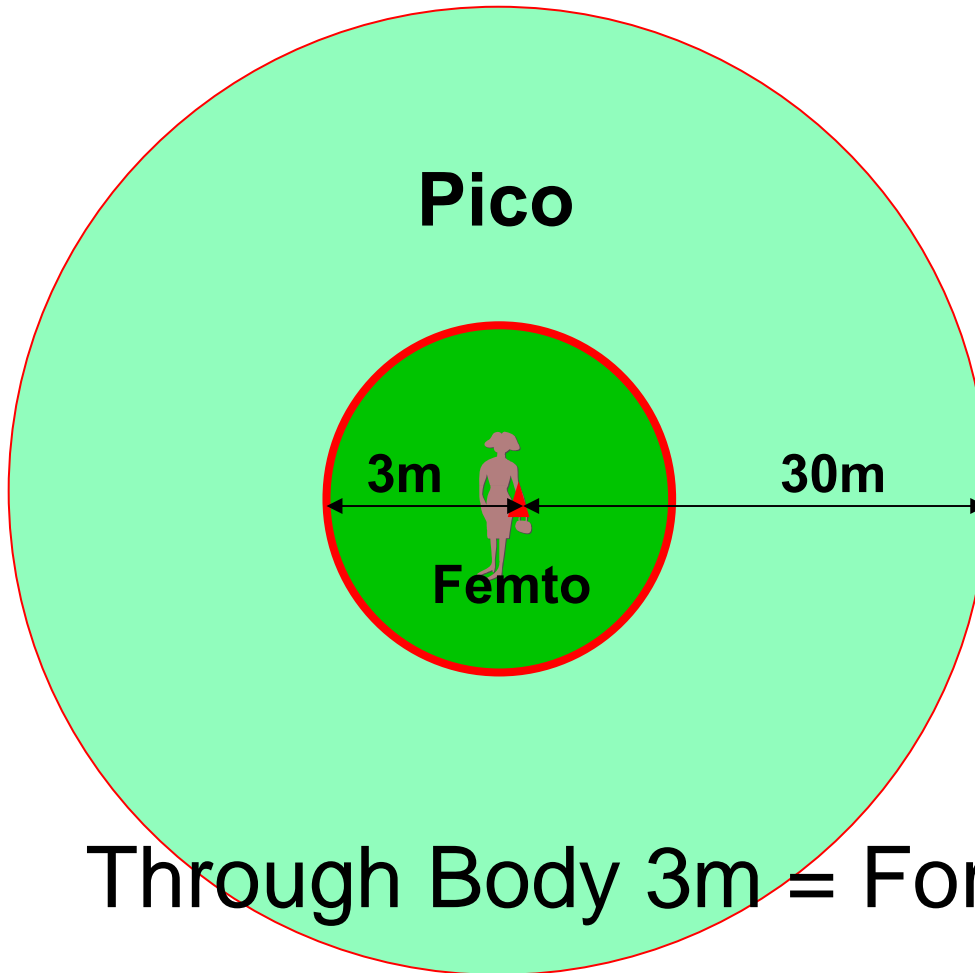

- Open PHY Interface
- Power Control
- Smooth Sliding Sync
- Role Exchange
- QoS Check
- Sounding
- Emergency Flooding
- Roaming / Hand-over
- Sensor Mesh Relay

Through Body 3m = Forward Body 30m

Conclusion

- ❖ **PicoCast protocol is submitted as a single MAC for multiple PHYs.**
 - Container concept to reject mutual interference and converge various services
 - Multi preamble to enhance synchronization probability & for special purposes
 - Hierarchical sync & code structure for scalable & self organizing system
 - Common channel signaling based on vessel structure for various service
 - **Welcome Multiple preamble usage for special purpose like medical application**
- ❖ **Suggested MAC can be used for 5G mobile communication, too.**
 - WBAN body master & mobile femto-cell have almost same structure
 - In the future, the cell size of 5G will become femto-cell because of capacity
 - User oriented broadcasting and communication convergence is possible
 - White space device requirements would be satisfied with PicoCast protocol
- ❖ **System evaluation tool and S/W driver can be supplied to PHY partners.**
 - Technical sheet of PHY interface can be supplied to whom want to be partner
 - Evaluation board to test interoperability can be supplied as project base
 - Stable & reliable S/W library for single PHY is possible now
 - S/W library for multiple PHYs will be open within the end of this year

Thank You !!!

Q & A

Seung Moon Ryu

Vice President, PicoCast Forum

(www.picocast.org)

CEO, Casuh Corp. (www.casuh.com)

retaw@picocast.org

+82-31-709-5577