

Project: IEEE P802.15 Working Group for Wireless Personal Area Networks (WPANs)

Submission Title: [Resolutions to Comments on CMS and Preambles]

Date Submitted: [September 2008]

Source: [R. Funada, M.A Rahman, C.S Sum, T. Baykas, J. Wang, M. Umehira, H. Harada, S. Kato(1), I. Lakkis(2)]

Company [(1) NICT, (2)Tensorcom]

Address []

Re: []

Abstract: [Resolutions to Comments on CMS and Preambles]

Purpose: [This document provides proposed resolution fro some comments on 802.15.3c/DF00]

Notice: This document has been prepared to assist the IEEE P802.15. It is offered as a basis for discussion and is not binding on the contributing individual(s) or organization(s). The material in this document is subject to change in form and content after further study. The contributor(s) reserve(s) the right to add, amend or withdraw material contained herein.

Release: The contributor acknowledges and accepts that this contribution becomes the property of IEEE and may be made publicly available by P802.15.

- **Comment 447, 463: Improve Common Mode Signaling Performance**
- **Resolution:**
- **Payload and Header: 3dB improvement**
 - By changing Spreading length from 32 to 64
 - Use a64 or b64 based on LFSR with known initial state at both transmit and receive.
- **Long Preamble: 4.7 dB improvement**
 - SYNC: Change from 32 repetitions of s128 to 64 repetitions of s128
 - SFD: Change from 1+3 repetitions by s128 to 8 repetitions [-1 -1 -1 1 -1 1 -1 -1] spread by s128
 - CES : Change from a_{pre} a256(8 times) a_{pos} b_{pre} b256(8 times) b_{pos}
- **CCA: 6 microseconds**

- **Link Budget with improved CM:**
- **Assumptions**
 - NF = 8 dB,
 - GTx = GRx = 3dB, (antenna gains)
 - Propagation Loss Index = 2.5
 - Shadowing margin= 5dB
 - Implementation loss = 1.5dB
- **Results**
 - Payload Range with Spreading Factor 64 and concatenated RS(255,239),Hamming(12,8) code is 10 m
 - Link Margin = 1.3 dB

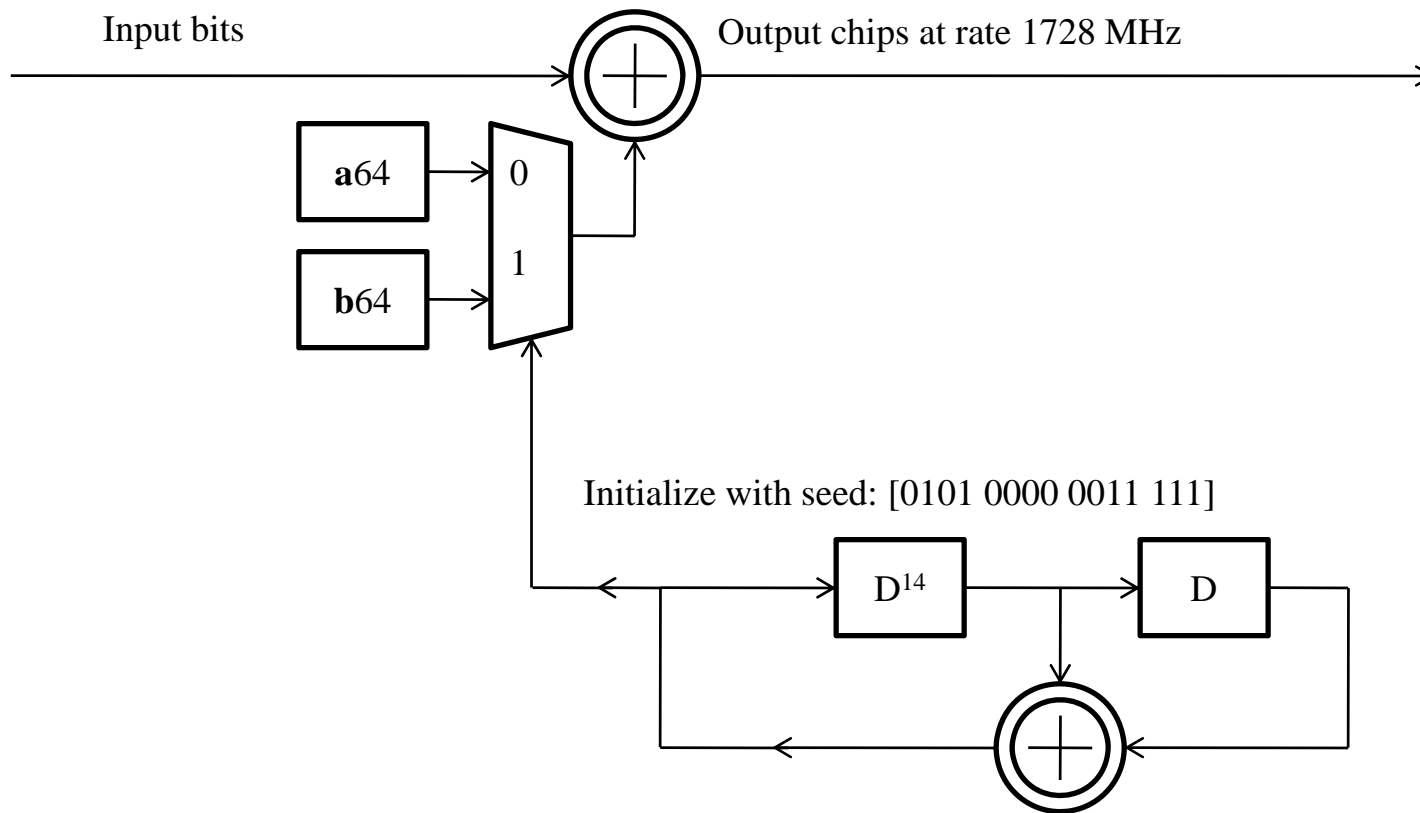

- **Comment 411, 619, 623:**

CID	Comment	Suggested Remedy
619	How are the "preamble type (PT)" bits to be used? If the frame is not decoded properly at the receiver, this means that some number of subsequent frames may be expected to also not be decoded correctly, since the receiver may not be expecting the preamble type. Is there a need for acknowledgement feedback?	Please clarify how the PT bits are to be used or remove the feature.
623	The use of Preamble type must be clarified. What happens if a receiver fails to decode preamble type from frame N? Are frames N+1..N+K, K = ? lost? Is an ACK mechanism assumed.	Please clarify or eliminate this "feature".
411	The use of preamble type bits needs to be clarified. In order for this to work in an interoperable manner, the transmitting station needs to understand what type of preamble the receiving station is expecting. The transmitting station can only change the preamble type after a frame has been ack'd. This can get very complicated, especially when multiple receiving stations and a block ack mechanism is used.	Justify the need for this feature and either simplify or explain it detail how it will be implemented.

- **Resolution:** Accept
 - a) Use long preamble for common mode only.
In a CTA, use either default preamble or short preamble.
 - b) The first frame/ACK shall use the default preamble, while the remaining frames shall use either the default preamble or the short preamble.
 - c) The preamble chosen for the 2nd frame shall be maintained for the rest of the CTA.
 - d) Keep preamble type bit. PT bits will be used in low latency mode in very reliable channel, to enable switching from one preamble to another to improve efficiency.

Comments 340, 346, 607, 608, 621 Preamble Performance

- **Resolution:**
- **CMS**
 - Long Preamble: Same Resolution to CID 467
- **Data Frames and Beamforming**

- **Medium Preamble:**

SYNC = 32 repetitions of a128

SFD = [-1 +1 +1 -1] spread by a128 (low rate header)

= [-1 -1 +1 +1] spread by a128 (high rate header)

CES = [a_{pre} a256, a256 a_{pos} b_{pre} b256, b256 b_{pos}]

- **Short preamble**

SYNC = 8 repetitions of a128

SFD = [-1 +1 -1 +1] spread by a128 (only low rate header)

CES = a_{pre} a128(1 repetition) a_{pos} b_{pre} b128(1 repetition) b_{pos}

Comments 413

- How does a receiving station know which SYNC sequence to expect? Is it expected to receive frames using any of these?
- **Resolution:**
- Accept in principle: Multiple spreading codes are eliminated from the draft. Resolve as indicated in CID 415.