

**Project: IEEE P802.15 Working Group for Wireless Personal Area Networks (WPANs)**

**Submission Title:** [DS-UWB Proposal Update]

**Date Submitted:** [September 13, 2004]

**Source:** [Ryuji Kohno, Kenichi Takizawa, Yuko Rikuta, Iwao Nishiyama] Company [ National Institute of Information and Telecommunication Technology(NICT) ]Connector's Address [3-4, Hikarino-oka, Yokosuka, 239-0847, Japan]

Voice:[+81-468-47-5101], FAX: [+81-468-47-5431],

E-Mail:[kohno@nict.go.jp, takizawa@nict.go.jp, rikuta@nict.go.jp, nishiyama@nict.go.jp ]

**Re:** []

**Abstract:** [Feasibility of Spectral Shaping]

This document has been prepared for explaining feasibility of analog implementation of spectral shaping of transmitted UWB signals in order to show some examples for avoiding interference to coexisting systems.

**Purpose:** [Provide technical information to the TG3a voters regarding DS-UWB (Merger #2) Proposal]

**Notice:** This document has been prepared to assist the IEEE P802.15. It is offered as a basis for discussion and is not binding on the contributing individual(s) or organization(s). The material in this document is subject to change in form and content after further study. The contributor(s) reserve(s) the right to add, amend or withdraw material contained herein.

**Release:** The contributor acknowledges and accepts that this contribution becomes the property of IEEE and may be made publicly available by P802.15.

# ***Feasible Implementation of Soft Spectral Shaping***

- 1. Notch generation by using a simple analog delay line: Analog type of SSA**
- 2. Notch generation by using a spreading code**
- 3. Notch generation by using a multiple frequency antenna**

# 1. Basic philosophy of Soft-Spectrum Adaptation

- Design a proper pulse waveform with higher *frequency efficiency* corresponding to any spectral mask
- Adjust transmitted signal's spectrum with *flexibility*, so as to minimize interference to/from coexisting systems
- Employ *optimized* pulse wavelets to achieve higher system performance

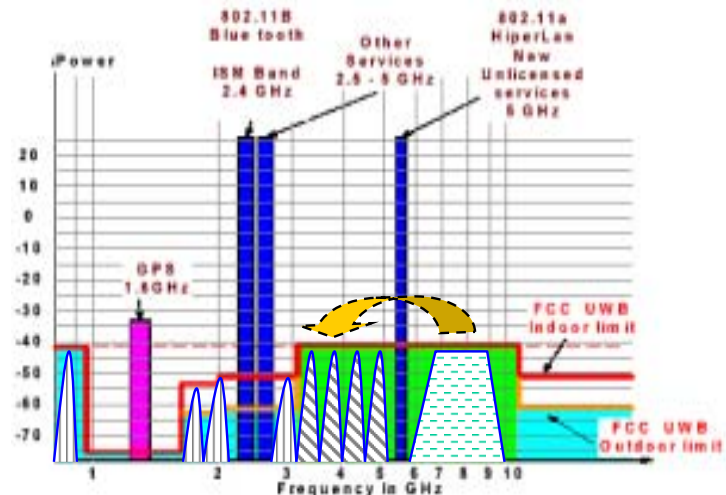
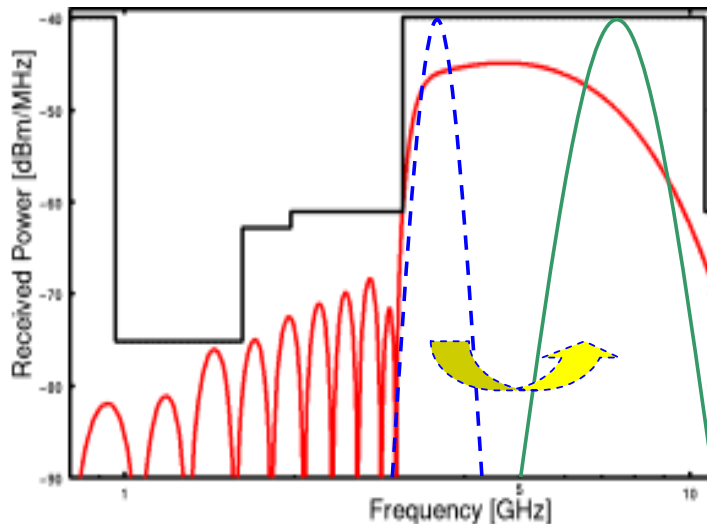

## Basic Formulation

$$f(t) = \sum_{k=1}^N f_k(t) \leftarrow \text{Synthesize pulse waveform}$$

In case of multiband: Kernel function is Sinusoidal

$$f_k(t) = \cos\left[2\pi\left(f_L + \frac{(1+2k)B}{2N}\right)t\right] \times \frac{\sin(B\pi t)}{N\pi t}$$

*B: bandwidth [f<sub>H</sub> ~ f<sub>L</sub>]*

## Example of Pulse Generator

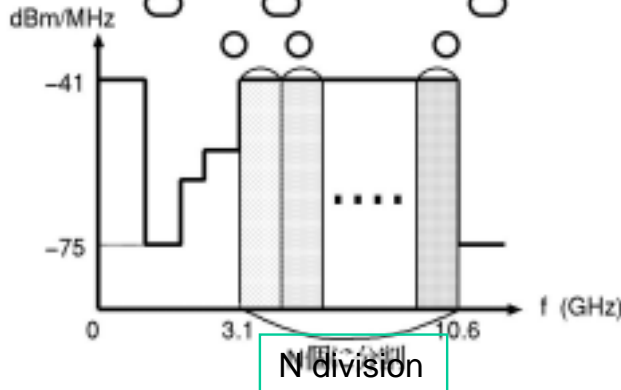
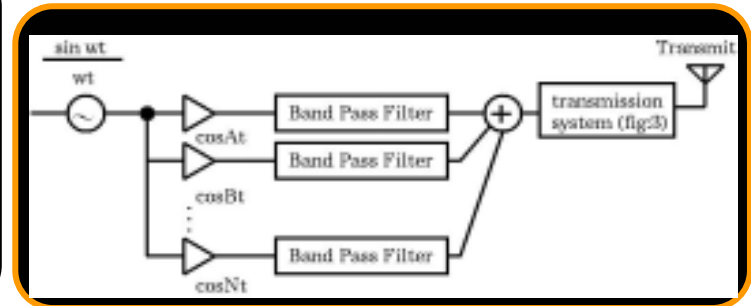

Feasible Solution: Pulse design satisfying Spectrum Mask

- Divide (spread-and-shrink) the whole bandwidth into several sub-bands → Soft Spectrum (spectrum matching)
- Pulse synthesized by several pulses which have different spectra → Soft Spectrum, M-ary signaling

# SSA-UWB with flexible band plan

Single-band

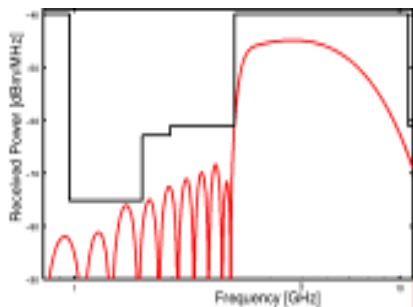

Dual- or Triple-band

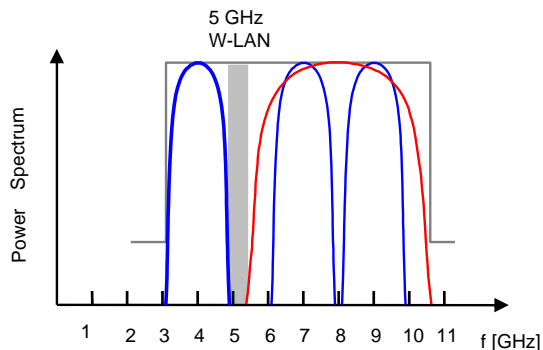

Multi-band

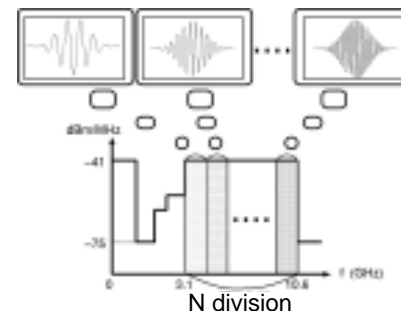

In the future, if the restricting ruggedness of regional spectral mask (e.g. FCC mask) is eased, band allocation can be extended below 3.1 GHz or above 10.6 GHz.

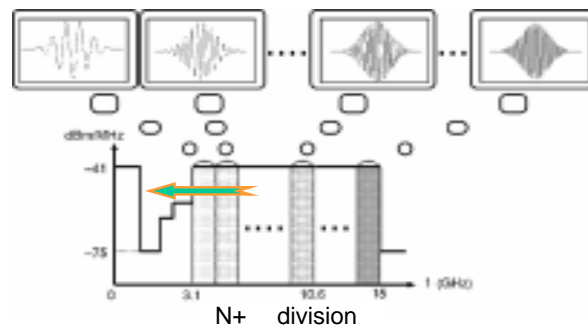
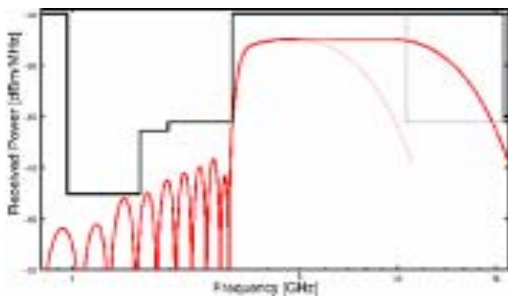

Soft-Spectrum Adaptation (SSA) can correspond freely

# Soft-Spectrum Adaptation(SSA) Classification

## (1) Free-Verse Type of SSA

- A kernel function is **non-sinusoidal**, e.g. **Gaussian**, **Hermitian** pulse etc.
- Single band, **Impulse radio**

## (2) Geometrical Type of SSA

- A kernel function is **sinusoidal** with different frequency.
- **Multiband** with carriers and **Multi-carrier**

## (1) Free-verse Type Soft-Spectrum Adaptation

→ Freely design pulse waveforms by synthesizing pulses, e.g. overlapping and shifting

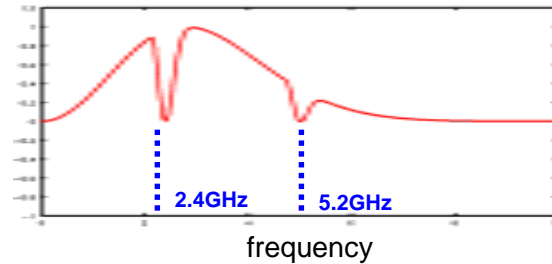
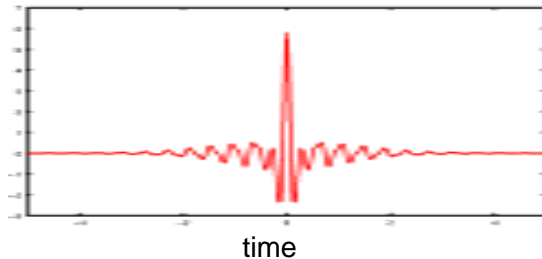

K-3 Free-verse Soft-Spectrum Adaptation pulse  
(Note: band notches clearly happen at 2.4 and 5.2 GHz as well)

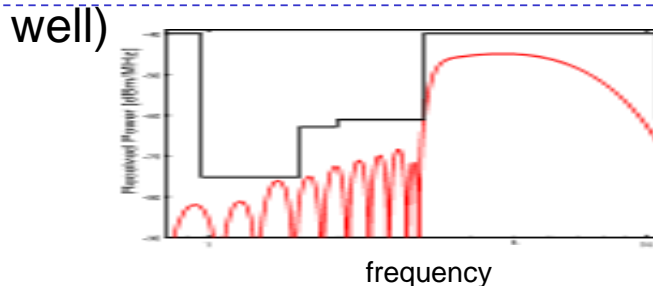
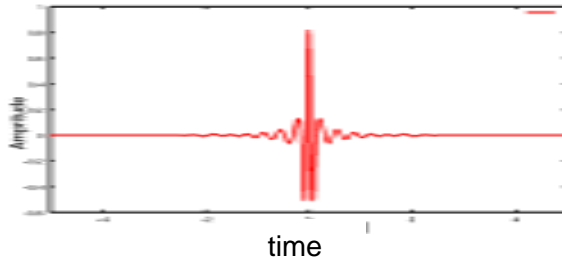

K-4 Free-verse Soft-Spectrum Adaptation pulse  
(Note: pulse waveform has more freedom)

# Japanese Spectral Allocation of Coexisting Systems in 3.1 ~ 10.6GHz (no blank spectrum slot)

3000 MHz – 10000 MHz

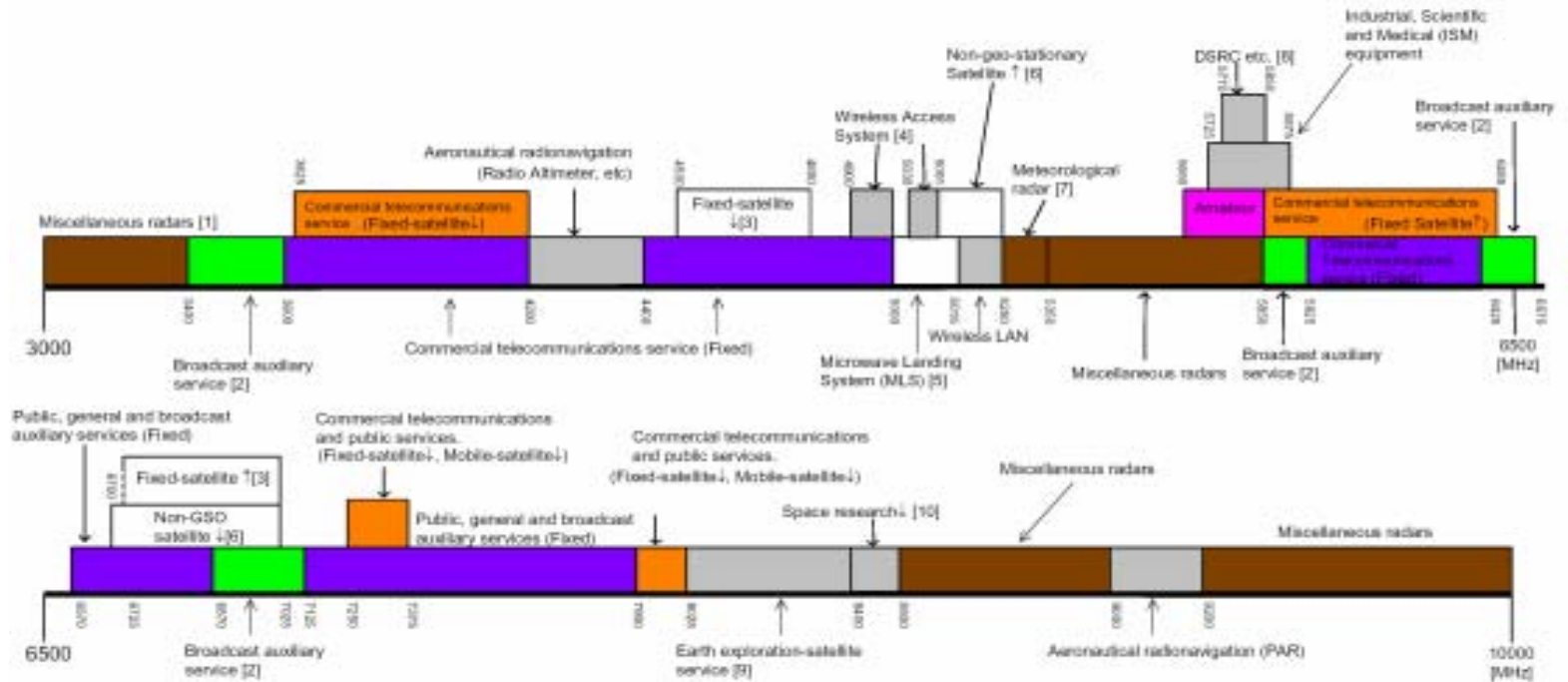

\* Supplementary information on the next page.



# Modified SSA-UWB pulse wavelet with adaptive spectral notches achieving coexistence, flexibility and efficient power transmission

SSA-UWB optimized pulse wavelet generation

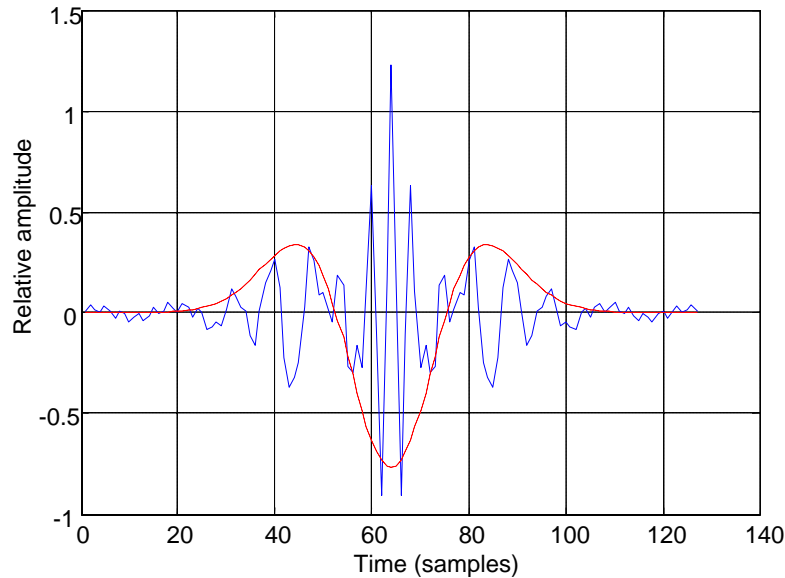

Spectrum characteristics of SSA-UWB optimal pulse wavelet

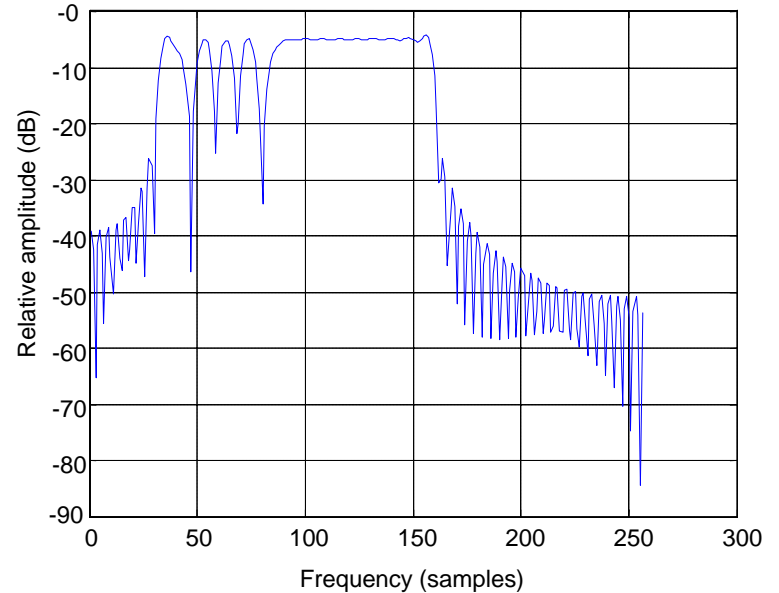

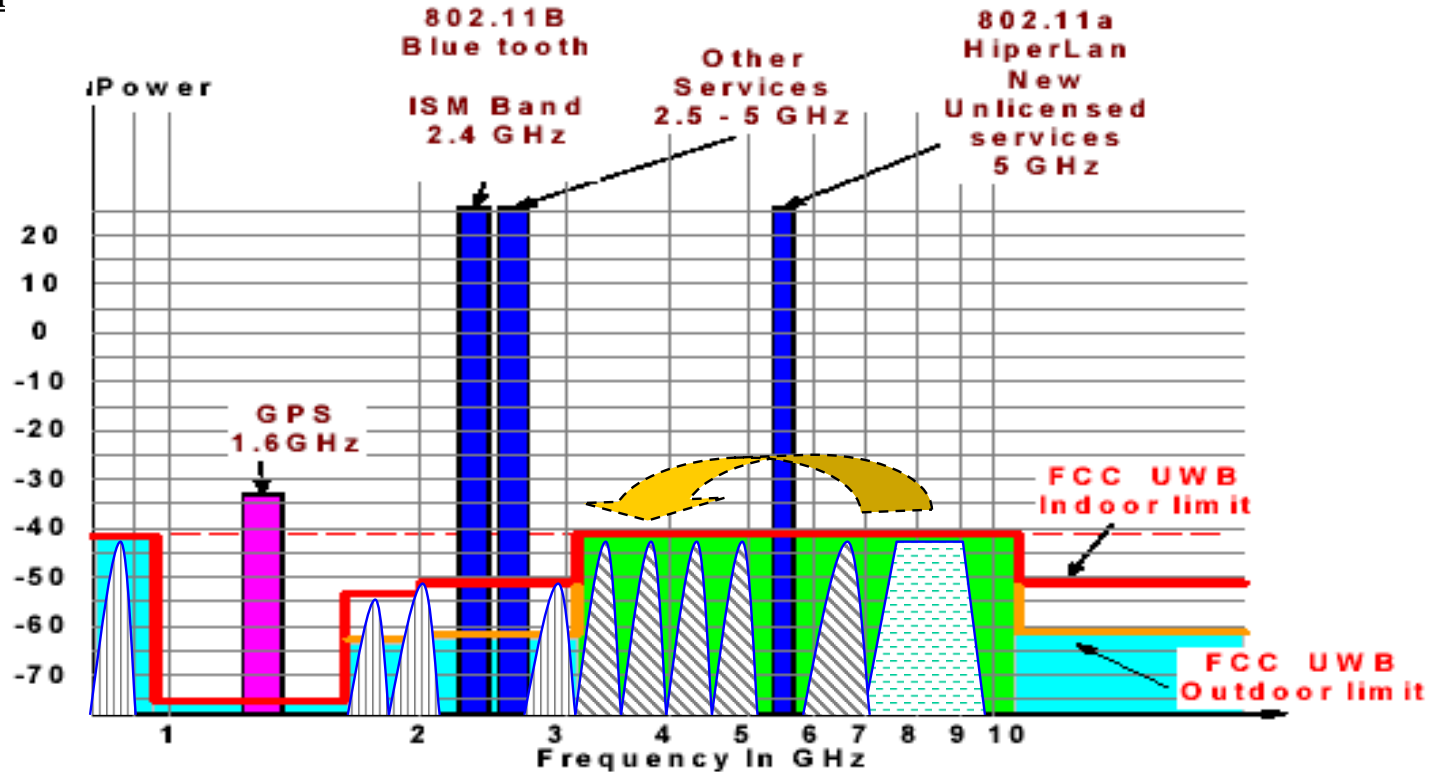

Geometric Soft-Spectrum Adaptation (Spread-and-Shrink) and pulse waveform shaping provide new dimension, frontier, and challenge ( seeing FCC UWB Emission Limit: FCC 02-48, UWB Report & Order)

# Global harmonization and compromise based on SSA-UWB

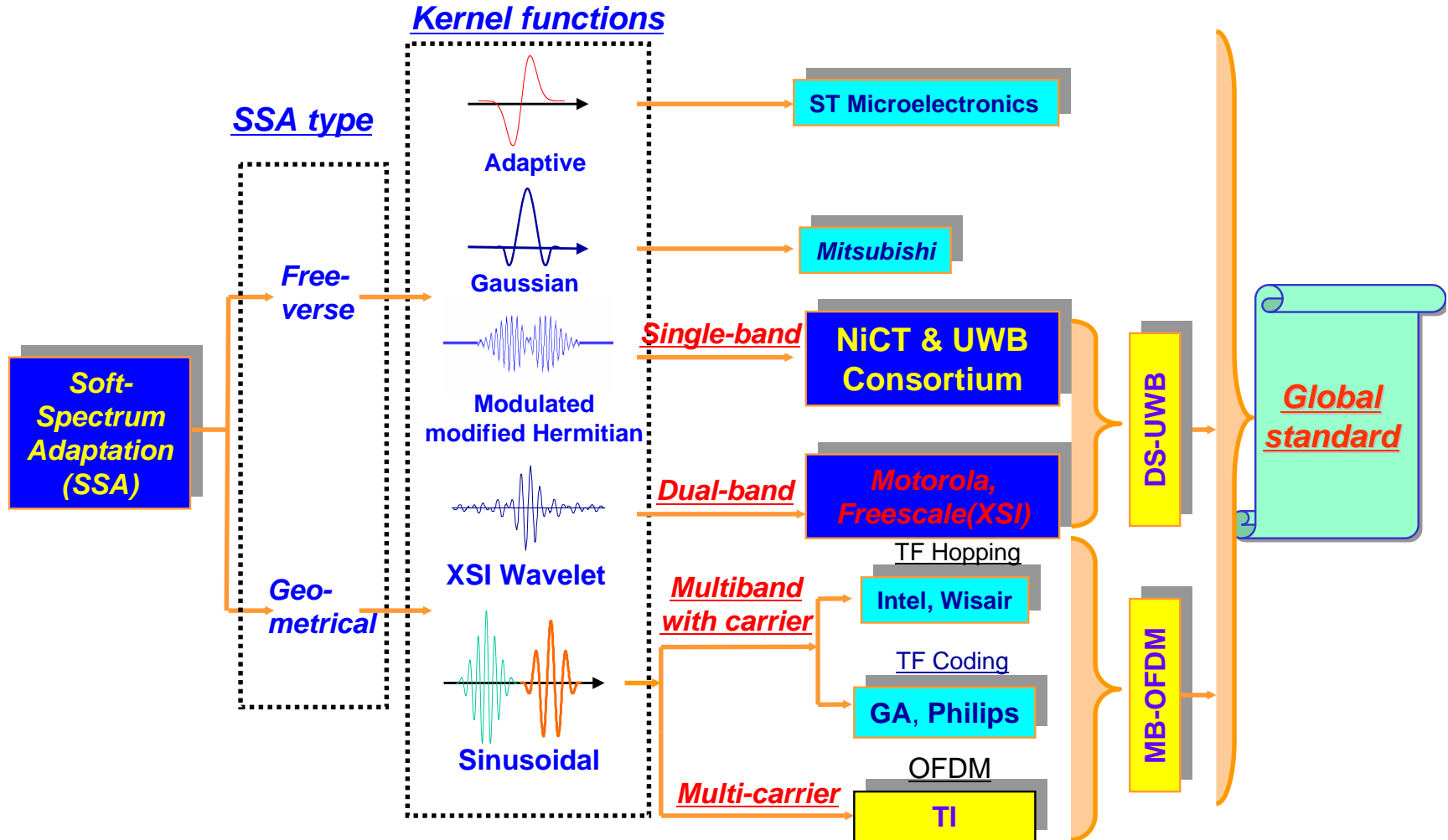

## Summary of Soft-Spectrum Adaptation

- **Global Regulatory Satisfaction: Soft-Spectrum adaptation(SSA)** can satisfy the FCC Spectrum Mask and any Mask adaptively.
- **Interference Avoidance: SSA** can be applied to avoid possible interferences with other existing narrowband wireless systems.
- **Global Harmonization: SSA** is good for harmonization among different UWB systems because **SSA** includes various proposed UWB systems as its special cases.
- **Future Version-up: SSA** is so scalable as to accept future UWB systems with better performance like **Software Defined Radio(SDR)**.

# 1. Notch generation by using a simple analog delay line: Analog type of SSA

## • Example: Just Two taps delay line

The output signal  $x(t)$  is given by

$$x(t) = w_0 p(t) + w_1 p(t - \delta)$$

where  $p(t)$  is a pulse signal, and  $\delta$  is delayed time by a delay line D.

By assuming that coefficients  $w_0$  and  $w_1$  is time-invariant, then its signal in frequency domain is given by

$$X(f) = (w_0 + w_1 e^{j2\pi f \delta}) P(f)$$

Now, we set  $w_0=1$  and  $w_1=a$  ( $a$  is in real value), we obtain

$$X(f) = (1 + a e^{j2\pi f \delta}) P(f) = (1 + a \cos 2\pi f \delta + j \cdot a \sin 2\pi f \delta) P(f)$$

A notch is generated at a frequency  $f_n$  where  $|X(f_n)|^2=0$ , then

$$a^2 + 2a \cos 2\pi f_n \delta + 1 = 0$$

The solutions are given by  $a = -\cos 2\pi f_n \delta \pm \sqrt{-\sin^2 2\pi f_n \delta}$ , however, the coefficient  $a$  can take only real value. Therefore,

$$f_n \delta = m/2 \quad (m=1,2,3,\dots) \quad a = -\cos m\pi$$

As you can see, the coefficient  $a$  takes +1 or -1. It leads simple implementation.

The right figure is an example;  $a$  is set to 1 and  $\delta$  is set at 0.116nsec.

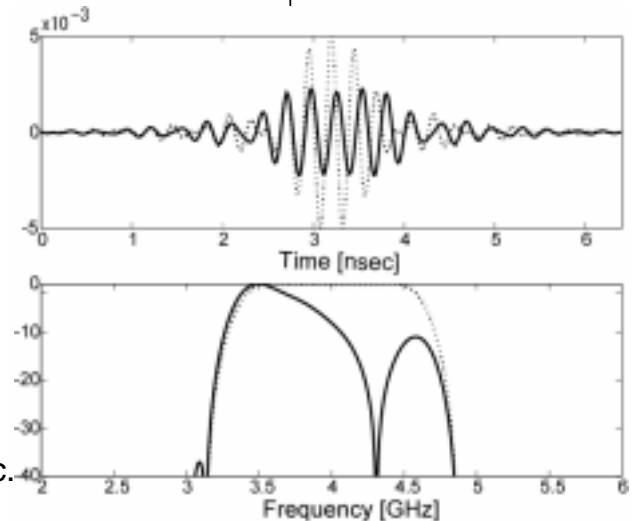
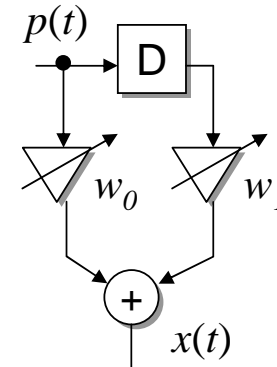

# Notching (Experiments)

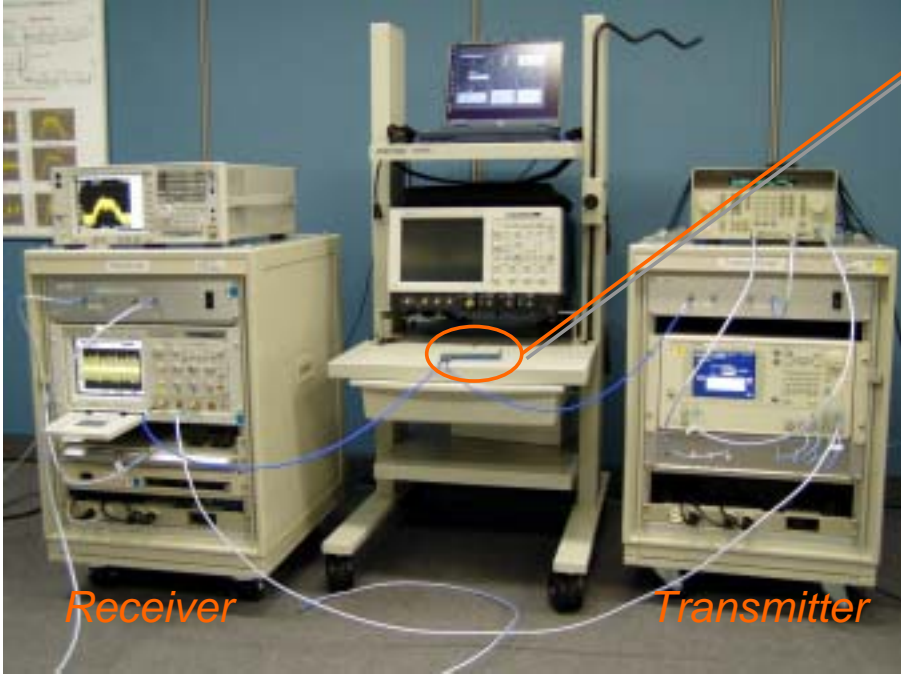

UWB Testbed by NICT

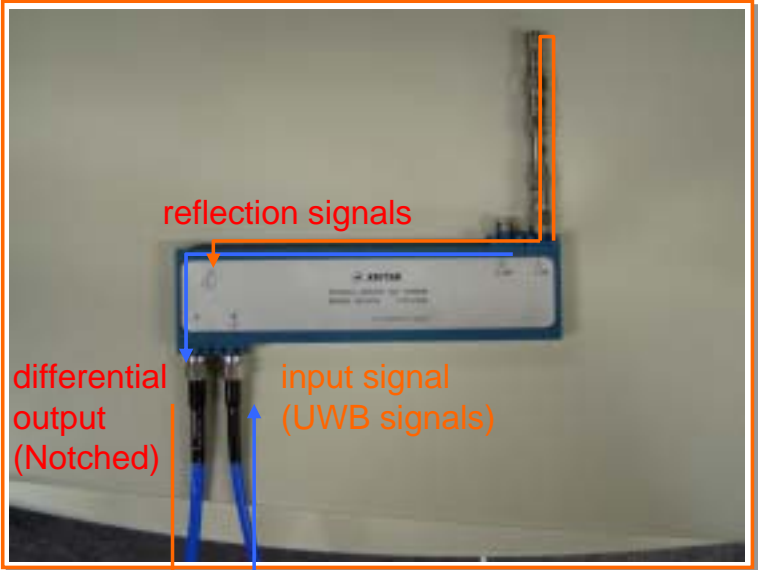

Notch generator (by using 180° Hybrid)

# Experiments

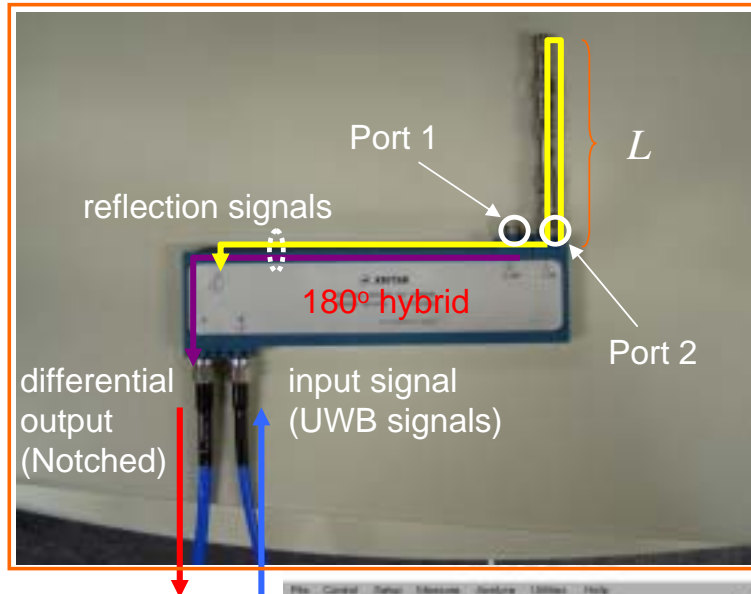

By setting the electric length  $L$  ( $=c\delta=c/f_n; m=2$ ), a notch at arbitrary frequency  $f_n$  is obtainable, in principle.

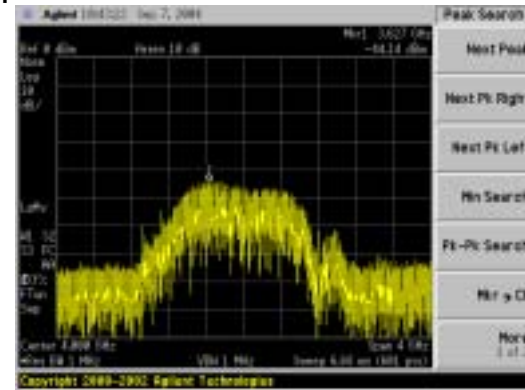

input signal (UWB signals)



reflection signals from Port 1 and 2

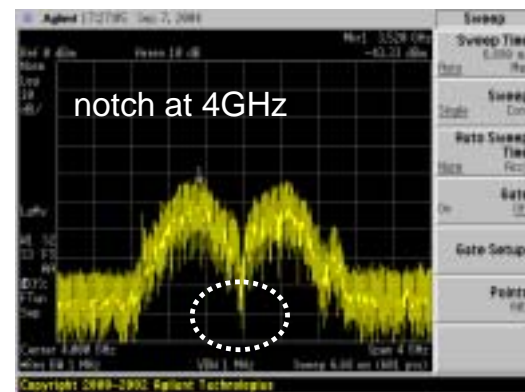

output signal ( $L=3.5\text{cm}$ )



# Other results

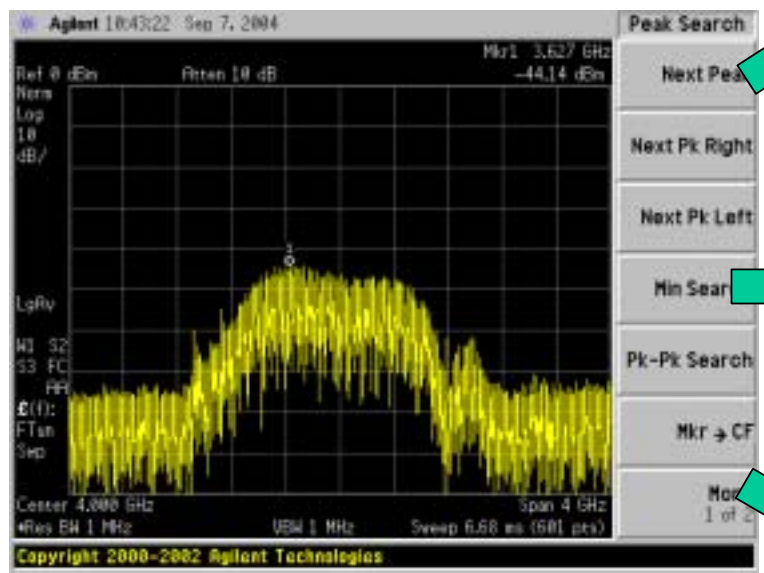

input UWB signal

Different electric length  $L$

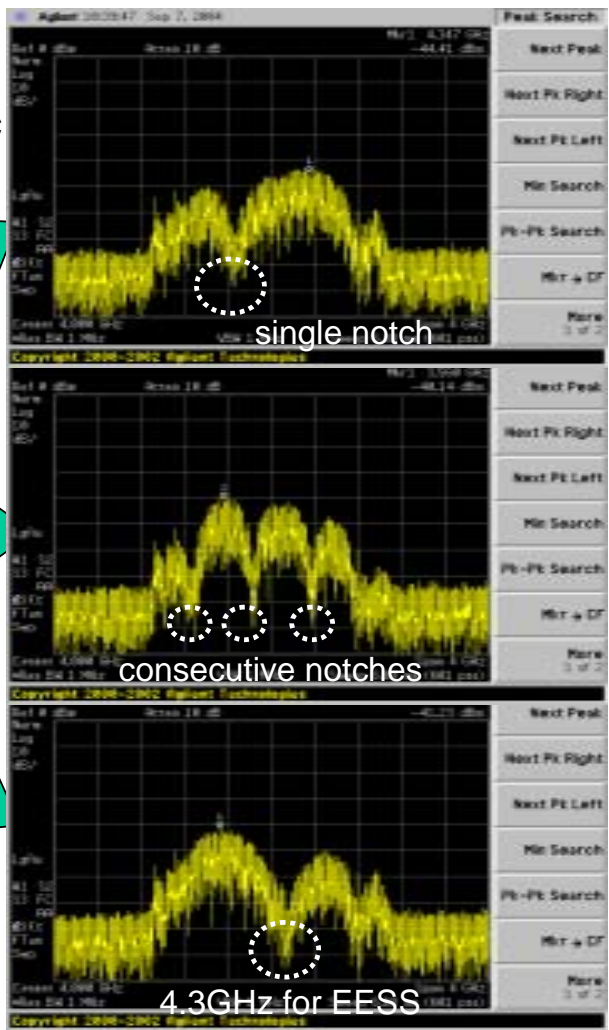
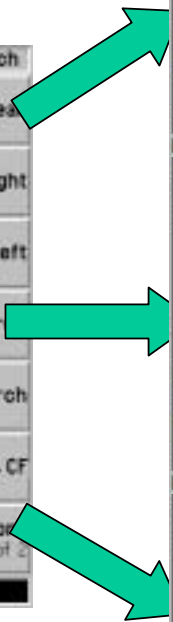



## 2. Notch generation by using a spreading code

- DS-UWB systems

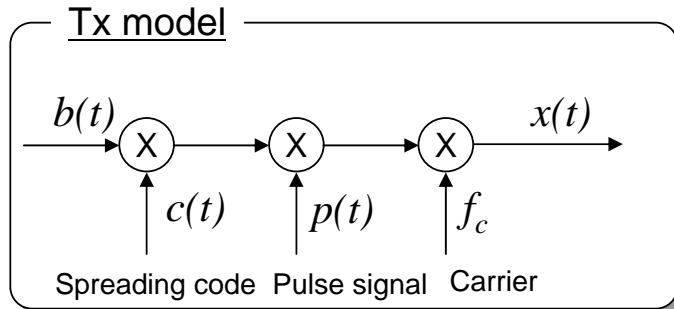

Frequency domain

$$X(f + f_c) = B(f) \otimes C(f) \otimes P(f)$$

Output spectrum is given by convolution

By choosing appropriate spreading code, we can design notch matched with a coexisting system.

Example:  $c(t) = [-1 -1 -1 1 1 -1 1 1]$

Spectrum of a spreading code

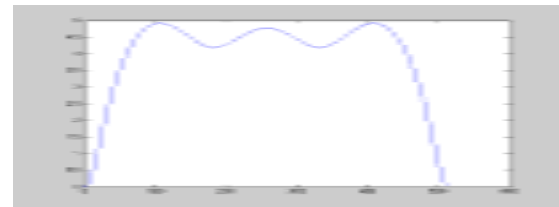

Convolution

$\otimes$

Spectrum of a pulse signal

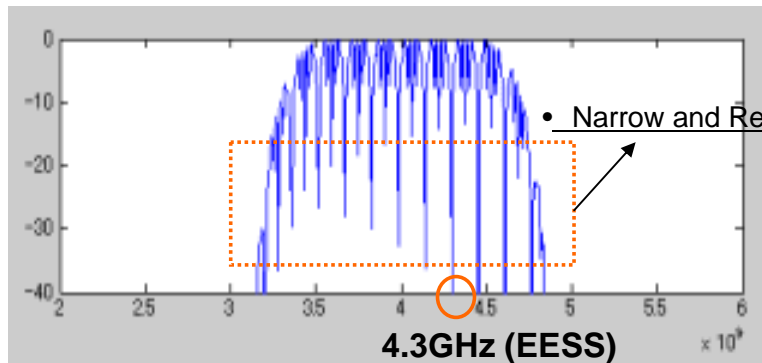
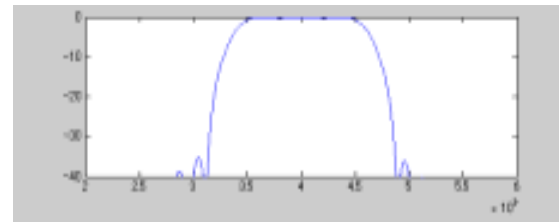

# Notch generation by using a spreading code

- Experimental result by UWB Test bed

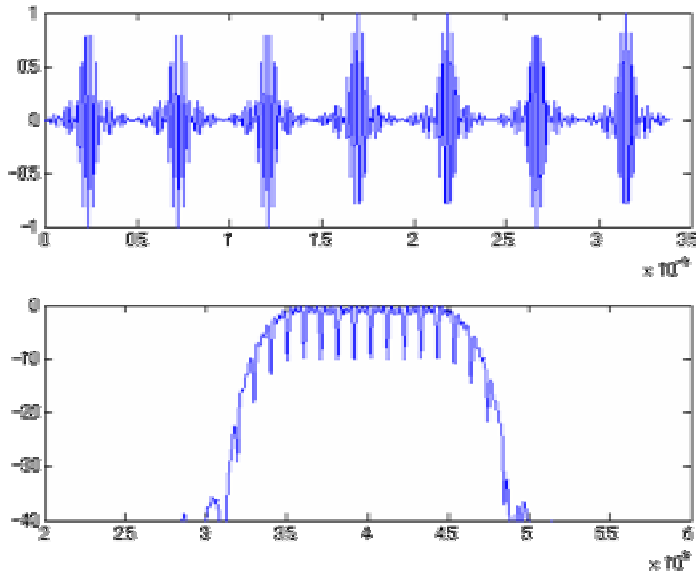

MATLAB results

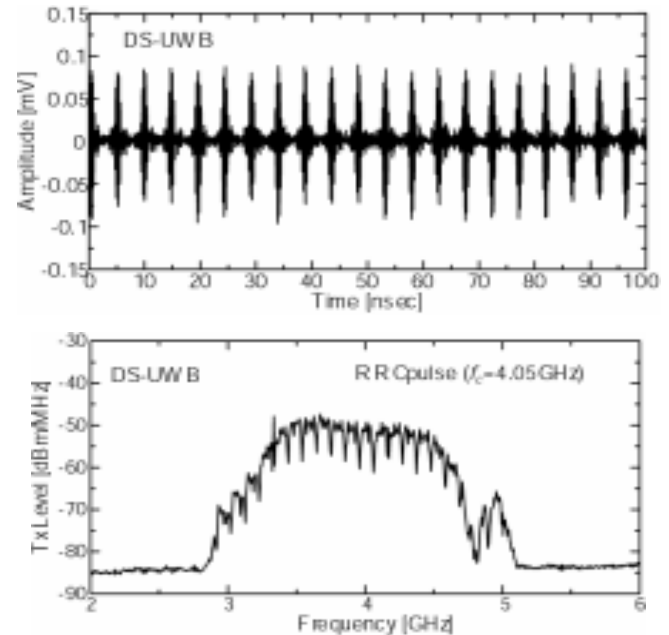

UWB testbed outputs

### 3. Notch generation by using a multiple frequency antenna

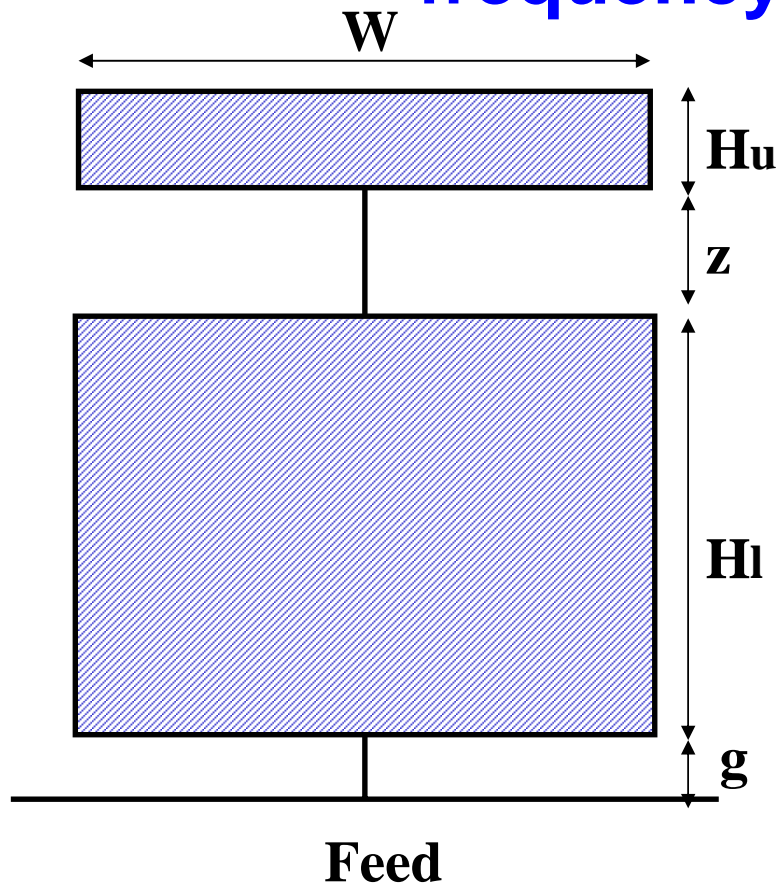

Upper : Rectangle element  
(connected with lower)  
Lower : Rectangle element  
(Planar monopole antenna)

#### FDTD parameter

Cell size:  $D_{x,y}=1\text{mm}$

$D_z=0.5\text{mm}$

Iteration steps : 5000

ABC : PML 8 layer

Input : Gaussian Pulse

# Return Loss Characteristics of Example Antenna With Notch Filtering Capability to Avoid Interference

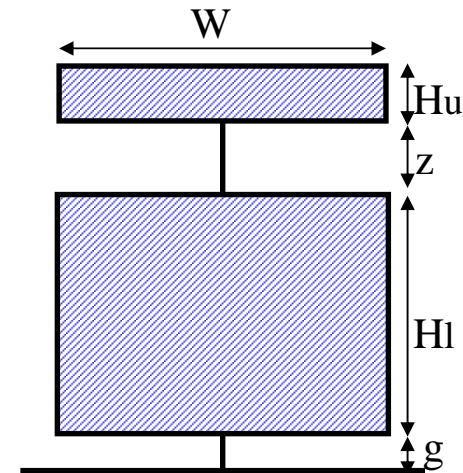
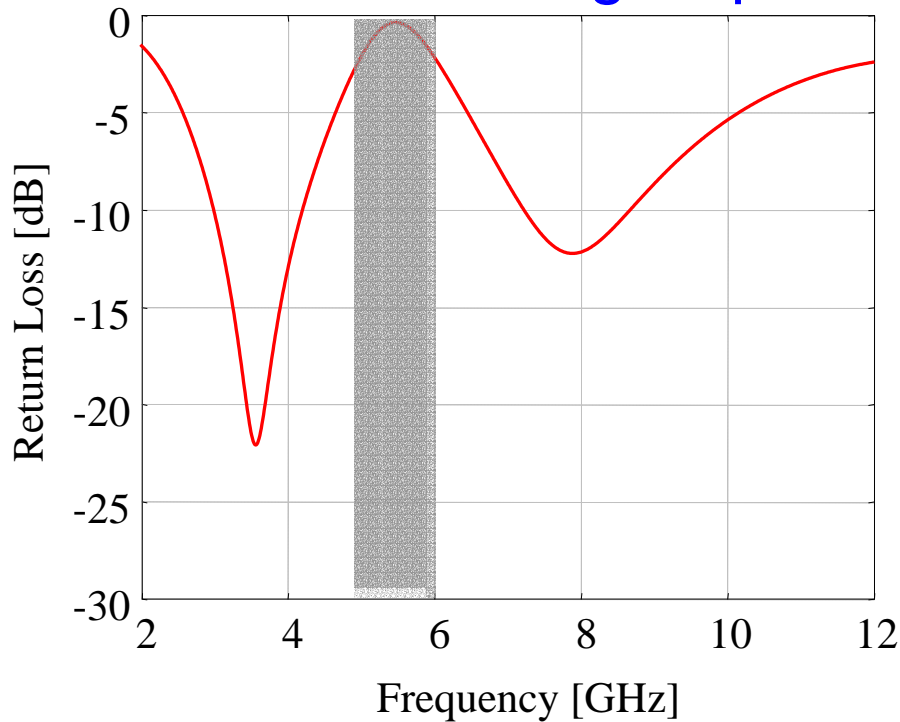

**Wide bandwidth with dual frequency can be achieved.  
Return Loss level is almost 0dB at around 5~6GHz.**

# Example Antenna With Notch Filtering Capability for More Interferences

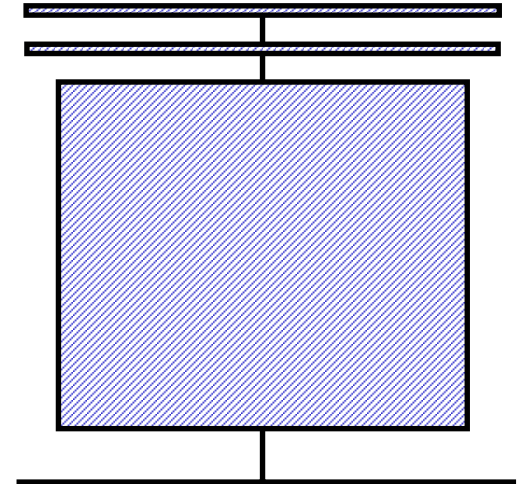
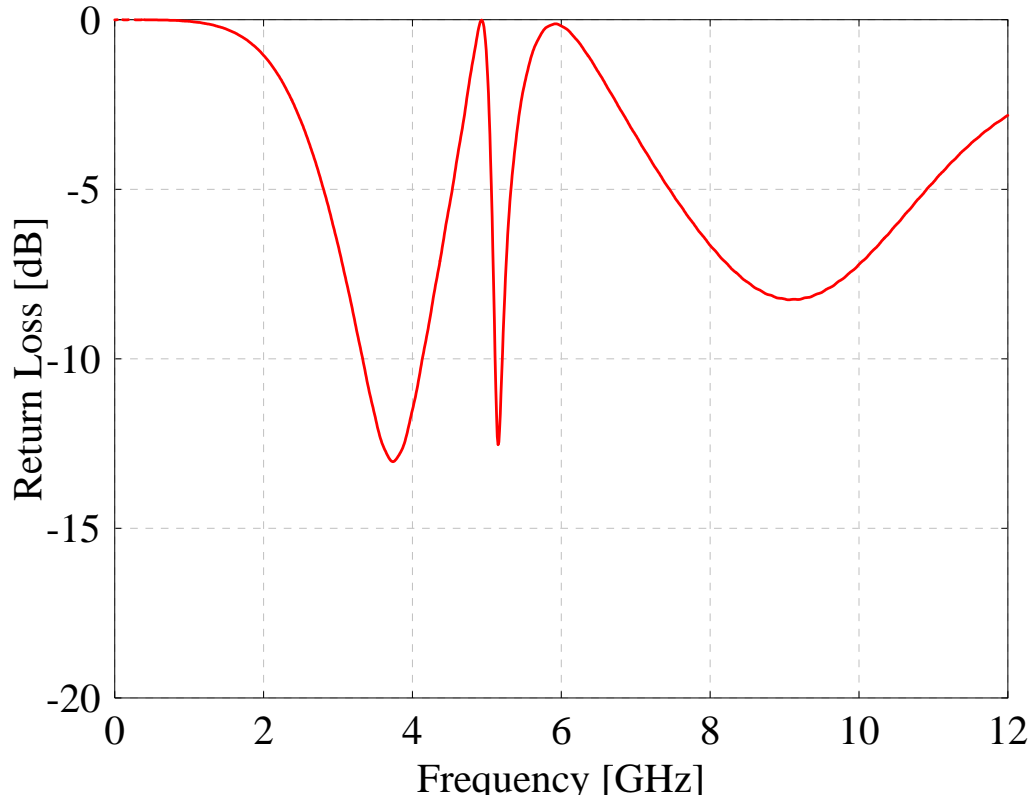

# ***Conclusion on Implementation of Soft Spectral Shaping***

1. To satisfy world wide regulation, a method to avoid interference to coexisting systems is necessary. Since a regulation may be different in each region, a method to avoid interference should be flexible.
2. NICT has presented a Soft Spectrum Adaptation (SSA) and appropriate UWB antennas to satisfy this requirement.
3. SSA is a theoretical optimal solution based on software reconfigurable radio(SDR) concept for this purpose.
4. There are many ways to carry out SSA by digital and analog implementation. This document shows some feasible examples of a way to implement Analog Type of SSA.

**(Approach 1): Notch generation by using a simple analog delay line:**

**(Approach 2): Notch generation by using a spreading code**

**(Approach 3): Notch generation by using a multiple frequency antenna**