

Nendica Study Item Report (Forwarding of Fieldbus CPF 12 on 802.1 Bridges)

2023-4-27

Huajie Bao (Huawei, baohuajie@huawei.com)
Kaiyun Qin (BAOSIGHT)

Introduction

- This slides as informal report are the result of the Study Item “Forwarding of Fieldbus CPF 12 on 802.1 Bridges” within the IEEE 802 “Network Enhancements for the Next Decade” Industry Connections Activity known as Nendica. Usually, the fieldbus type 12 known as EtherCAT could be deployed in Open Mode or Direct Mode, that is an EtherCAT Main Device and a group of Subordinate Devices are connected by a bridged LAN or directly. Both of the two modes still keep the isolation paradigm for such a group of Subordinate Devices which are deployed in the separated network. The separated network is dedicated to the EtherCAT Subordinate devices, and satisfies the requirements of EtherCAT applications. This Study Item tries to deploy 802.1 Bridges into such separated network according to the requests of a use case, studies the impact of determinism and high reliability, and analyzes the possible optimizations initially.
- After the fundamental introduction of EtherCAT, this slides lead to the use case directly, that is a scenario of production expansion trying to use the existing 802.1 Bridges to connect the new expanded EtherCAT Subordinate devices and the existing Ethernet stations nearby, so the 802.1 Bridges have to forward the EtherCAT frames (from Subordinate Devices) and Ethernet frames (from general Ethernet Stations) simultaneously. Then, this slides initially analyze the basic forwarding functionalities and QoS assurance scenarios including determinism & high reliability for EtherCAT frames. According to the QoS assurance scenarios, this slides initially analyze the existing technologies and provide some optimization directions.
- Finally, this slides of informal report provide possible recommendation to initiate a Work Item for further analysis.

* EtherCAT is a registered trade name of Beckhoff Automation. This information is given for convenience of reader in this informal report. Use of trade name EtherCAT requires permission of the trade name holder.

Some Explanations for the Convenience of Readers

- Generally, the terms mentioned in this slides comply with the definition of 802.1Q and EtherCAT specifications. In order to avoid confusion or misunderstanding, the following points are explained.
 - ❑ **EtherCAT MDevice:** means the EtherCAT Main Device, it's a EtherCAT PLC or controller and includes only one MDevice instance in this slides generally unless explicit notes.
 - ❑ **EtherCAT SubDevice:** means the EtherCAT Subordinate Device, it's controlled by the EtherCAT MDevice.
 - ❑ **EtherCAT frame:** the frame sent by EtherCAT MDevice and forwarded by EtherCAT SubDevice or 802.1 Bridges, and the EtherType of the frame equals 0x88a4.
 - ❑ **Ethernet frame:** the frame sent by general Ethernet Stations in this slides, and the EtherType of the frame doesn't equal 0x88a4.
 - ❑ **EtherCAT topological forwarding mode:** the 802.1 Bridge receives the EtherCAT frames from specific ingress port, and forwards the EtherCAT frames to specific egress port according to specific configuration regardless of MAC address of the EtherCAT frames.
 - ❑ **MAC address forwarding mode:** the 802.1 Bridge forwards the frames to the specific port according the destination MAC address of the frame and the MAC address table which is mapping the MAC address to the port.

Contents

1. Fundamental introduction of EtherCAT
2. Summary requirements according to industrial scenarios
3. Potential benefits
4. Summary of initial analysis
5. Impact & optimization of evolving technologies
6. Possible recommendation to initiate a work item

EtherCAT Logical-Ring Forwarding

The Type 12 fieldbus in IEC 61158-3/4/5/6-12 is also known as EtherCAT. An EtherCAT network can be understood as a railway network where EtherCAT SubDevices are treated as stations, data are treated as passengers, and EtherCAT frames are treated as trains. While the EtherCAT frames move through the SubDevices, the SubDevices can off-load and re-load data into EtherCAT frames.

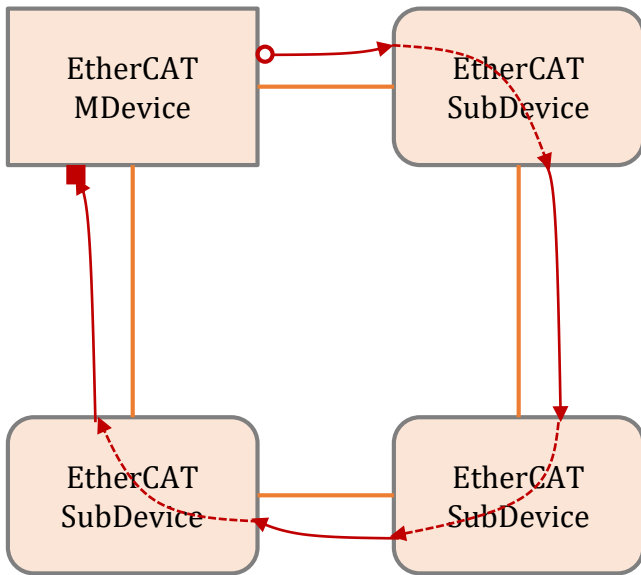

(a)

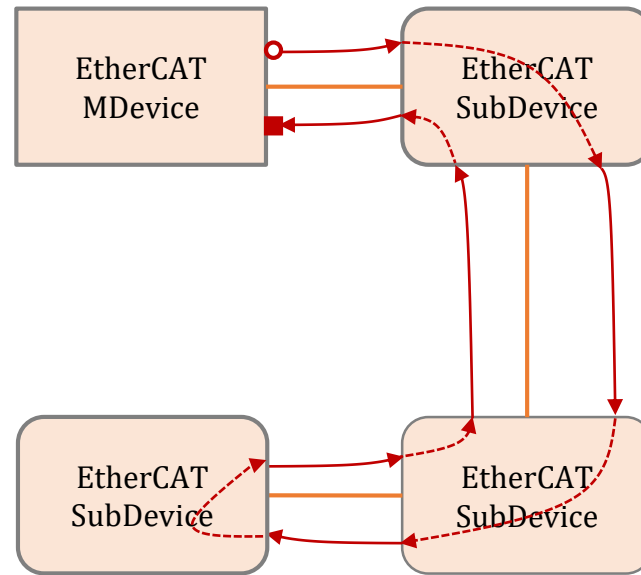

(b)

- EtherCAT frame MAC & PHY follow Ethernet specs
 - ▣ with distinct EtherType
- Frame originates at EtherCAT MDevice, passes each SubDevice (which may modify it) and is returned to MDevice
- Logical topology is a ring
 - a) physical ring topology
 - b) physical line topology
 - ✓ Single-port SubDevice forwards frame back to sender

EtherCAT Junction

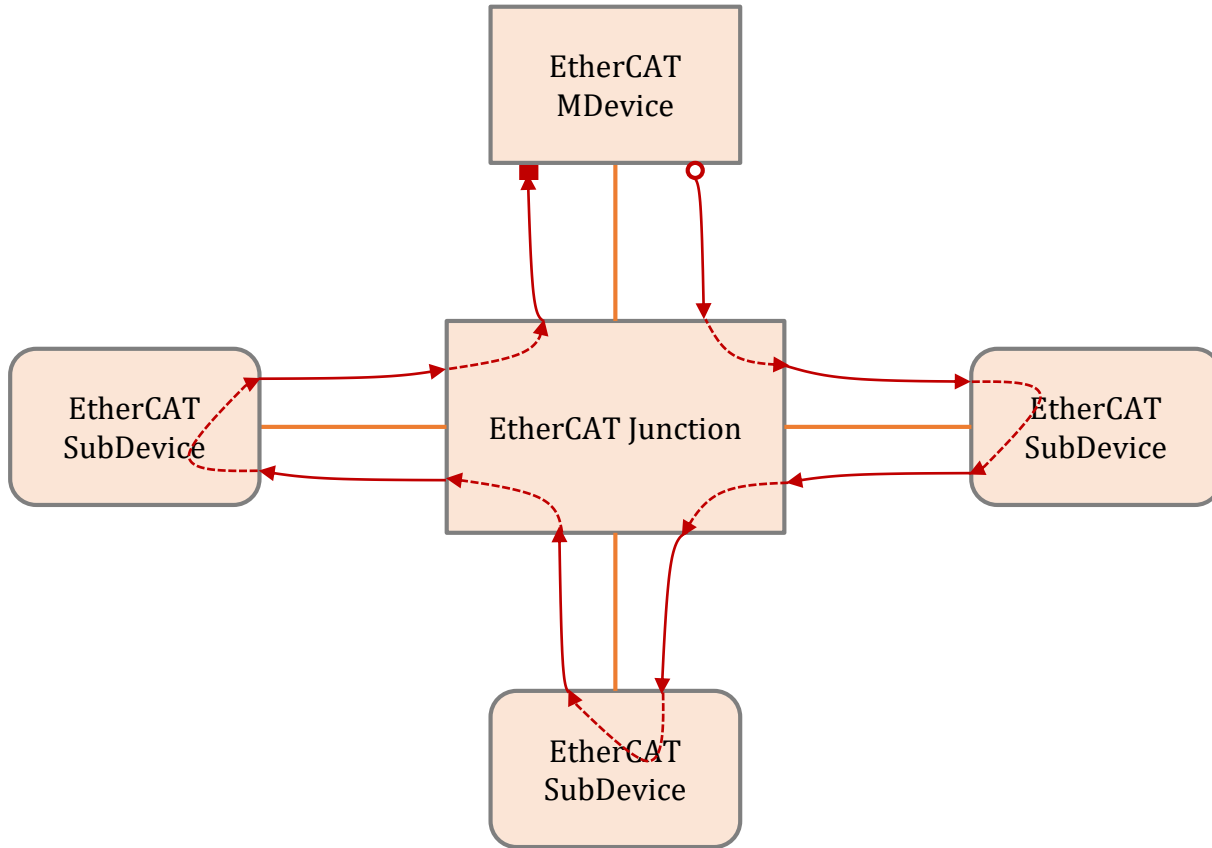

- EtherCAT Junction operates something like a switch
- Forwarding port is statically determined based on ingress port alone
 - ❑ Frames are cut-through forwarded to next port
- EtherCAT Junction is not a bridge

The EtherCAT Junction, as a reference, there are requirements that would request 802.1 Bridges to serve as both an EtherCAT Junction and an Ethernet Bridge.

EtherCAT Open Mode & Direct Mode

- The previous slides indicate EtherCAT direct mode. In the direct mode, the EtherCAT MDevice and the SubDevices are connected one by one, and the frames are forwarded in a logical ring, and the MAC address fields of the EtherCAT frames are not checked (the SA is the EtherCAT MDevice address, and the DA is the broadcast address).
- Using the EtherCAT open mode, one or several EtherCAT segments and corresponding EtherCAT MDevices are connected via Ethernet Bridge. Each segment can be addressed using a “Segment Address SubDevice” (the head station of the segment).
 - ❑ The EtherCAT MDevice sends the EtherCAT frame, and the DA is the MAC address of the Segment Address SubDevice.
 - ❑ The Ethernet Bridge forwards the EtherCAT frame to Segment Address SubDevice.
 - ❑ This Segment Address SubDevice replaces the DA with the SA (address of MDevice) and replaces the SA with its own MAC address.
 - ❑ The EtherCAT frame loops as the rule of EtherCAT in the segment network.
 - ❑ Finally, the EtherCAT frame is forwarded to MDevice by the Ethernet Bridge.
 - ❑ Note that, the EtherCAT MDevice just communicates with one segment only, that is, as the figure right, the EtherCAT MDevice 1 communicates with EtherCAT segment 1 only via orange link, and the EtherCAT MDevice 2 communicates with EtherCAT segment 2 only via light red link.

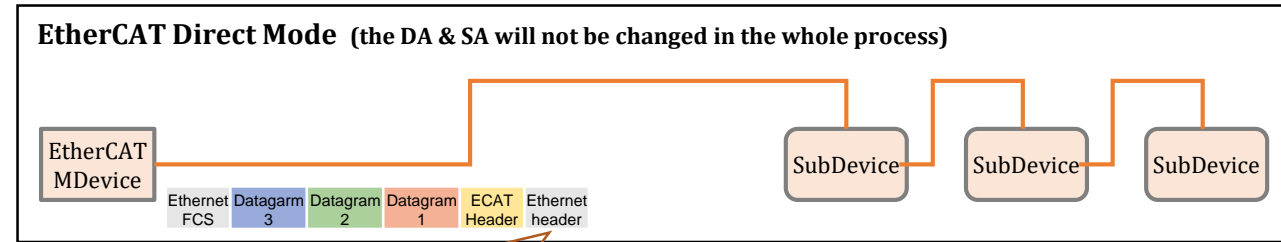

DA = Broadcast address
SA = EtherCAT MDevice MAC address

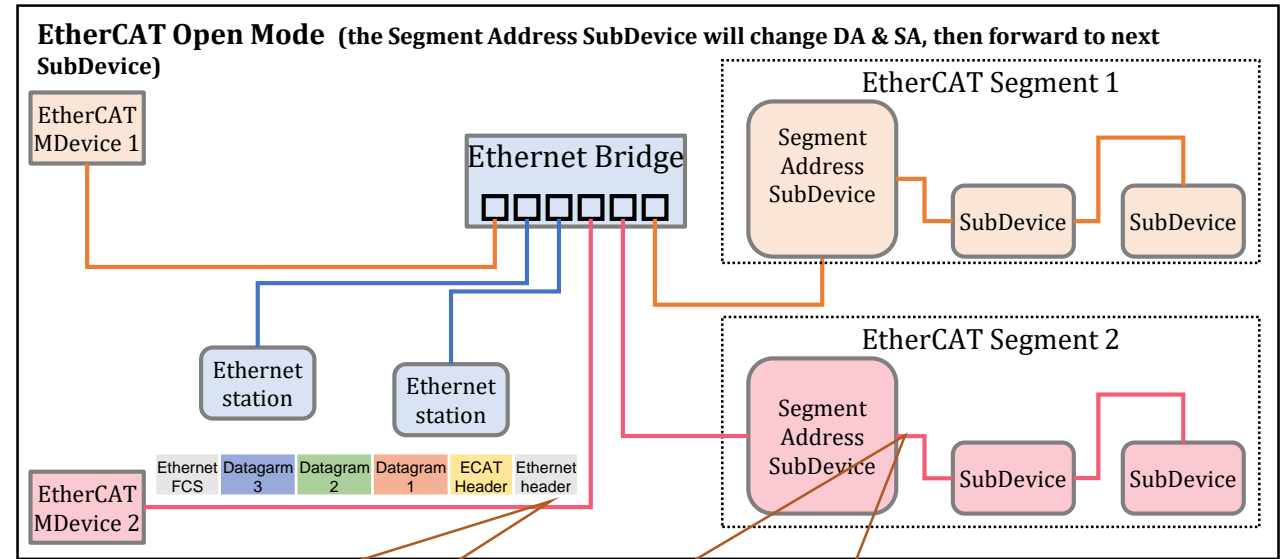

DA = Segment Address SubDevice MAC address
SA = EtherCAT MDevice MAC address

Segment Address SubDevice change the DA & SA MAC
DA = EtherCAT MDevice MAC address
SA = Segment Address SubDevice MAC address

EtherCAT MDevice with Multiple MDevice Instances in Open Mode

- In actual EtherCAT network environment, the EtherCAT MDevice might contain several MDevice instances as the figure right side, and each EtherCAT MDevice instance communicates with a segment respectively.
 - ❑ The MDevice instance 1 communicates with segment 1 via orange link with MAC address 1.
 - ❑ The MDevice instance 2 communicates with segment 2 via light red link with MAC address 2.
 - ❑ The EtherCAT MDevice connects the Ethernet Bridge with one link with two colors (orange and light red), it means both of the MDevice instance 1 and MDevice instance 2 send and receive the EtherCAT frames via this link with MAC of its own.
 - ❑ And the MAC addresses of EtherCAT MDevice instances are administered locally with mechanism to avoid MAC address duplication.
- From the network view, this scenario as figure right side, it's equivalent as the previous slide.
- And this slides just analyze the EtherCAT MDevice with only one MDevice instance.

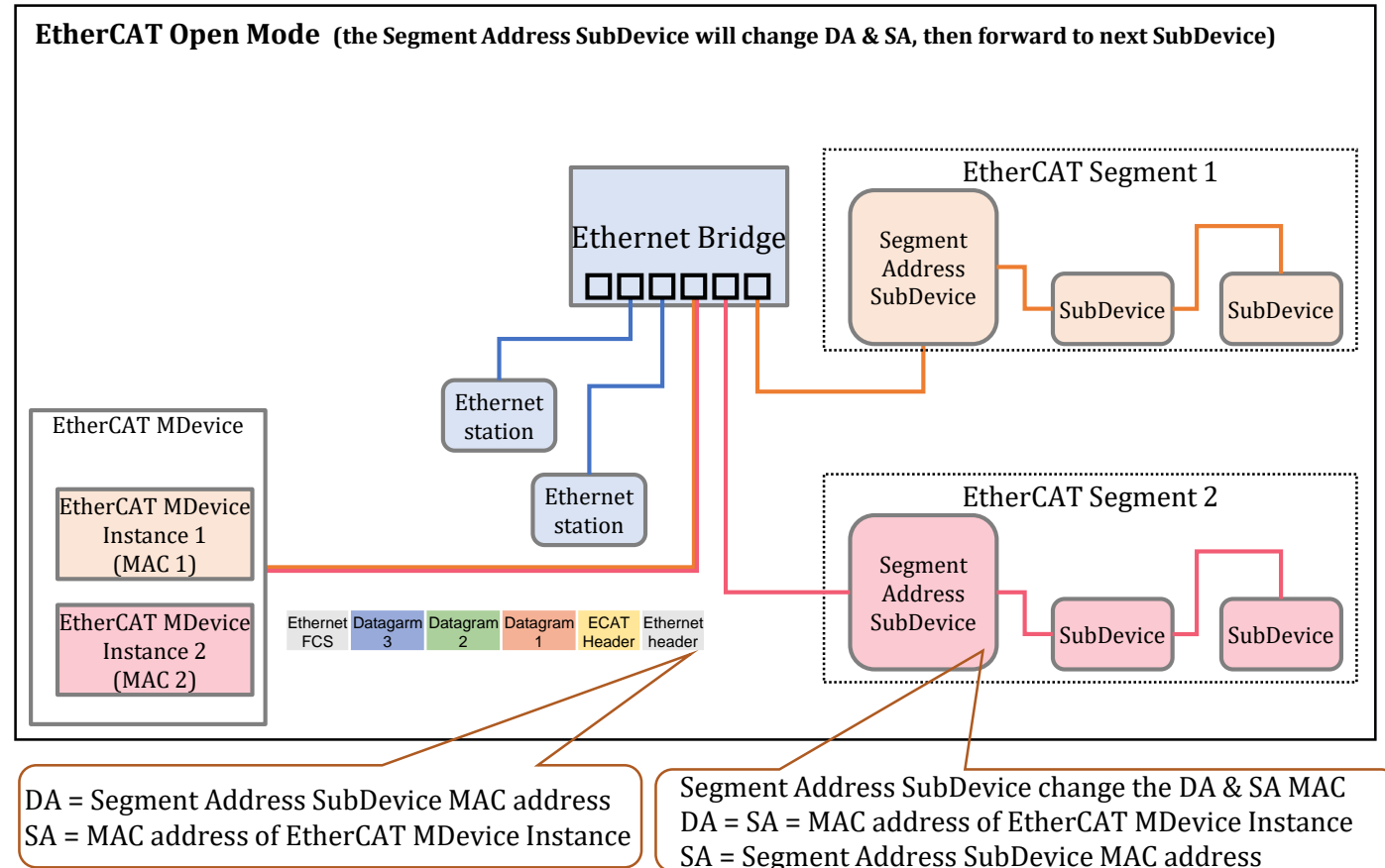

Contents

1. Fundamental introduction of EtherCAT
2. Summary requirements according to industrial scenarios
3. Potential benefits
4. Summary of initial analysis
5. Impact & optimization of evolving technologies
6. Possible recommendation to initiate a work item

Production Lines Request 802.1 Bridges to Support to Expand New EtherCAT SubDevices

- The two production lines are built based on EtherCAT devices in the factory, and the MDevices and SubDevices are connected by EtherCAT Junctions.
- The production lines request to expand new devices including some new SubDevices and some new Junctions, and the production lines request the network KPI: cycle time 4ms, jitter < 10%.
- Near the expansion spot, there are some Ethernet Stations and 802.1 Bridges.
- Considering the space and cost, the factory request 802.1 Bridges to support to forward EtherCAT frames and Ethernet frames simultaneously, that is no need to deploy new EtherCAT Junctions.

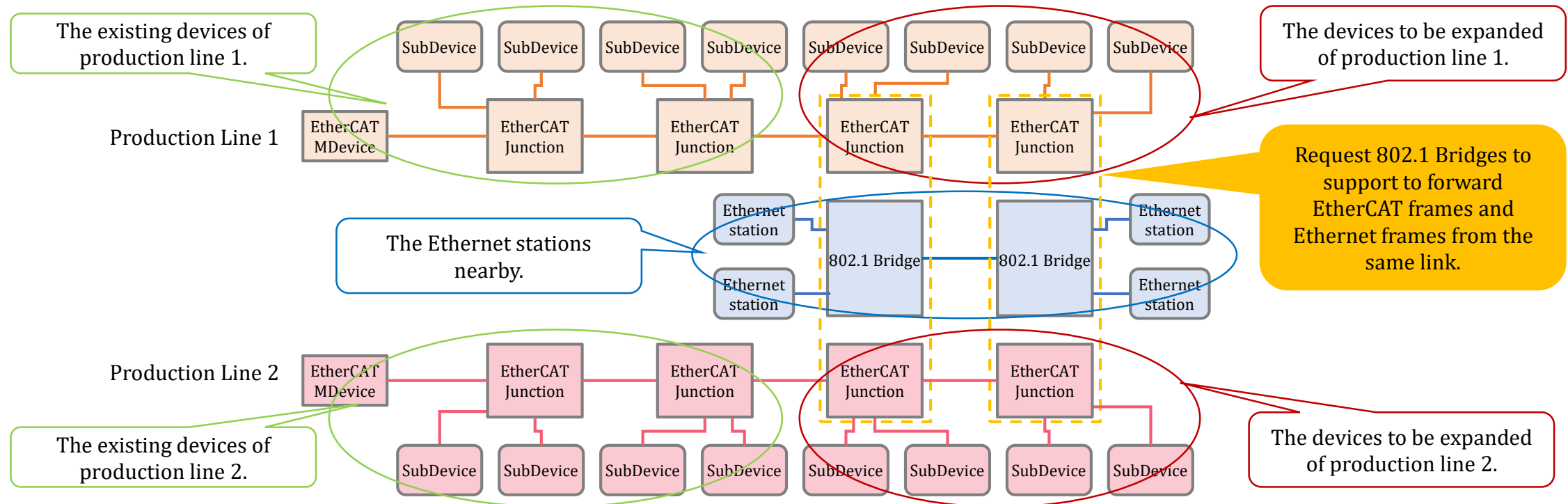

Use Case for 802.1 Bridges to Mix-Transfer Different Kind of Frames

- The existing production lines built based on EtherCAT might be Open Mode as the figure below, and request to expand some new SubDevices.
- The new expanded EtherCAT SubDevices, the existing EtherCAT devices and some other Ethernet stations are connected by Ethernet network of 802.1 Bridges.
- No matter the Open Mode or Direct Mode, there will be different kind of frames to be mix-transferred in the Ethernet network of 802.1 Bridges, and frame identification and QoS assurance should be studied.

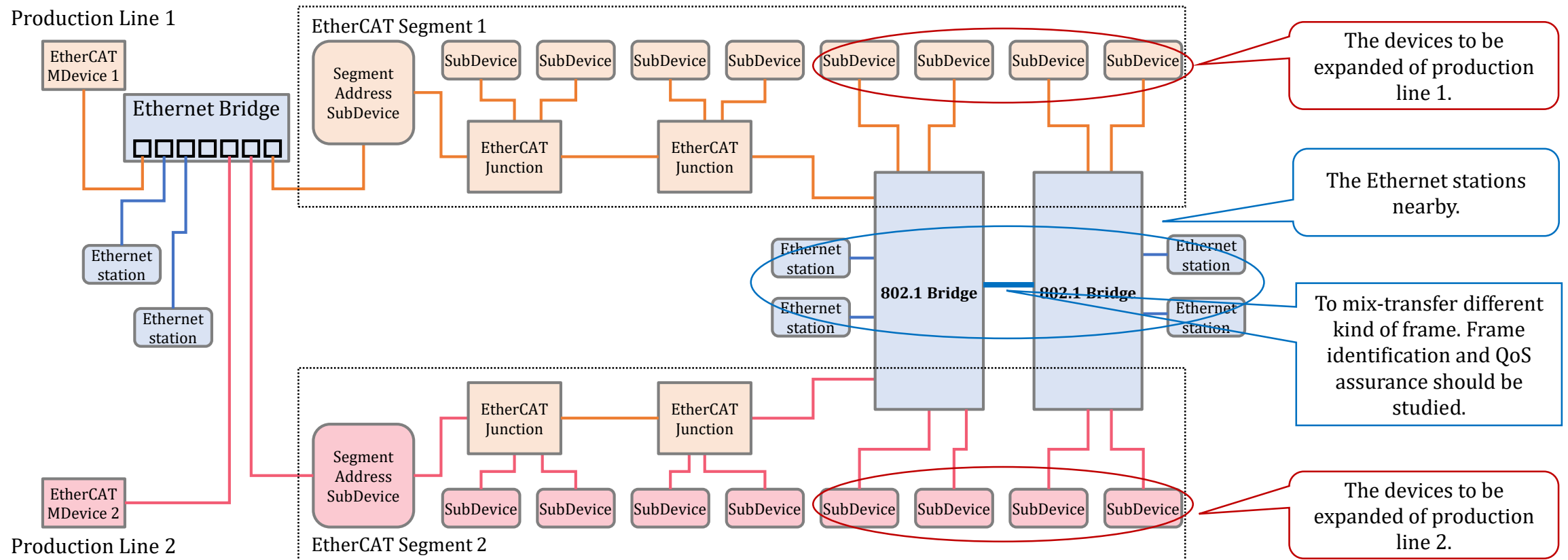

Contents

1. Fundamental introduction of EtherCAT
2. Summary requirements according to industrial scenarios
3. Potential benefits
4. Summary of initial analysis
5. Impact & optimization of evolving technologies
6. Possible recommendation to initiate a work item

Compare of the Use Case and the EtherCAT Open Mode

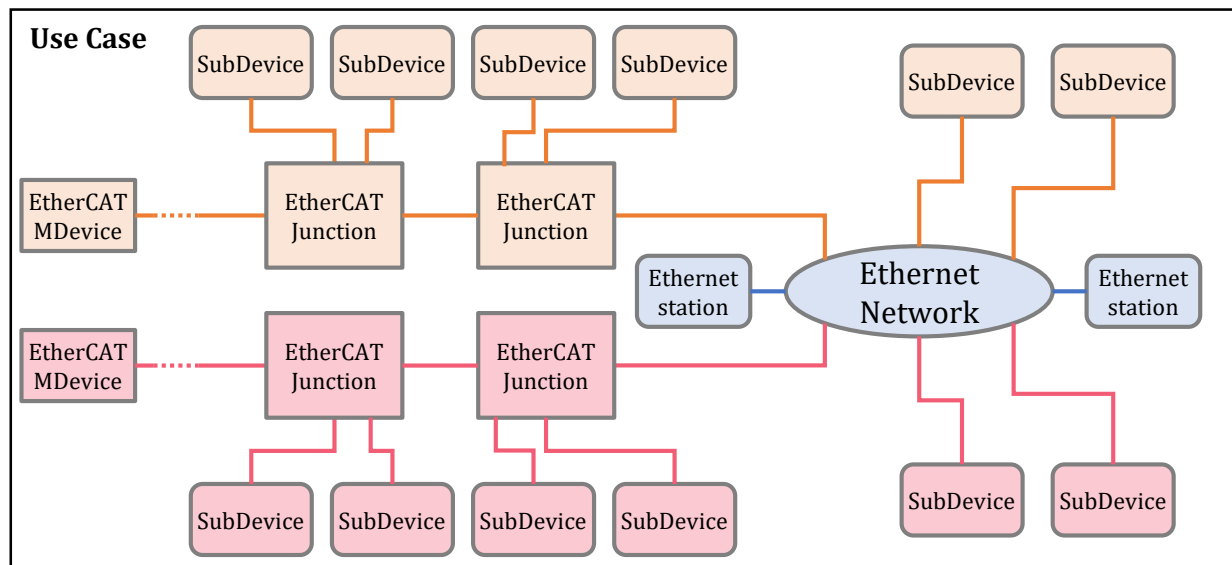
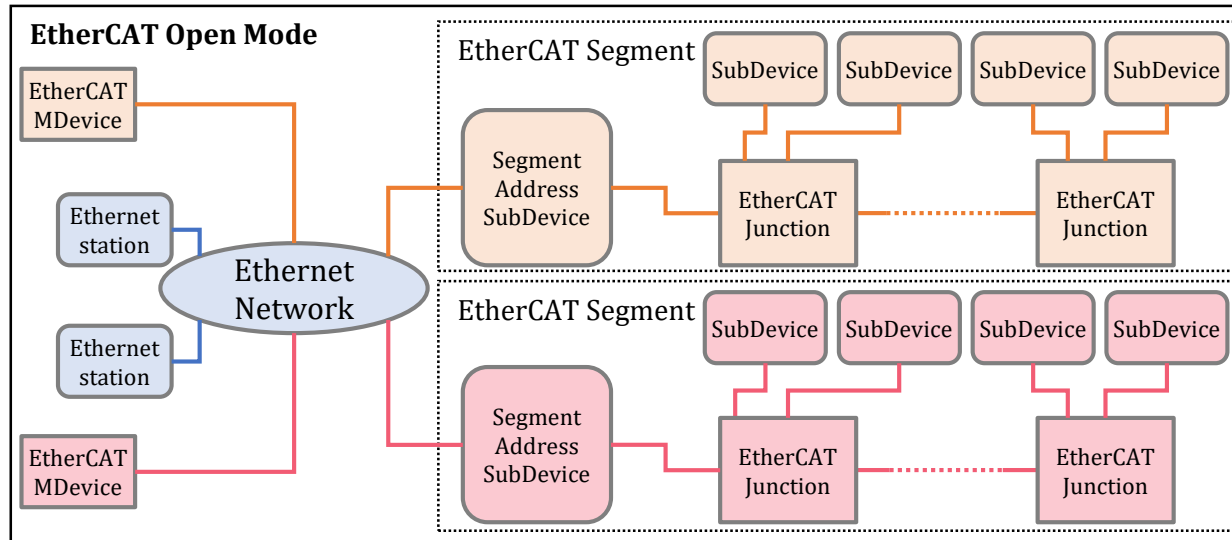

➤ The EtherCAT Open Mode:

- ❑ The Ethernet network connects the EtherCAT MDevices and EtherCAT segments.
- ❑ The Ethernet Bridges just forward the EtherCAT frames according to the MAC address forwarding mode.
- ❑ Even in Open Mode, the EtherCAT segment still is a separated sub-network with group of SubDevices.

➤ The Use Case of production line expansion:

- ❑ The Ethernet network is deployed into the separated sub-network, and connects the EtherCAT SubDevices.
- ❑ And the Use Case tries making the separated sub-network to be involved into the Ethernet network and to more open.
- ❑ The Ethernet Bridges not only supports to forward the Ethernet frames according to the MAC address forwarding mode, but also support to forward EtherCAT frames according to EtherCAT topological forwarding mode.

➤ Common points:

- ❑ Both of them should assure the QoS for EtherCAT frames via some deterministic and high reliable capabilities, and simplify the stream orchestration.

- It's valuable to study these aspects of the use case, and might be referential value for EtherCAT open mode.

Potential Benefits

➤ From the technology view:

- ❑ As the compare of the previous slide, the Ethernet network connecting EtherCAT SubDevices has to assure the QoS of EtherCAT frames, and the related technology evolution and optimization might be valuable to EtherCAT Open Mode.
- ❑ And it might be beneficial for evolution and optimization of 802.1 Bridges toward to be more agile and versatile to support the industrial field scenarios better.
- ❑ Moreover, the Ethernet network deployed into EtherCAT separated sub-network, it makes the EtherCAT separated sub-network to be more open and to be helpful for possible innovation.

➤ From the factory view:

- ❑ The Bridges of Ethernet network connect the existing EtherCAT devices, new extended EtherCAT SubDevices and some other existing Ethernet stations, if the whole solution is feasible, it could save cost for the production lines.
- ❑ Also, it could take full advantage of the existing space of the current workshop to layout the devices reasonably with a higher integrated level.

Contents

1. Fundamental introduction of EtherCAT
2. Summary requirements according to industrial scenarios
3. Potential benefits
4. Summary of initial analysis
 - 3.1 Initial analysis of basic forwarding functionalities
 - 3.2 Initial analysis of QoS assurance
5. Impact & optimization of evolving technologies
6. Possible recommendation to initiate a work item

Initial Solution for the Use Case of EtherCAT Production Line Expansion

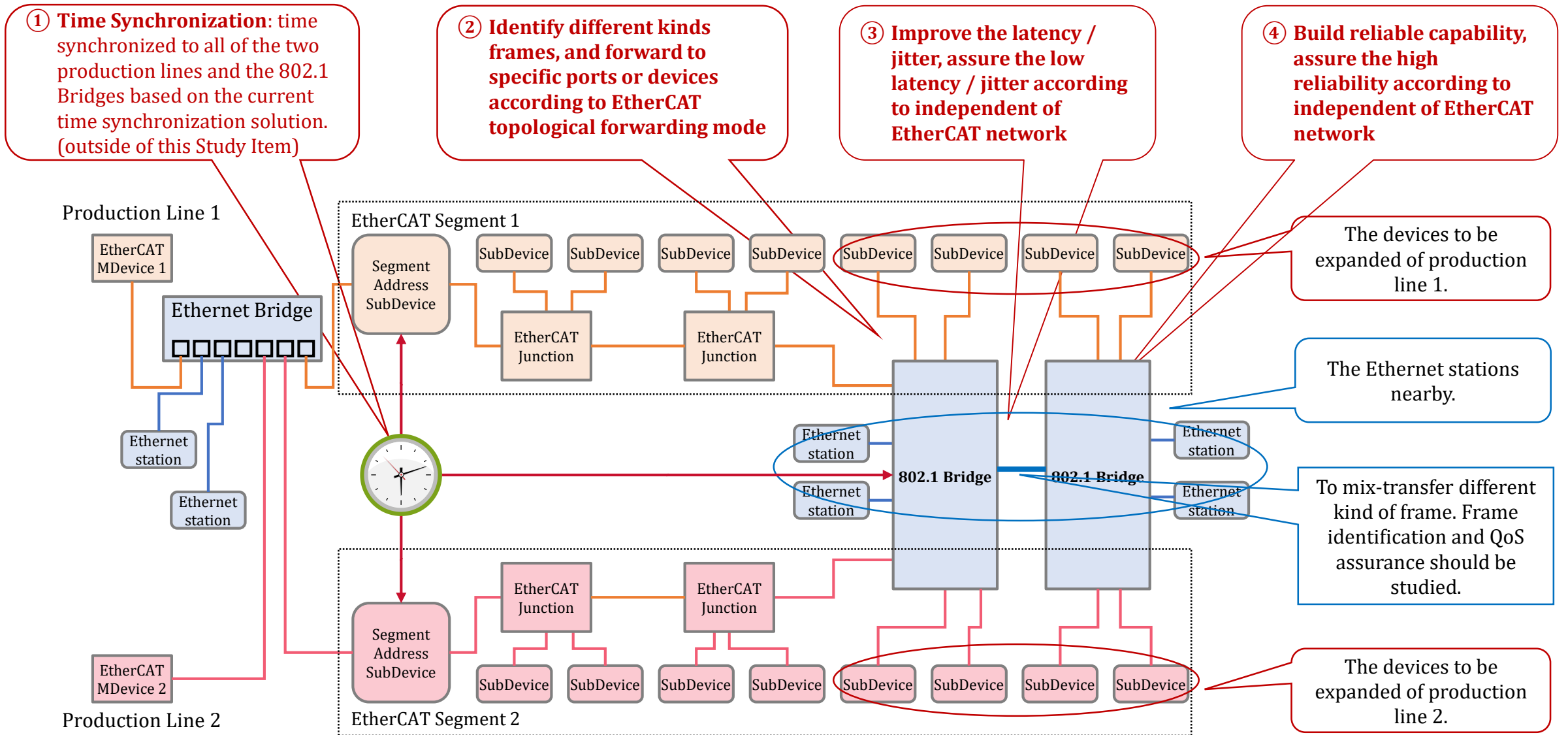

Identify Different Kinds Frames in EtherCAT Open Mode

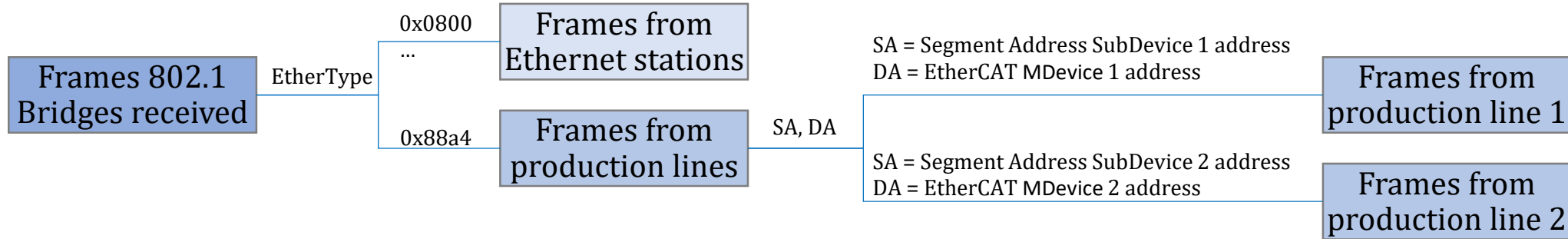

- All the EtherCAT SubDevices of the segment will not change the destination MAC address of the EtherCAT frame, and the EtherCAT frames will be forwarded to next specific SubDevice other than forwarded according to the destination MAC address.
- That is a new request for the 802.1 Bridges to forward the EtherCAT frames to specific port as EtherCAT topological forwarding mode.

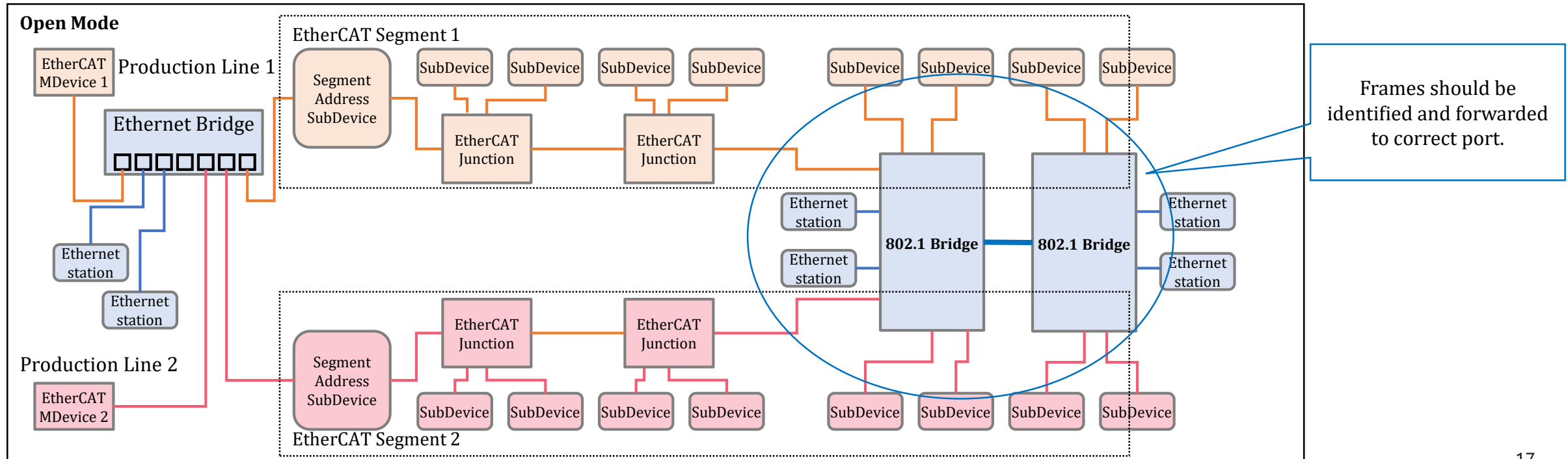

Identify Different Kinds Frames in EtherCAT Direct Mode

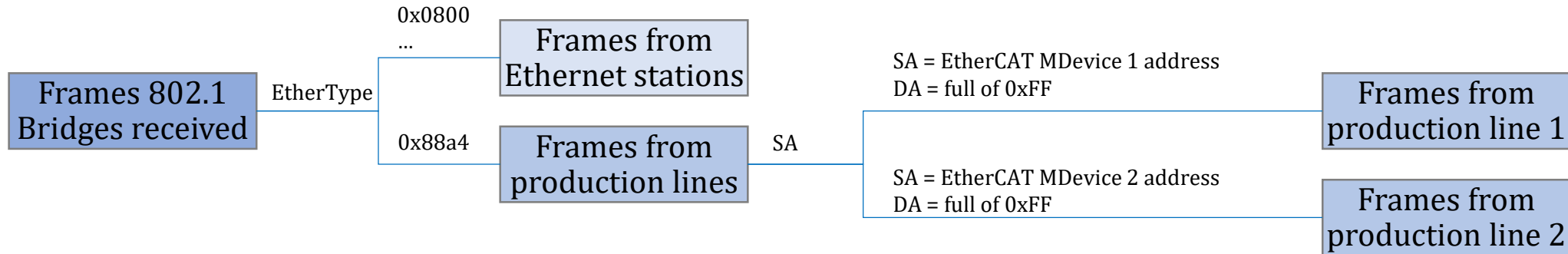

- Even the destination address is the broadcast address, the 802.1 Bridges have to forward the EtherCAT frames according to EtherCAT topological forwarding mode other than the Ethernet address forwarding mode.
- That is a new request for the 802.1 Bridges to forward the EtherCAT frames to specific egress port other than broadcasting to all ports.

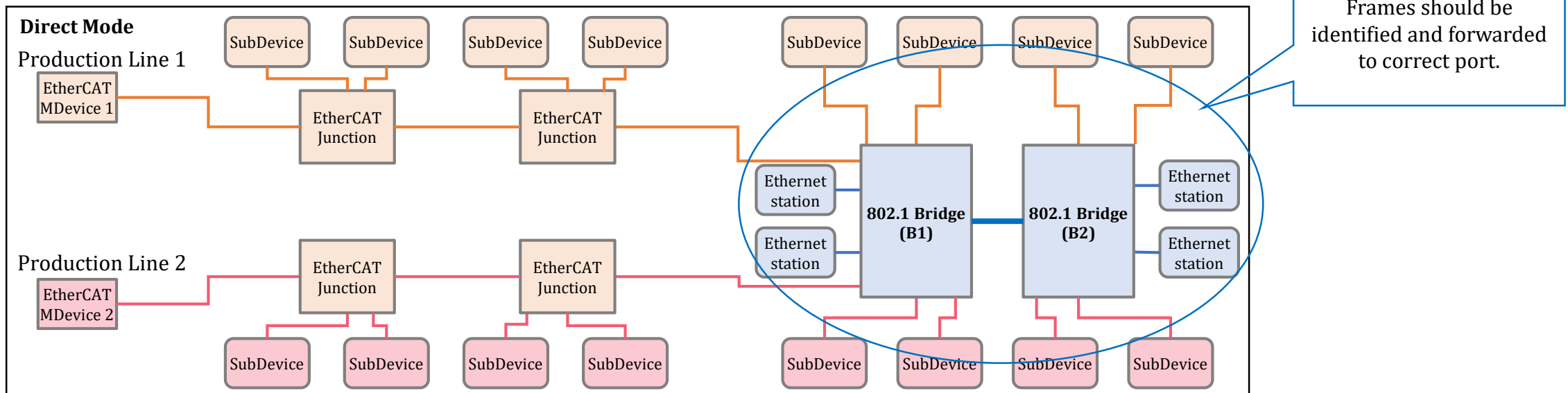

Forward the EtherCAT Frame to Correct Port

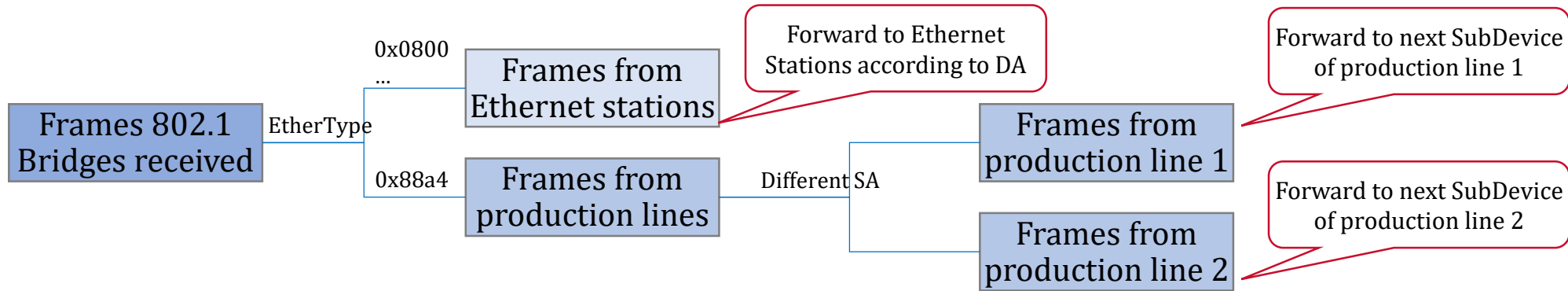

- No matter the Open Mode or Direct Mode, the frames could be identified by EtherType value and MAC address.
- The frames from production lines should be forwarded to next specific SubDevice of the production line respectively, other than forwarded according to the destination MAC address.
- The frames from Ethernet stations should be forwarded according to the destination MAC address.

Identify the Next EtherCAT SubDevice of the Current Production Line in EtherCAT Open Mode

- Set 3 VLANs for 802.1 bridges B1 & B2
 - ❑ Set the ports connecting production line 1 devices into VLAN 1 as access type
 - ❑ Set the ports connecting production line 2 devices into VLAN 2 as access type
 - ❑ Set the ports connecting Ethernet stations into VLAN 3 as access type
 - ❑ Set the ports inter-connecting the 802.1 Bridges into VLAN 1 / 2 / 3 as trunk type
- The frames received from the port connecting to production line devices will be forwarded to next port according to the table right side.

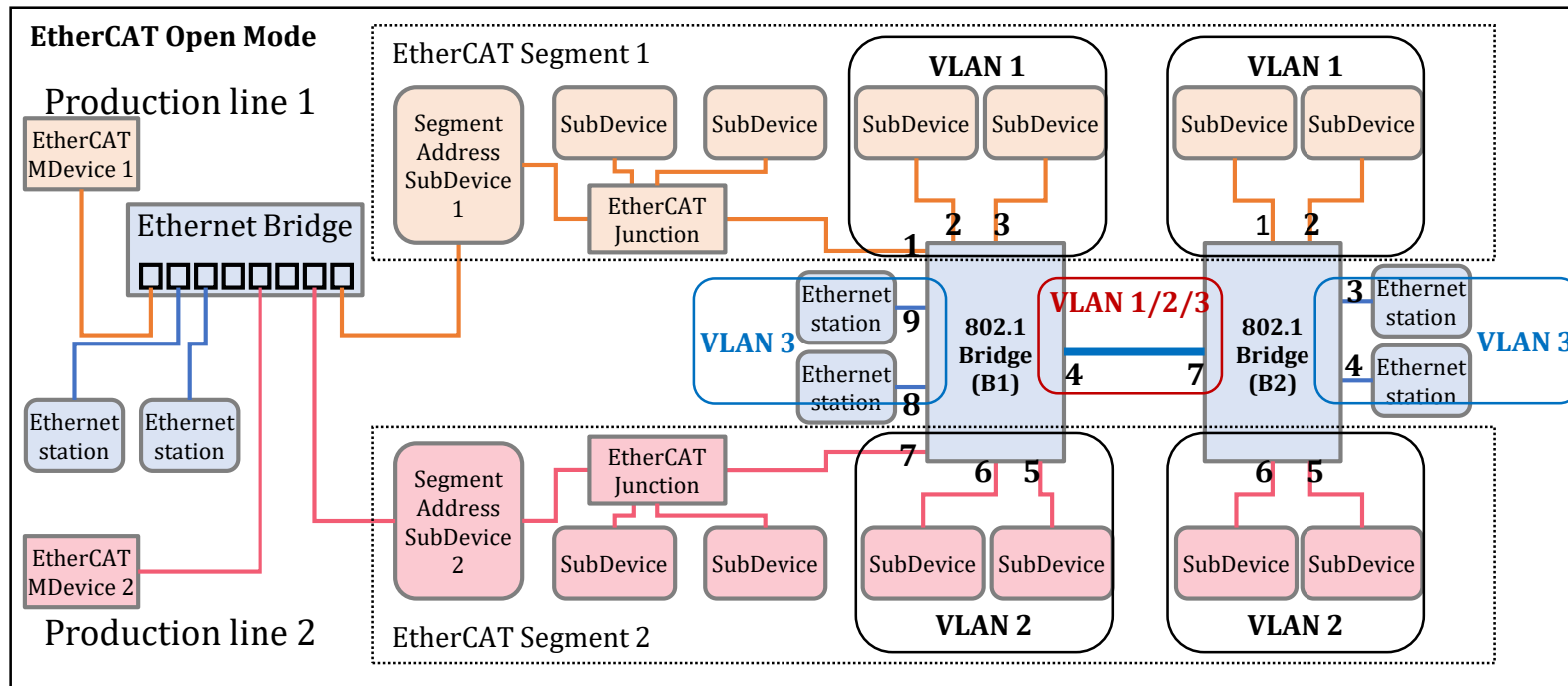

Bridge	Frames Received from	Frames Tagged VLAN	Frames Forwarded to Port
B1	Port 1	VLAN1	Port 2
	Port 2	VLAN1	Port 3
	Port 3	VLAN1	Port 4
	Port 4	VLAN1	Port 1
	Port 7	VLAN2	Port 6
	Port 6	VLAN2	Port 5
	Port 5	VLAN2	Port 4
	Port 4	VLAN2	Port 7
	Port 4	VLAN3	According to DA
B2	Port 7	VLAN1	Port 1
	Port 1	VLAN1	Port 2
	Port 2	VLAN1	Port 7
	Port 7	VLAN2	Port 6
	Port 6	VLAN2	Port 5
	Port 5	VLAN2	Port 7
	Port 7	VLAN3	According to DA
	Port 3	VLAN3	According to DA
	Port 4	VLAN3	According to DA

The table background color represents the frame type corresponding to the figure left.

The Affecting of Ethernet over EtherCAT

- **Ethernet over EtherCAT (EoE)** transparently tunnels standard Ethernet communication via EtherCAT. Tunneling allows the EtherCAT devices to support Ethernet communication without affecting the real-time communication between the EtherCAT MDevice and EtherCAT SubDevices.
- EoE could be typically used for devices with TCP/IP stack, such as a web server, or for infrastructure devices such as switch ports, to which peripheral devices can be connected.
- The EtherCAT MDevice and specific EtherCAT SubDevices operate like a “virtual” layer 2 Ethernet switch whose ports are distributed in the field. The EtherCAT based field network is the backbone of this switch.
- As the figure below, the Ethernet station A communicates with Ethernet station B via EoE, the dash blue line illustrates the communication link routine. The EtherCAT SubDevice X in segment 1 should have the functionality to connect to the port 8 of Bridge 2 via its Ethernet port, and the port 8 will be set into VLAN 3 as access type.

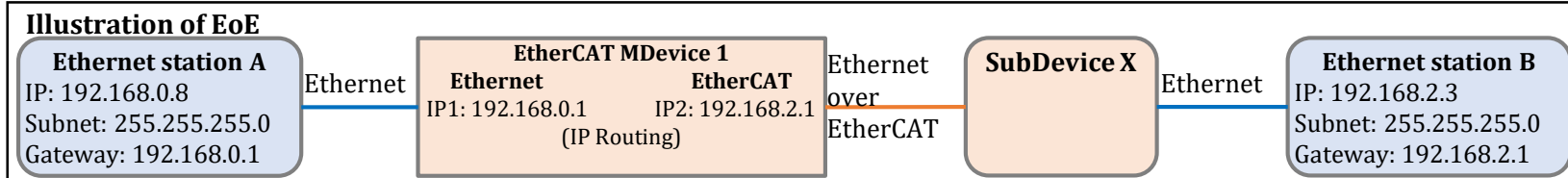
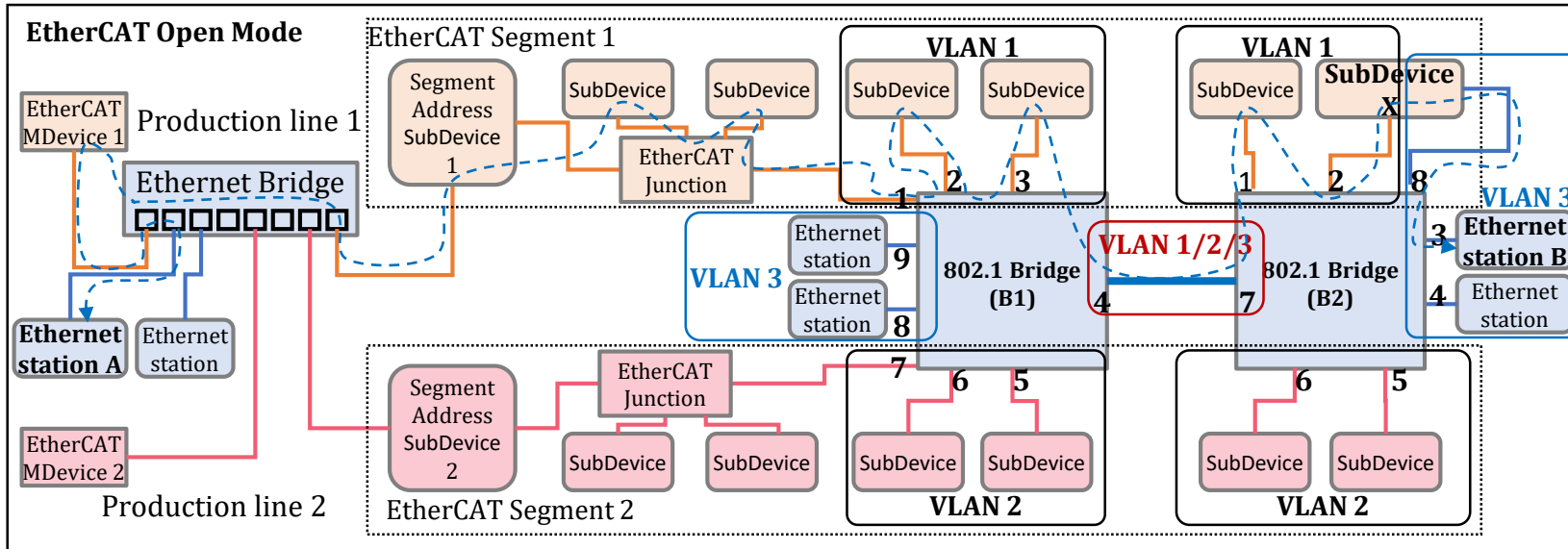

Bridge	Frames Received from	Frames Tagged VLAN	Frames Forwarded to Port
B1	Port 1	VLAN1	Port 2
	Port 2	VLAN1	Port 3
	Port 3	VLAN1	Port 4
	Port 4	VLAN1	Port 1
	Port 7	VLAN2	Port 6
	Port 6	VLAN2	Port 5
	Port 5	VLAN2	Port 4
	Port 4	VLAN2	Port 7
	Port 8	VLAN3	According to DA
B2	Port 7	VLAN1	Port 1
	Port 1	VLAN1	Port 2
	Port 2	VLAN1	Port 7
	Port 7	VLAN2	Port 6
	Port 6	VLAN2	Port 5
	Port 5	VLAN2	Port 7
	Port 7	VLAN3	According to DA
	Port 8	VLAN3	
	Port 3	VLAN3	
Port 4	VLAN3		

Identify the next EtherCAT SubDevice of the current production line in EtherCAT Direct Mode

- Set 3 VLANs for 802.1 bridges B1 & B2
 - ❑ Set the ports connecting production line 1 devices into VLAN 1 as access type
 - ❑ Set the ports connecting production line 2 devices into VLAN 2 as access type
 - ❑ Set the ports connecting Ethernet stations into VLAN 3 as access type
 - ❑ Set the ports inter-connecting the 802.1 Bridges into VLAN 1 / 2 / 3 as trunk type
- The frames received from the port connecting to production line devices will be forwarded to next port according to the table right side.

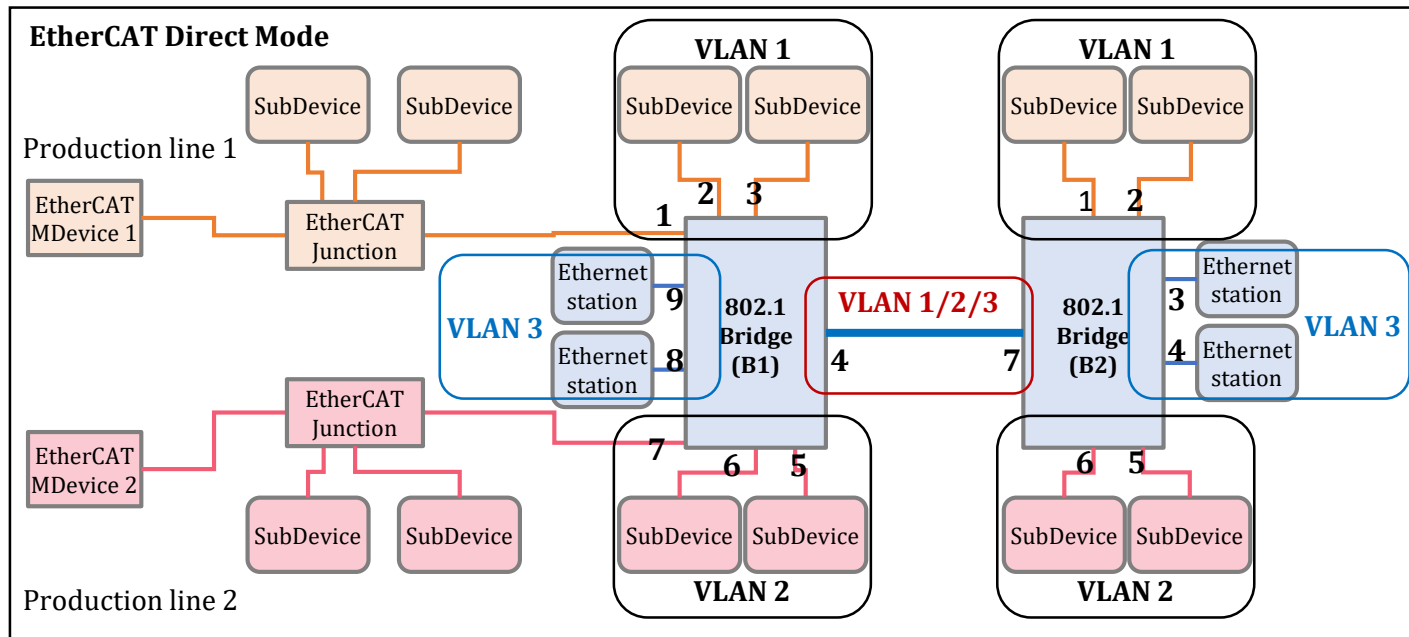

Bridge	Frames Received from	Frames Tagged VLAN	Frames Forwarded to Port
B1	Port 1	VLAN1	Port 2
	Port 2	VLAN1	Port 3
	Port 3	VLAN1	Port 4
	Port 4	VLAN1	Port 1
	Port 7	VLAN2	Port 6
	Port 6	VLAN2	Port 5
	Port 5	VLAN2	Port 4
	Port 4	VLAN2	Port 7
	Port 4	VLAN3	According to DA
Port 8	VLAN3		
Port 9	VLAN3		
B2	Port 7	VLAN1	Port 1
	Port 1	VLAN1	Port 2
	Port 2	VLAN1	Port 7
	Port 7	VLAN2	Port 6
	Port 6	VLAN2	Port 5
	Port 5	VLAN2	Port 7
	Port 7	VLAN3	According to DA
	Port 3	VLAN3	
	Port 4	VLAN3	

The table background color represents the frame type corresponding to the figure left.

Summary of Initial Analysis of Basic Forwarding Functionality

- As the forwarding rule analyzed in the previous slides, the basic functionality of forwarding the EtherCAT frames by 802.1 Bridges is feasible.
- Also, no matter the Direct Mode or Open Mode, the EtherCAT frames could be forwarded to the correct port and correct SubDevices according to the same forwarding rule.
- Besides the basic forwarding functionality, it's necessary to study the impact of QoS, such as low latency, low jitter, high reliability which are as important as the basic forwarding functionality.

Contents

1. Fundamental introduction of EtherCAT
2. Summary requirements according to industrial scenarios
3. Potential benefits
4. Summary of initial analysis
 - 3.1 Initial analysis of basic forwarding functionalities
 - 3.2 Initial analysis of QoS assurance
5. Impact & optimization of evolving technologies
6. Possible recommendation to initiate a work item

Mix-transfer Latency is the Key Part to Affect the Determinism of EtherCAT frames Forwarded on 802.1 Bridges

- Compared with the independent EtherCAT network, the main latency & jitter of the network includes 3 types as below .
- The 3rd category of latency (mix-transfer latency) is the key point to forward EtherCAT frames on 802.1 Bridges.

1. The type of latency related with EtherCAT devices & cables

- ✓ The EtherCAT MDevice latency and corresponding SubDevices / cable latency.
- ✓ This part of latency & jitter is the same as the EtherCAT independent network.

2. The 802.1 Bridges forward the EtherCAT frames to next EtherCAT SubDevice. (CTF latency)

- ✓ This type of latency is used to forward the EtherCAT frames between the Bridge ports which are connecting to EtherCAT SubDevices directly.
- ✓ These Bridge ports transmission rate are the same, also equals to port transmission rate of EtherCAT SubDevices.
- ✓ So, the **cut-through forwarding** could be used to minimize the latency and jitter.

3. The 802.1 Bridge forward the EtherCAT frames to the next 802.1 Bridge. (mix-transfer latency)

- ✓ This type of latency is used to forward the EtherCAT frame between the port (connecting to EtherCAT SubDevice) and another port (connecting to next 802.1 Bridge).
- ✓ The transmission rate of the two ports are different, store and forward mode should be mandatory.
- ✓ And, the streams from different EtherCAT MDevice will be mix-transferred in the inter-link, so it's necessary to orchestrate to achieve low latency & low jitter.
- ✓ Besides, **simplify the orchestration** should be considered.

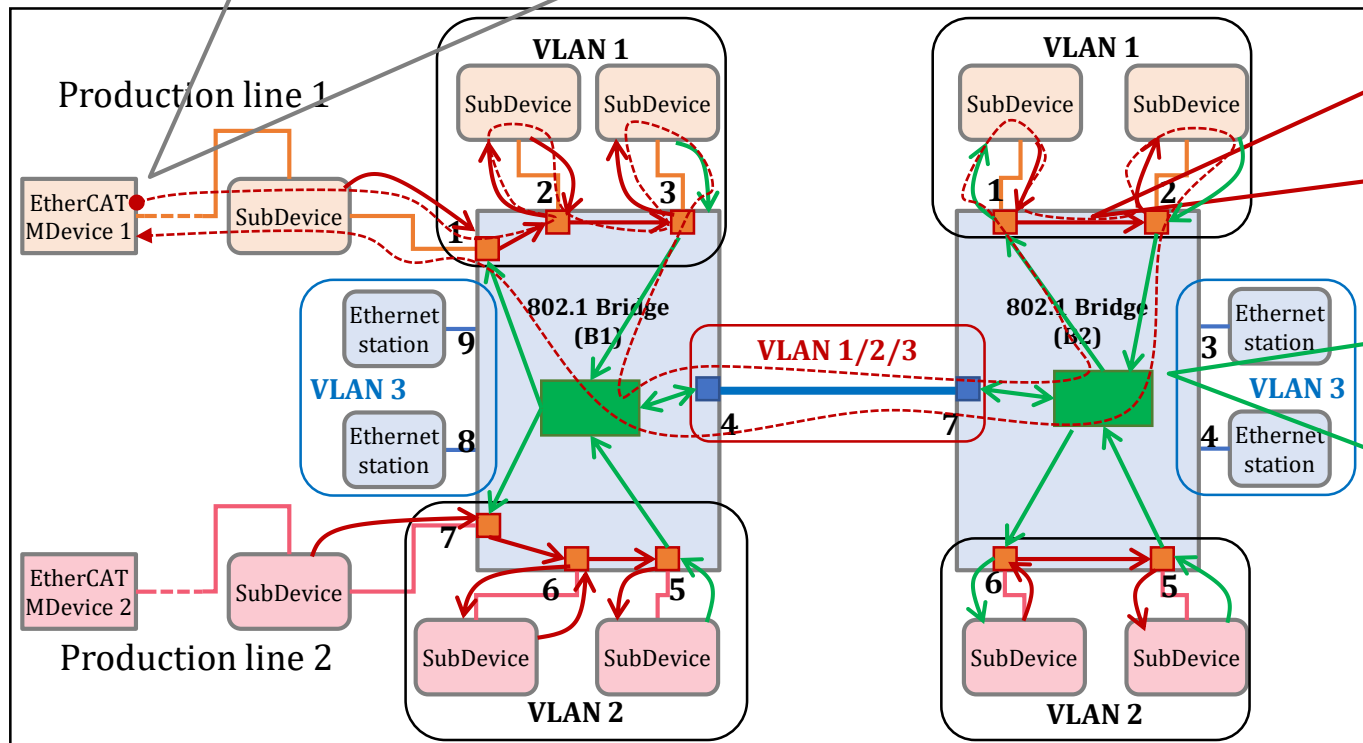

- ❑ **CTF (cut through forwarding) Latency:** The red lines indicate that the EtherCAT frames are cut-through forwarded between the ports connecting to SubDevices directly.
- ❑ **MT (mix-transfer) Latency:** The green lines / blocks indicate that the EtherCAT frames are stored and forwarded between the ports belonging to different VLAN.
- ✓ The EtherCAT frames from different production lines have to be orchestrated to achieve low latency and low jitter.

To Identify the EtherCAT Streams via Talker, Listener & Stream Direction

- According to Talker & Listener concept of 802.1Q, Talker is the source or producer of a stream, and Listener is the destination, receiver, or consumer of a stream. Stream is a unidirectional flow of data (e.g., audio and/or video) from a Talker to one or more Listeners.
 - ❑ In this scenario, the EtherCAT MDevice should be the Talker originating the EtherCAT frames through Bridges to the last EtherCAT SubDevice as the listener, then the last EtherCAT SubDevice loops back the EtherCAT frames to the EtherCAT MDevice through the Bridges.
 - ❑ Because of the EtherCAT topological forwarding mode, the MAC addresses of EtherCAT frames are the same while transferring from Talker to Listener or Listener to Talker.
 - ❑ It has to include the stream direction to identify the streams, even the source MAC address and destination MAC address are the same, but the direction is different, they should be different streams.
- And frames of different streams might be processed according to different rules to assure QoS.

Initial Analysis of Mix-transfer Latency of Forwarding EtherCAT Frames

- In this scenario, there are several kinds of frames to be mix-transferred along the inter-connection between 802.1 Bridges.
- Each kind of frame has its own requirement of low latency / jitter.
- So, there will be confliction and network resource competition along the inter-connection between 802.1 Bridges.
- The EtherCAT frames from EtherCAT MDevice 1 and MDevice 2 have to be orchestrated and scheduled to assure the low latency / jitter for all of them, meanwhile, it's better to simplify the stream orchestration.
- The rest of Ethernet frames from Ethernet stations will be forwarded with best efforts.

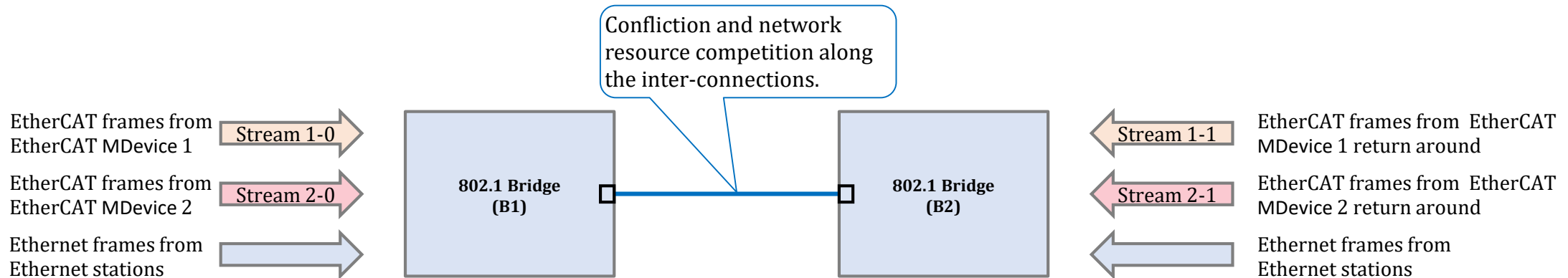

- This is the simple example of Ethernet network to mix-transfer different kind of frame.
- There might be more 802.1 Bridges in actual network environment.

Initial Analysis of High Reliability of the Inter-Connection between the 802.1 Bridges

- According to EtherCAT application cycle requirements, the redundancy recovery time is micro-second level as specified in IEC 61784-2, which is implemented with co-operation of EtherCAT devices via ring topology generally.
- Even 802.1CB could implement the high reliability for the frames, but the frame is replicated, transmitted via two different routine, and double bandwidth is used out.
- In order to make full use of network bandwidth, it might be the possible methodology for Ethernet network of 802.1 Bridges to support the high reliability of micro-second level recovery time based on the physical ring topology as figure below.

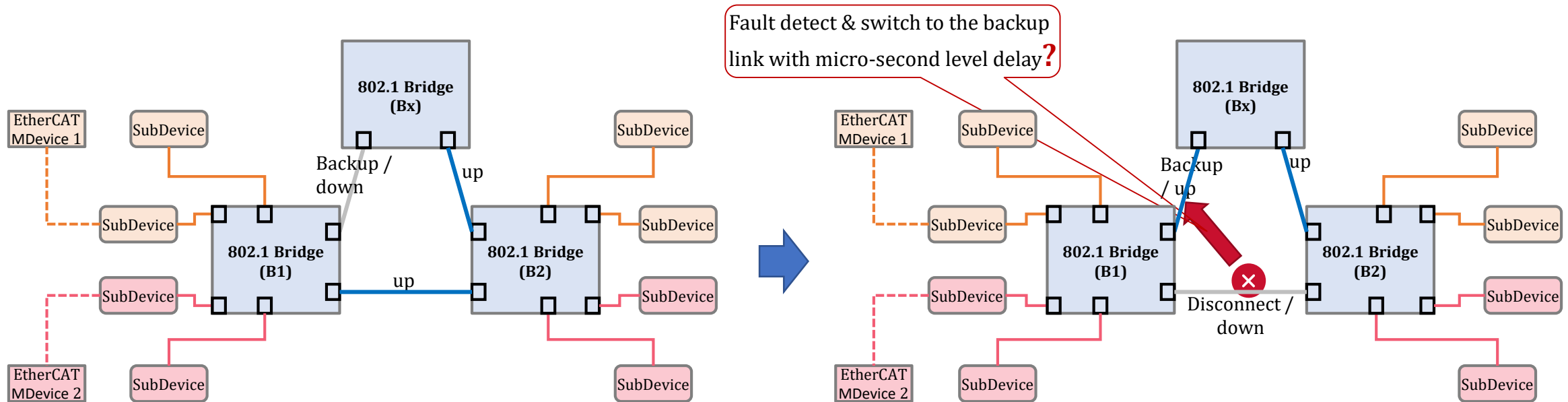

- In actual network environment, the Ethernet network might be deploy as ring network for high reliability.
- This is the simple example of Ethernet network to illustrate the high reliability of network topology.
- The dash line means there might be many SubDevices or other devices between the MDevice and this SubDevice.

Summary of QoS Assurance for EtherCAT Frames

➤ As compared with independent EtherCAT network, this section initially analyzes the technical scenarios of QoS assurance of EtherCAT frames.

1. Mix-transfer latency / jitter

- ✓ The 802.1 Bridges mix-transfer several kinds of frames simultaneously, and the EtherCAT frames from different EtherCAT MDevice request different low latency / jitter, other Ethernet frames could be forwarded with best efforts.
- ✓ Compared to independent EtherCAT network, it causes the confliction and network resources competition along the inter-connection between Bridges.
- ✓ The confliction and network resources competition along the inter-connection between Bridges affect the determinism of EtherCAT frames.
- ✓ It's valuable to study and analyze the technical optimizations to achieve low and bounded latency and to simplify the stream orchestration.

2. High reliability

- ✓ The EtherCAT frames request high reliability of redundancy recovery time as micro-second level as specified in IEC 61784-2.
- ✓ The Ethernet network of 802.1 Bridges connecting the EtherCAT devices could be the ring topology physically, and provide the backup link to forward the EtherCAT frames without frame replication while one link is disconnected.
- ✓ Compared with independent EtherCAT network, the high reliable recovery time of the Ethernet network should satisfy the corresponding requirements of EtherCAT frames.
- ✓ It's valuable to study and analyze the technical optimizations to assure the recovery time of the Ethernet network as micro-second level without frame replication.

Contents

1. Fundamental introduction of EtherCAT
2. Summary requirements according to industrial scenarios
3. Potential benefits
4. Summary of initial analysis
5. Impact & optimization of evolving technologies
6. Possible recommendation to initiate a work item

Impact of Strictly Orchestration based on 802.1Qbv to Achieve Bounded Latency

- Based on the time synchronization to two production lines and the 802.1 bridges, the frames from EtherCAT MDevice 1 / EtherCAT MDevice 2 and the Ethernet stations will be mix-transferred in the inter-link between the 802.1 bridges.
 - ❑ The inter-link bandwidth between the 802.1 Bridges could be evaluated according the EtherCAT frame size and application cycle.
 - ❑ The transfer delay from the EtherCAT MDevice to 802.1 Bridges could be evaluated based on the frame size and bandwidth.
 - ❑ All these parameters and evaluation results will be input as per 802.1Qbv, and orchestrate the streams to get the specific timeline, and distribute the timeline to each bridge.
 - ❑ The timeline contains a list of time point, each time point indicates the Bridge have to receive the frame and send to next Bridge.
 - ❑ Along the end to end routine, each Bridge should receive the EtherCAT frames and send to next Bridge as per the timeline strictly.
 - ❑ According to the figures below, generally, the periods between each adjacent time points are different, it could achieve low latency as low as possible, each EtherCAT frame are received on time and sent out on time.
 - ❑ Based on 802.1Qbv, it's feasible to achieve the determinism of all the EtherCAT frames of MDevice 1 & MDevice 2.

• $C_1 = \text{Cycle of EtherCAT MDevice 1}$, $C_2 = \text{Cycle of EtherCAT MDevice 2}$, $C_1 \geq C_2$

1. $C_1 = C_2$

2. $C_1 = nC_2$ ($n > 1$ is an integer)

3. $C_1 = mC_2$ ($m > 1$ is not an integer)

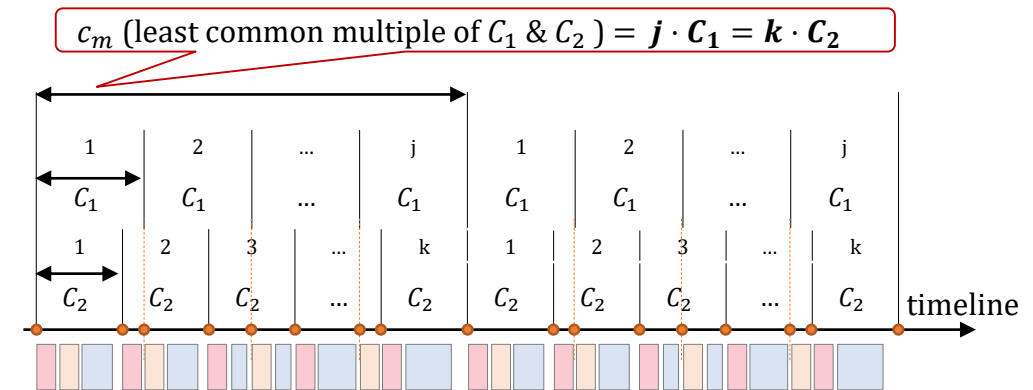
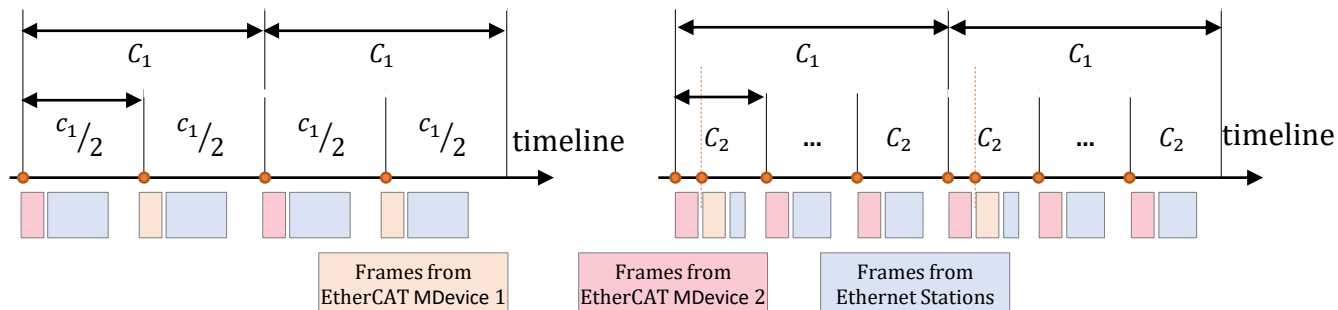

Possible Optimization Directions to Assure Determinism with Simple Orchestration of Stream

➤ The 802.1Qbv strict orchestration including following factors:

- ❑ The periods between the two adjacent time points are **different**.
 - ❑ The action of sending out frames has to be done **as per the timeline** with strict time synchronization, no earlier and no later than the time point.
- It might be uneasy to orchestrate the streams and strict time line while increasing the network scale and stream quantity.

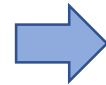
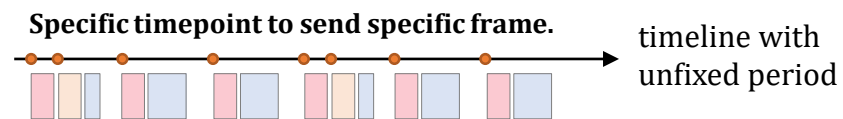

➤ Based on 802.1Qch, the Ethernet Bridges send the frames according to a same rhythm cyclically other than a strict timeline.

- ❑ Each bridge use the **same period** to send the frames cyclically, and the EtherCAT frame is sent out as the cyclic shuttle.
 - ❑ No matter the routine is long or short, the corresponding transmission time of the shuttle along the link is different, but in a Bridge, the departure time of shuttle is **cyclically fixed**, likewise the adjacent Bridge.
 - ❑ That is, the adjacent Bridges build the period mapping relationship, and the end to end transmission latency of frame is anticipated and bounded.
 - ❑ But, the relatively simple orchestration of streams leads to latency increased.
- In order to satisfy the determinism requirement of EtherCAT service of which the frames are mix-transferred on Ethernet network, the following optimization points could be considered:
- ❑ To make full use of the network bandwidth to avoid using big fixed period.
 - ❑ To use the fixed small period to minimize the wait duration for departure time.
 - ❑ To minimize the end to end transmission latency of EtherCAT frames to build the explicit & tight period mapping relationship between the adjacent Bridges.

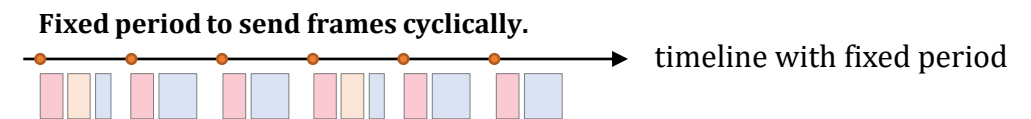

Frames from
Production Line 1

Frames from
Production Line 2

Frames from
Ethernet Stations

Analysis of the Existing High Reliable Capabilities

- The table below list the main reliable capabilities. Regarding the recovery time, most of them are milli-second level except 802.1CB and IEC 62439-3.
- But, 802.1CB and IEC 62439-3 replicate the frame and transmit along two different routine path to achieve high reliability of zero recovery time, that is, twice of network bandwidth is needed.

NO.	Redundancy / Reliable Capability	Topology Supported	Recovery Time Level
1	Rapid Spanning Tree Algorithm and Protocol (802.1w)	Ring, Mesh	Hundreds of milliseconds
2	Medium Redundancy Protocol (IEC 62439-2)	Ring	Dozens - hundreds of milliseconds
3	Distributed Redundancy Protocol (IEC 62439-6)	Ring	Hundreds of milliseconds
4	Spatial Reuse Protocol (RFC 2892)	Ring	Hundreds of milliseconds
5	Cross-network Redundancy Protocol (IEC 62439-4)	Mesh	Hundreds of milliseconds
6	Ethernet Ring Protection Switching (ITU-T G.8032)	Ring	Dozens milliseconds
7	Ethernet Linear Protection Switching (ITU-T G.8031)	Linear	Dozens milliseconds
8	Frame Replication and Elimination for Reliability (802.1CB)	Ring, Mesh	Zero
9	Parallel Redundancy Protocol (IEC 62439-3)	Mesh	Zero

Milli-second level recovery time.

Zero recovery time, but network bandwidth doubled.

Possible Optimization Directions to Achieve the Micro-second Level Recovery Time to Forward EtherCAT Frames via 802.1 Bridges

- As specified in IEC 61784-2, the redundancy recovery time of EtherCAT is micro-second level.
- As we recap the existing high reliable capabilities, most of them are build upon the level 2 or high layer, that might be the reason, the recovery time is milli-second level.
- Based on Ethernet network of 802.1 Bridges, with the aim to achieve micro-second level recovery time without frame replication, the possible optimization directions are provided as following:
 - ❑ To make use of Ethernet network ring topology, detect the link fault and activate the backup link.
 - ❑ To build the network fault detection capability in low layer other than layer 2 or high layer.
 - ❑ To build the network recovery capability in low layer to achieve quick deliver the fault point information and trigger to activate the backup link.
 - ❑ To build the high reliable capability in network level completely to avoid additional co-operation of end device.
 - ❑ To avoid the influence to data frames, it's better for the fault detection and notification frame to use no more than 1% of the network bandwidth.

Summary of Optimization Directions to Assure QoS of EtherCAT Frames

- This section initially analyzes the optimization directions to assure QoS of EtherCAT frame.
 - ▣ Mix-transfer latency / jitter
 - ✓ As analyzed, the 802.1Qbv could satisfy the low latency / jitter, but it's uneasy to implement the streams orchestration while increasing the network scale and stream quantity.
 - ✓ The 802.1Qch could facilitate stream orchestration relatively but it will increase the latency.
 - ✓ In order to combine the simple orchestration and low latency , the following optimization directions could be considered to assure the determinism of EtherCAT frames based on 802.1Qch.
 - To make full use of the network bandwidth to use small fixed period and minimize the wait duration for departure time of EtherCAT frame in each Bridge.
 - To minimize the end to end transmission latency of EtherCAT frames to build the explicit & tight period mapping relationship between the adjacent Bridges.
 - ▣ High reliability
 - ✓ As analyzed the following optimization directions could be considered to achieve the high reliability without frame replication.
 - To build the high reliability on lower layer of Ethernet network (of ring topology) to quickly detect link down and activate the backup link.
 - To avoid influence to end devices, keep compatible to devices and minimize the bandwidth usage of detection frame (no more than 1%).
- For further analysis, it's still need depth studies of scenarios, requirements, technologies, and respective evolutions.

Contents

1. Fundamental introduction of EtherCAT
2. Summary requirements according to industrial scenarios
3. Potential benefits
4. Summary of initial analysis
5. Impact & optimization of evolving technologies
6. Possible recommendation to initiate a work item

Possible Recommendation to Initiate a Work Item

- This Study Item studies the use case of 802.1 Bridges to forward EtherCAT frames and Ethernet frames simultaneously, initially analyzes the technologies, and provides possible technical optimization directions.
- In order to further analyze the requirements, technologies, and respective evolutions, this document recommends Nendica consider to initiate a Work Item to document the followings in full details:
 - ❑ The use case of forwarding EtherCAT frames and Ethernet frame simultaneously via 802.1 Bridges, and corresponding environment factors could be considered.
 - ❑ To analyze the requirement evolution from EtherCAT application and production line level.
 - ❑ The topology of Ethernet network of 802.1 Bridges connecting EtherCAT devices and Ethernet stations, and typical topology of EtherCAT used in factory level might be considered.
 - ❑ The multi-forwarding modes of 802.1 Bridges to forward EtherCAT frames and Ethernet frames.
 - ❑ The related technology evolution and gap analysis, and the requirements and issues of assuring the QoS of EtherCAT frames .
 - ❑ Other aspects to be considered to assure the compatibility and completeness for EtherCAT application and Ethernet network.
 - ❑ Future directions towards enhancements of 802.1 Bridges to co-operate with EtherCAT to assure QoS of EtherCAT frames.
 - ❑ Based on these detail aspects of requirements, challenges and evolutions, to consider the possible standardization recommendations.

Thank you.